



3/4" ATB075C Bolted Bonnet Shut-Off Valve

INTRODUCTION

The advanced design and materials of Hansen extended neck, bolted bonnet, refrigerant shut-off and hand expansion valves make them far superior to commonly available products. The extended neck greatly simplifies insulation, and allows compliance with industry guidelines for insulation thickness. In addition, non-leak seats, stems, and bonnets virtually eliminate the possibility for refrigerant leakage. Anyone who has experienced the failure of a shut-off or hand expansion valve at a crucial time will take care to insist upon these highly reliable valves. Bar handle or yellow seal caps distinguish hand expansion valves from shut-off valves.

MATERIAL SPECIFICATION

Body:	Forged Steel, ASTM A105
Stem:	Stainless Steel
Disc Holder:	Steel
Seat Disc:	PTFE Teflon, Retained
Ball Bearings:	Stainless Steel
Packing Nut:	Corrosion Resistant Coated Steel
Stem Packing:	Graphite Composite Plus Neoprene O-ring
Handwheel:	Zinc-plated Alloy
Bonnet:	Ductile Iron ASTM A536
Seal Cap:	Glass-filled Polymer, Safety Vented

CONNECTION DIMENSIONS

Threaded 1/2" through 1 1/4": US NPT female tapered pipe thread

Socket Welding 1/2" through 1 1/4": US steel pipe

Butt Welding 1/2" through 1 1/4": US steel pipe

Specifications, Applications, Service Instructions & Parts

EXTENDED NECK, BOLTED BONNET, SHUT-OFF & HAND EXPANSION VALVES

1/2" through 1 1/4" Threaded, Socket Weld, and Butt Weld Globe and Angle for Refrigerants

*13 mm through 32 mm

KEY FEATURES

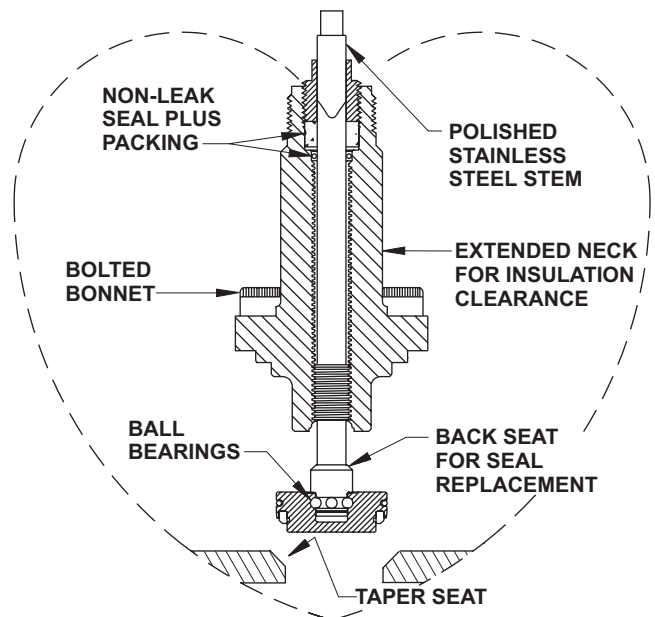

ADDITIONAL FEATURES

- Suitable for ammonia, R22, R134a, and other Hansen approved refrigerants
- Extended bonnet provides greater insulation clearance
- Large bonnet bolts for exceptional strength
- Teflon seat disc (no lead)
- 400 psig (27 bar) safe working pressure
- Temperature range: -60°F to +240°F (-50°C to +115°C)
- Nonasbestos gaskets

APPLICATIONS: SHUT-OFF VALVES

Shut-off valves are ideal for shut-off of liquid, suction, discharge, recirculating liquid, hot gas, and oil lines in ammonia refrigeration systems. When used with seal caps, they are also suitable for R22, R134a, and other Hansen-approved refrigerants in steel piping systems.

APPLICATIONS: HAND EXPANSION VALVES

Hand expansion valves are ideal for liquid feed or circulating liquid overfeed evaporators, and high pressure or intermediate pressure liquid feed to accumulators, intercoolers, or recirculators. Other applications include defrost condensate relief, hot gas feed to evaporators, and equalizing evaporator to suction pressure after defrost. Bar handle or yellow seal caps distinguish them from shut-off valves.

ADVANTAGES

Extended neck, bolted bonnet, shut-off and hand expansion valves feature an extended bonnet to allow greater insulation clearance. Large bonnet bolts provide exceptional strength. These steel valves have much greater tensile strength, ductility, and impact resistance than cast iron. They also have a heavy, forged steel wall thickness for greater rigidity.

Their exclusive non-leak seal-plus-stem-packing virtually eliminates stem seal leakage. Additionally, the stem is polished to avoid packing wear, the precision stem threads avoid stem wobble, and the packing nut is close fitting to the stem to remove dirt particles and frost. This results in infrequent maintenance or tightening and virtually no refrigerant loss.

Hand expansion valves feature a slotted throttling plug which is more tolerant of dirt particles than common metal-seated tapered-plug expansion valves, and it is less susceptible to wire drawing. Also, they have near linear flow characteristics per turn open and are tight closing with Teflon seats.

CAUTION

Hansen valves are for refrigeration systems only. These instructions and related safety precautions must be read completely and understood before selecting, using, or servicing these valves. Only knowledgeable, trained refrigeration technicians should install, operate, or service these valves. Stated temperature and pressure limits should not be exceeded. Bonnets should not be removed from these valves unless the system has been evacuated to zero pressure. See also Safety Precautions in current List Price Bulletin and Safety Precautions Sheet supplied with product. Escaping refrigerant can cause injury, especially to the eyes and lungs.

INSTALLATION

All Hansen shut-off and hand expansion valves can be installed in horizontal or vertical pipe lines. Stems are normally installed horizontally, but, depending on the application, stems may be installed vertically. Globe valves should have stems horizontal to avoid liquid or vapor being trapped at the valve seat orifice. Inlet pressure or direction of flow for all valve sizes should normally be under valve seat disc. However, to avoid installing an angle valve with the stem down, it is better to install the valve with the normal flow opposite the direction of the arrow.

The valve stem should be opened several turns during welding to prevent heat damage to the seat disc. Normally, it is not necessary to disassemble these valves for installation welding. However, if welding is prolonged enough to overheat the valve body, a wet rag should be wrapped around the valve bonnet and upper body while welding.

Welds should be annealed as necessary in accordance with good practice. Painting valves and welds is recommended for corrosion protection. Pipe covering, where applied, should have a proper moisture barrier. Before putting valves into service, all pipe connections, valve seats, bonnet seals, and stem seals should be tested for leaks at pressure levels called for in appropriate codes.

Shut-off and hand expansion valves leading to the atmosphere must not be left unsupervised and must be plugged or capped to prevent corrosion inside the valve as well as leakage due to seat expansion, vibration, pressure shock, or improper opening. The valve seat should be cracked open to prevent hydrostatic expansion between the valve and the cap. Valves should never directly feed a water tank because of potential internal corrosion or seat opening caused by vibration.

INSULATION

Exterior valve dimensions for insulation are shown on pages 5 and 6.

TYPICAL SPECIFICATIONS

“Refrigerant shut-off and hand expansion valves from ½" (13 mm) through 1¼" (32 mm) sizes shall have steel bodies machined for socket weld or threaded connections, extended necks for insulation clearance, bolted bonnets, stainless steel stems, back-seating design for packing replacement, bonnet threads for installation of stem seal caps, and suitability for a safe working pressure of 400 psig (27 bar), as manufactured by Hansen Technologies Corporation or approved equal.”

**SHUT-OFF VALVE FLOW CAPACITIES
PIPING AND VALVE SIZING GUIDE FOR AMMONIA**

SERVICE	CONDITIONS				CAPACITIES							
	Temp. °F (°C)		PRESSURE PSIG (BAR)		½" (13 mm) TONS (kW)		¾" (20 mm) TONS (kW)		1" (25 mm) TONS (kW)		1¼" (32 mm) TONS (kW)	
Suction Lines Single Stage Compressor	+20	(-6.7)	33.5	(2.3)	-	-	-	-	8.6	(30)	15.8	(56)
	0	(-17.8)	15.7	(1.1)	-	-	-	-	5.7	(20)	10.4	(37)
Suction Lines Booster	-20	(-29.8)	3.6	(0.2)	-	-	-	-	4.2	(15)	7.4	(26)
	-40	(-40)	8.7"	(-0.3)	-	-	-	-	-	-	4.4	(15)
Liquid Overfeed Return Lines (4X)	+20	(-6.7)	33.5	(2.3)	-	-	-	-	5.0	(18)	9.1	(32)
	0	(-17.8)	15.7	(1.1)	-	-	-	-	3.4	(12)	6.3	(22)
	-20	(-28.9)	3.6	(0.2)	-	-	-	-	2.2	(8)	4.0	(14)
	-40	(-40)	8.7"	(-0.3)	-	-	-	-	-	-	2.4	(8)
Hot Gas Feed Hot Gas Main	+70	(+21.1)	114.1	(7.9)	2.2	(8)	4.3	(15)	7.3	(26)	14.1	(50)
	+70	(+21.1)	114.1	(7.9)	4.4	(15)	8.6	(30)	14.7	(52)	28.1	(99)
Compressor Discharge	+86	(+30)	154.5	(10.7)	-	-	-	-	12.6	(44)	24.1	(85)
Condenser Drains	+86	(+30)	-	-	6.0	(21)	14.5	(51)	24.0	(84)	50.0	(176)
Liquid Mains	+86	(+30)	-	-	28.3	(100)	53.1	(187)	90.8	(320)	143	(503)
Liquid Feed Branch	+86	(+30)	-	-	54.9	(193)	103	(363)	176	(620)	277	(975)
Liquid Overfeed Supply (4X)	+10	(-12.2)	-	-	9.0	(32)	17.0	(60)	29.0	(102)	46.0	(162)

SIZING GUIDE

These capacity recommendations are not affected by the length of the pipe line. These are approximate optimum sizes based on power costs versus the investment cost of piping and its total installed cost. Piping sized to these capacities will have 1°F (0.6°C) pressure drop for the following equivalent lengths:

- Suction lines 700 diameters
- Discharge lines 1400 diameters
- Liquid lines 2400 diameters

Example: Hansen angle socket weld valves have about 145 diameters of equivalent flow resistance, or 145/700 = 0.2°F (0.1°C) of equivalent pressure drop at the suction line capacities shown for a valve in a suction line. Globe valves equal about 225 diameters.

The rationale for the vapor line sizing was developed by William V. Richards in two papers: "Refrigerant Vapor Line Sizing Not Dependent on Length," 16th International Congress of Refrigeration, IIR, Paris, 1983, and "Practical Pipe Sizing for Refrigerant Vapor Lines," Sixth Annual Meeting, IIR, San Francisco, 1984.

SHUT-OFF VALVES FLOW COEFFICIENTS

NOMINAL SIZE INCH (MM)	ANGLE				GLOBE			
	FLOW COEFFICIENT Cv (Kv)		EQUIVALENT LENGTH* FEET (METERS)		FLOW COEFFICIENT Cv (Kv)		EQUIVALENT LENGTH* FEET (METERS)	
½ (13)	6	(5.2)	5	(1.5)	4	(3.5)	9	(2.7)
¾ (20)	9	(7.8)	8	(2.4)	8	(6.9)	8	(2.4)
1 (25)	19	(16)	7	(2.1)	15	(13)	11	(3.4)
1¼ (32)	21	(18)	36	(11)	16	(14)	46	(14)

*Schedule 80 pipe under 2" size

VALVE SIZING AND SETTING: HAND EXPANSION VALVES

To properly size and set hand expansion valves, determine the refrigerant, estimated pressure drop through the valve (not the system), evaporator load in tons (kW) and the circulating rate, or desired capacity of liquid makeup in tons (kW).

In general, the valve size selection should be based on the valve adjusted to 50% open. Select liquid line sizes so that velocity is limited to 7 ft/s (2.1 m/s) for ammonia, and 5 ft/s (1.5 m/s) for R22, to reduce the potential for liquid velocity shock (water hammer).

For Circulating Liquid Overfeed:

The steps below determine the required flow coefficient, Cv (Kv), and required turns open. For sizing assistance, contact Hansen. The circulating capacities assume 0°F (-20°C) evaporator temperature. For other evaporator temperatures these values will change only slightly due to density and latent heat variations.

1. Evaporator load, tons(kW) times the circulating rate = equivalent load, tons (kW) = _____.
2. Tons/Cv (kW/Kv) from table below = _____.
3. Equivalent load, tons (kW) divided by tons/Cv (kW/Kv) = required flow coefficient Cv (Kv) = _____.
4. Refer to Cv (Kv) Per Turns Open table. Valve size and turns open = _____.

Tons/Cv (kW/kv) CIRCULATING LIQUID OVERFEED

REFRIG	TEMP	PRESSURE DROP (ΔP)*				
		5 psi (0.3 bar)	10 psi (0.7 bar)	15 psi (1.0 bar)	20 psi (1.4 bar)	30 psi (2.0 bar)
R717	0°F (-20°C)	43 (165)	61 (250)	75 (301)	86 (350)	106 (426)
R22	0°F (-20°C)	10 (39)	14 (55)	18 (70)	20 (80)	25 (100)

*Pressure drop across the hand expansion valve.

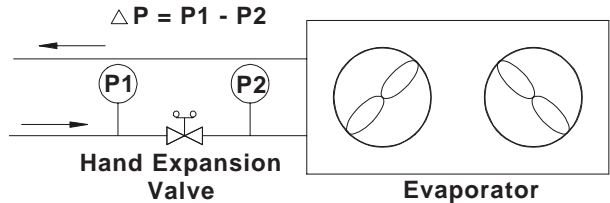

For Liquid Makeup:

Maximum capacities are possible with appropriate line sizing. The valve should be sized for intermittent, float-switch-operated flow. For example, a valve open 50% of the time feeding a 100 ton (350 kW) accumulator should be sized for 200 tons (700 kW). To determine required flow coefficient, Cv (Kv), estimate the approximate capacity in tons (kW) of liquid makeup desired and divide by 74.2 tons per Cv (302 kW per Kv) for ammonia, 16.4 tons per Cv (66.7 kW per Kv) for R22.

These ratings are based on 86°F (30°C) saturated liquid and 0°F (-20°C) evaporating temperature. Refer to the table Cv (Kv) PER TURNS OPEN for the appropriate valve size and turns open. For other evaporator temperatures, the values will change only slightly.

HAND EXPANSION VALVE Cv (Kv) PER TURNS OPEN

NOMINAL SIZE inch (mm)	TURNS OPEN								
	1	2	3	4	5	6	7	7.5	
THREADED OR WELDING	½ (13)	0.1 (0.1)	0.2 (0.2)	0.3 (0.3)	0.4 (0.3)	0.6 (0.5)	0.8 (0.7)	0.9 (0.8)	1.1 (1.0)
	¾ (20)	0.1 (0.1)	0.2 (0.2)	0.5 (0.4)	0.9 (0.8)	1.4 (1.2)	2.0 (1.7)	2.6 (2.2)	2.9 (2.5)
	1 (25)	0.1 (0.1)	0.3 (0.3)	0.6 (0.5)	1.2 (1.0)	2.2 (1.9)	3.3 (2.9)	4.2 (3.6)	4.5 (3.9)
	1¼ (32)	0.1 (0.1)	0.3 (0.3)	0.9 (0.8)	2.0 (1.7)	4.0 (3.5)	5.8 (5.0)	7.0 (6.1)	7.4 (6.4)

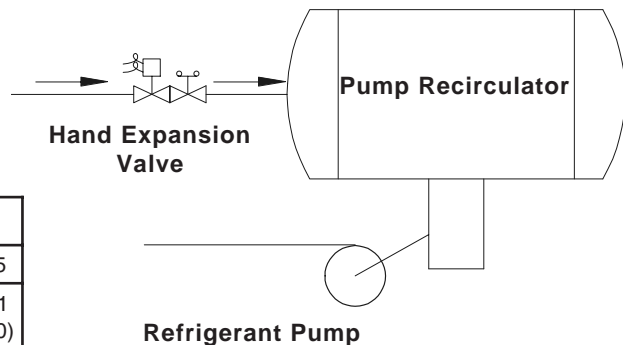

1/2" (13 MM) AND 3/4" (20 MM) EXTENDED NECK, BOLTED BONNET VALVE

INSTALLATION DIMENSIONS INCHES (MM)

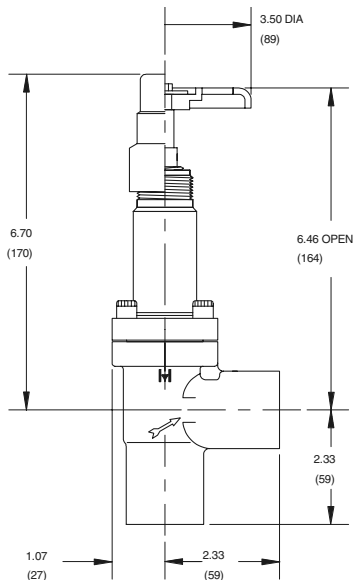
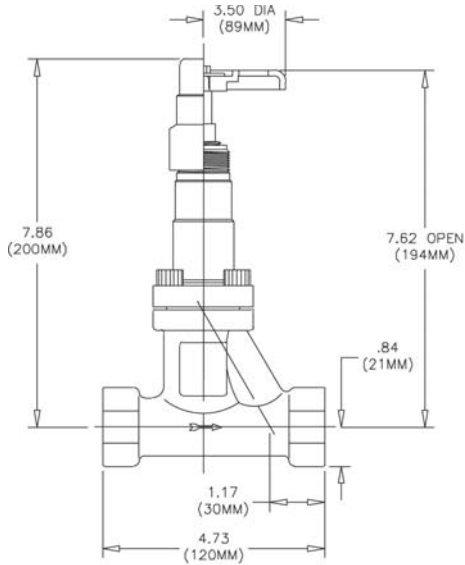
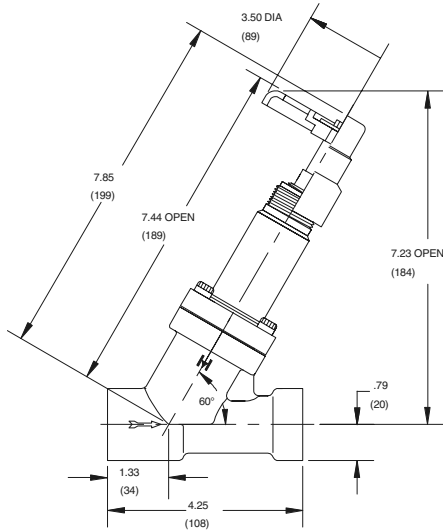

INSULATION DIMENSIONS INCHES (MM)

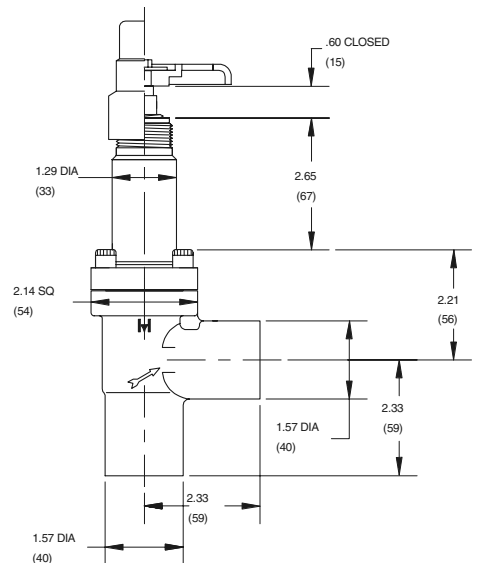
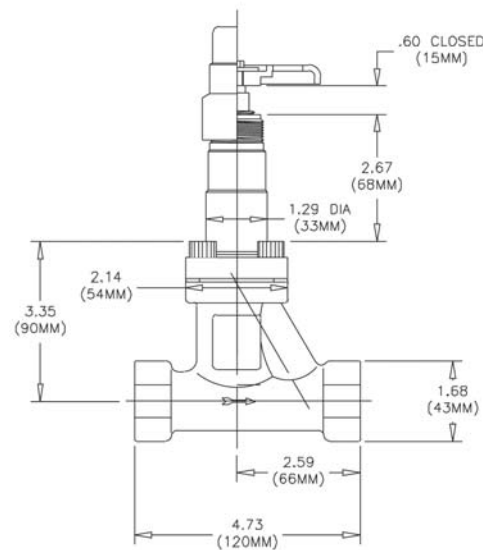
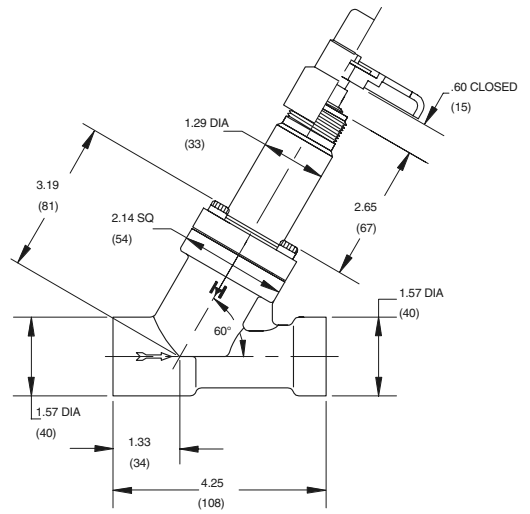

1" (25 MM) AND 1¼" (32 MM) EXTENDED NECK, BOLTED BONNET VALVE

INSTALLATION DIMENSIONS INCHES (MM)

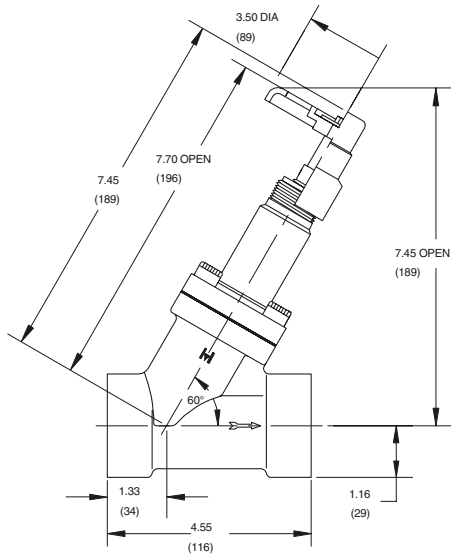

INSULATION DIMENSIONS INCHES (MM)

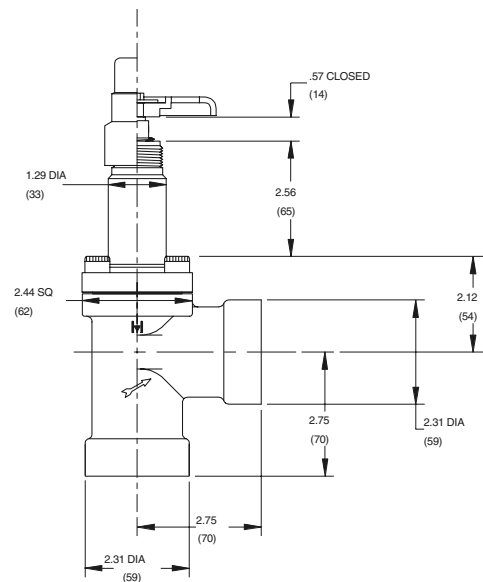
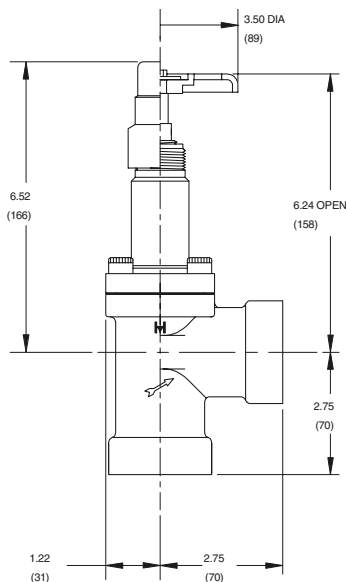
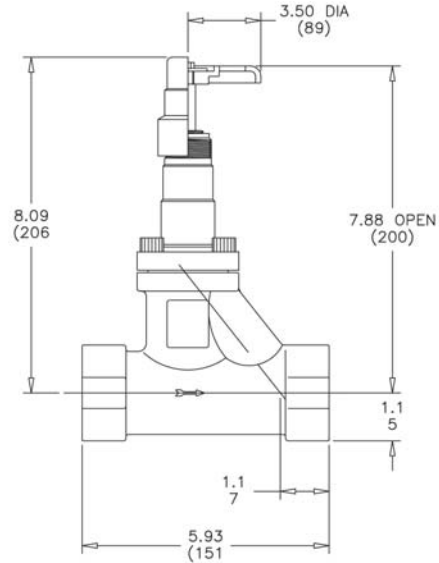
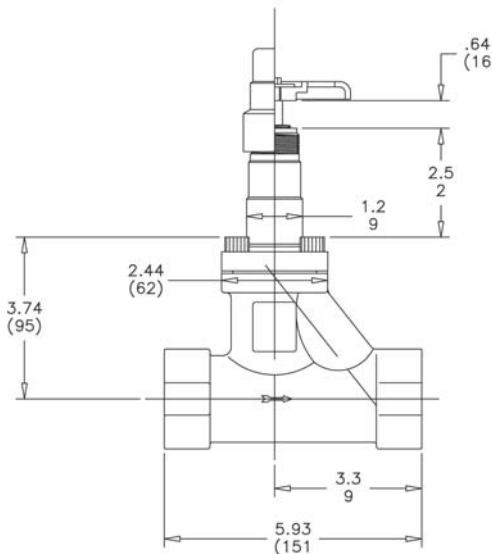
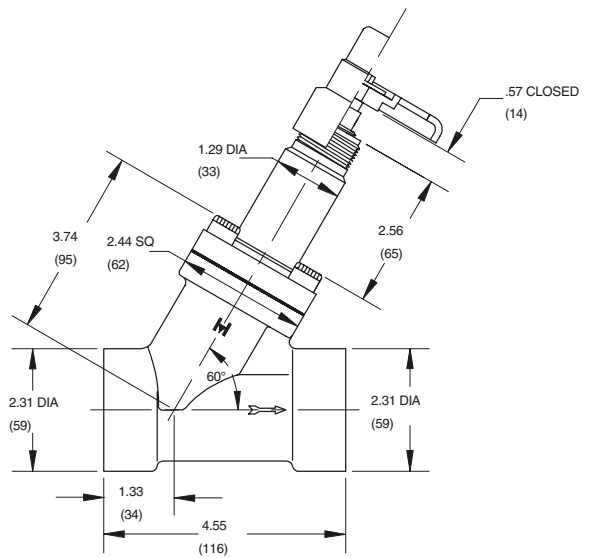

SHUT-OFF VALVES

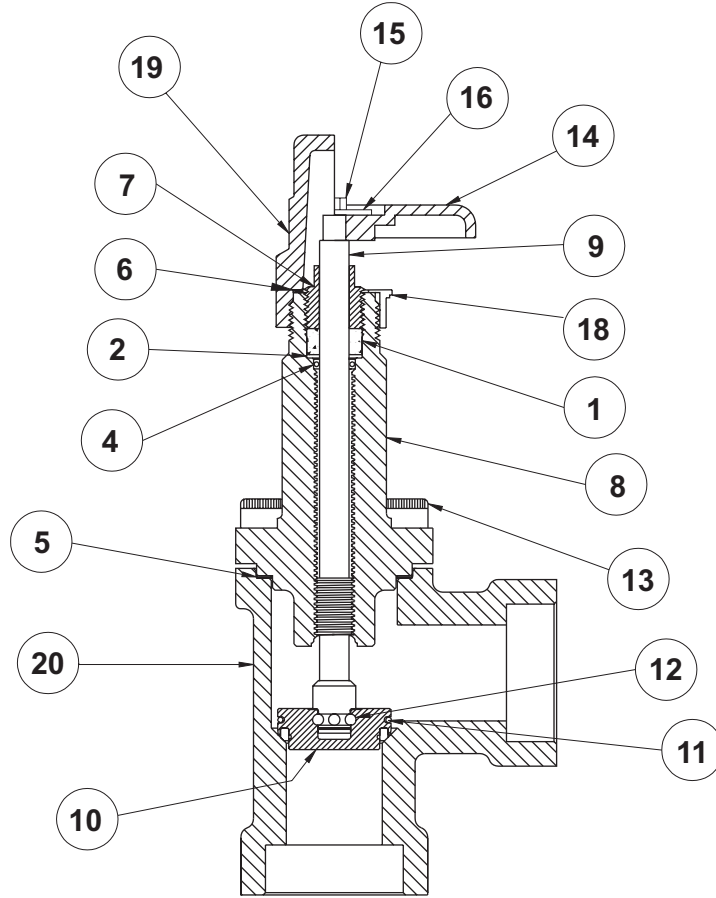

HAND EXPANSION VALVES

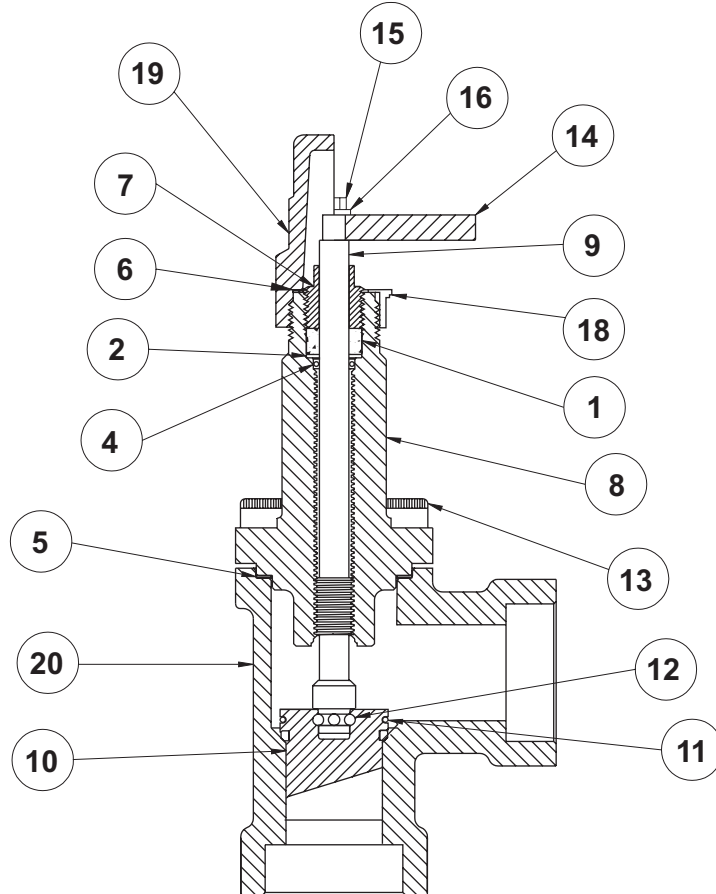

PARTS LIST

FOR SHUT-OFF VALVES ONLY

FOR HAND EXPANSION VALVES ONLY

ITEM	DESCRIPTION	QTY	PART NO
	Bonnet Assembly Kit 1/2", 3/4" (13 mm, 20 mm)		50-1094
	Bonnet Assembly Kit 1, 1 1/4" (25 mm, 32 mm)		50-1095
	<i>Above kits consist of:</i>		
8	Bonnet 1/2", 3/4"	1	50-0743
	Bonnet 1", 1 1/4"	1	50-0774
9	Stem	1	50-0765
10	Disc Assembly 1/2", 3/4"	1	50-0803
	Disc Assembly 1", 1 1/4"	1	50-0804
11	Ball Retainer 1/2", 3/4"	1	50-0439
	Ball Retainer 1", 1 1/4"	1	50-0026
12	Balls	10	50-0016
13	Bonnet Bolts	4	50-0813
	Gasket Kit 1/2", 3/4"	1	50-1040
	Gasket Kit 1", 1 1/4"	1	50-1040
	Disc Assembly Kit 1/2", 3/4" (13 mm, 20 mm)		50-1042
	Disc Assembly Kit 1, 1 1/4" (25 mm, 32 mm)		50-1004
	<i>Above kits consist of:</i>		
5	Bonnet Gasket 1/2", 3/4"	1	50-0805
	Bonnet Gasket 1", 1 1/4"	1	50-0806
10	Disc Assembly 1/2", 3/4"	1	50-0803
	Disc Assembly 1", 1 1/4"	1	50-0804
11	Ball Retainer 1/2", 3/4"	1	50-0439
	Ball Retainer 1", 1 1/4"	1	50-0026
12	Balls	10	50-0016
	Handwheel Kit		50-1005
	<i>Above kit consists of:</i>		
14	Handwheel	1	50-0953
15	Screw	1	50-0479
16	Nameplate	1	50-0094
18	Bonnet Thread Cap	1	50-0434
	Seal Cap Kit		50-1036
	<i>Above kit consists of:</i>		
6	Seal Cap O-Ring	1	50-0432
19	Seal Cap	1	50-0423

ITEM	DESCRIPTION	QTY	PART NO
	Throttling Plug Kit 1/2" (13 mm)		50-1061
	Throttling Plug Kit 3/4" (20 mm)		50-1062
	Throttling Plug Kit 1" (25 mm)		50-1015
	Throttling Plug Kit 1 1/4" (32 mm)		50-1016
	<i>Above kits consist of:</i>		
5	Bonnet Gasket 1/2", 3/4"		50-0805
	Bonnet Gasket 1", 1 1/4"		50-0806
10	Throttling Plug 1/2"		50-0877
	Throttling Plug 3/4"		50-0878
	Throttling Plug 1"		50-0881
	Throttling Plug 1 1/4"		50-0882
11	Ball Retainer 1/2", 3/4"		50-0439
	Ball Retainer 1", 1 1/4"		50-0026
12	Balls		50-0016
	Bar Handle Kit		50-1012
	<i>Above kit consists of:</i>		
14	Bar Handle	1	50-0952
15	Screw	1	50-0479
16	Washer	1	50-0129
18	Bonnet Thread Cap	1	50-0434
	Seal Cap Kit		50-1049
	<i>Above kit consists of:</i>		
6	Seal Cap O-Ring	1	50-0432
19	Seal Cap (Yellow)	1	50-0423
	Bonnet Kit 1/2" (20 mm)		50-1104
	Bonnet Kit 3/4" (20 mm)		50-1105
	Bonnet Kit 1" (25 mm)		50-1106
	Bonnet Kit 1 1/4" (32 mm)		50-1107

**FOR SHUT-OFF VALVES AND
HAND EXPANSION VALVES**

ITEM	DESCRIPTION	QTY	PART NO
	Gasket Kit ½", ¾" (13 mm, 20 mm)		50-1040
	Gasket Kit 1, 1¼" (25 mm, 32 mm)		50-1040
	<i>Above kits consist of:</i>		
1	Stem Packing	1	50-0045
2	Stem Washer	1	50-0046
4	Stem O-Ring	1	50-0179
5	Bonnet Gasket ½", ¾"	1	50-0805
	Bonnet Gasket 1", 1¼"	1	50-0806
6	Seal Cap O-Ring	1	50-0432
7	Packing Nut	1	50-0933
20	Body	1	
	Globe, ½" SW		50-0736
	Globe, ¾" SW		50-0739
	Globe, 1" SW		50-0784
	Globe, 1¼" SW		50-0788
	T-Globe, ½" SW		50-2338
	T-Globe, ¾" SW		50-2341
	T-Globe, 1" SW		50-2343
	T-Globe, 1¼" SW		50.2345
	Angle, ½" SW		50-0767
	Angle, ¾" SW		50-0770
	Angle, 1" SW		50-0778
	Angle, 1¼" SW		50-0781
	Globe, ½" BW		50-0737
	Globe, ¾" BW		50-0740
	Globe, 1" BW		50-0785
	Globe, 1¼" BW		50-0787
	T-Globe, ½" BW		50-2339
	T-Globe, ¾" BW		50-2342
	T-Globe, 1" BW		50-2344
	T-Globe, 1¼" BW		50-2346
	Angle, ½" BW		50-0768
	Angle, ¾" BW		50-0771
	Angle, 1" BW		50-0779
	Angle, 1¼" BW		50-0782
	Globe, ½" FPT		50-0738
	Globe, ¾" FPT		50-0741
	Globe, 1" FPT		50-0786
	Globe, 1¼" FPT		50-0789
	T-Globe, ½" FPT		50-2300
	T-Globe, ¾" FPT		50-2312
	T-Globe, 1" FPT		50-2301
	T-Globe, 1¼" FPT		50-2313
	Angle, ½" FPT		50-0769
	Angle, ¾" FPT		50-0772
	Angle, 1" FPT		50-0780
	Angle, 1¼" FPT		50-0783

VALVE SEAT

To inspect or replace the valve seat disc, isolate the valve from the system and safely pump out all refrigerant to zero pressure. With the stem open several turns, carefully remove the bonnet assembly. Proceed slowly and cautiously since some refrigerant may still be inside the valve body. Evenly loosen all bolts one to two turns. Using a screwdriver, break the seal between the bonnet and valve body, proceeding cautiously to avoid any refrigerant which may still remain inside the valve body. Remove the bonnet bolts and bonnet assembly, being careful not to damage the Teflon seat disc surface.

If the conical seat surface in the body is marred, remove the marks with emery paper by hand or with a power drill. If the seat disc is damaged, replace the entire disc assembly by first removing the ball retainer ring and ball bearings. Install a new disc assembly, including new bearings and retainer ring. Install new stem packing, stem o-ring, stem washers, and bonnet gasket, if necessary. Reassemble the bonnet into the valve body with the stem still open several turns. Bonnet bolts require a torque of 30 ft-lbs (40 Nm). Evenly tighten in a diagonal crossing pattern.

STEM PACKING

When verifying the tightness of the packing nut, use an 8" adjustable wrench. Extrusion of some black graphite packing material along the stem is normal. If the o-ring or the adjustable packing ever needs replacement as evidenced by refrigerant or oil leakage at the stem, open the valve stem firmly to the back-seat position. This separates the o-ring and packing from the system refrigerant. See the CAUTION section. Remove the packing nut carefully and then use a wire hook or a small blade screwdriver to remove the packing and o-ring. Take care not to scratch the stem or bonnet sealing surfaces. Carefully install a new lubricated stem o-ring, stem washer, and stem packing. Tighten the packing nut only enough to give the handwheel slight turning friction.

SERVICE AND MAINTENANCE

Hansen extended neck, bolted bonnet, shut-off and hand expansion valves require practically no service or maintenance. Stem leakage, a common problem, is almost entirely eliminated by the combination of polished stainless steel stems and reliable, conventional, adjustable packing supplementing fluid-tight o-ring stem seals. For optimum maintenance, occasional cleaning of the valve stem with a soft rag and refrigerant oil is helpful. The patented o-ring stem seal design permits low torque operation to open and close the valve.

WARRANTY

Hansen valves are guaranteed for one year F.O.B. our plant. No consequential damages or field labor is included.

ORDERING INFORMATION

T H R E E D	Nominal Size inch (mm)	SHUT-OFF					
		Handwheel			Seal Cap		
		Globe	T-Globe	Angle	Globe	T-Globe	Angle
	½ (13)	GTB050H	GTB051H	ATB050H	GTB050C	GTB051C	ATB050C
	¾ (20)	GTB075H	GTB076H	ATB075H	GTB075C	GTB076C	ATB075C
	1 (25)	GTB100H	GTB101H	ATB100H	GTB100C	GTB101C	ATB100C
	1¼ (32)	GTB125H	GTB126H	ATB125H	GTB125C	GTB126C	ATB125C
	Nominal Size inch (mm)	HAND EXPANSION					
		Bar Handle			Seal Cap		
		Globe	T-Globe	Angle	Globe	T-Globe	Angle
½ (13)	RTB050H	RTB051H	VTB050H	RTB050C	RTB051C	VTB050C	
¾ (20)	RTB075H	RTB076H	VTB075H	RTB075C	RTB076C	VTB075C	
1 (25)	RTB100H	RTB101H	VTB100H	RTB100C	RTB101C	VTB100C	
1¼ (32)	RTB125H	RTB126H	VTB125H	RTB125C	RTB126C	VTB125C	
S O C K E T W E L D	Nominal Size inch (mm)	SHUT-OFF					
		Handwheel			Seal Cap		
		Globe	T-Globe	Angle	Globe	T-Globe	Angle
	½ (13)	GSB050H	GSB051H	ASB050H	GSB050C	GSB051C	ASB050C
	¾ (20)	GSB075H	GSB076H	ASB075H	GSB075C	GSB076C	ASB075C
	1 (25)	GSB100H	GSB101H	ASB100H	GSB100C	GSB101C	ASB100C
	1¼ (32)	GSB125H	GSB126H	ASB125H	GSB125C	GSB126C	ASB125C
	Nominal Size inch (mm)	HAND EXPANSION					
		Bar Handle			Seal Cap		
		Globe	T-Globe	Angle	Globe	T-Globe	Angle
½ (13)	RSB050H	RSB051H	VSB050H	RSB050C	RSB051C	VSB050C	
¾ (20)	RSB075H	RSB076H	VSB075H	RSB075C	RSB076C	VSB075C	
1 (25)	RSB100H	RSB101H	VSB100H	RSB100C	RSB101C	VSB100C	
1¼ (32)	RSB125H	RSB126H	VSB125H	RSB125C	RSB126C	VSB125C	
B U T T W E L D	Nominal Size inch (mm)	SHUT-OFF					
		Handwheel			Seal Cap		
		Globe	T-Globe	Angle	Globe	T-Globe	Angle
	½ (13)	GWB050H	GWB051H	AWB050H	GWB050C	GWB051C	AWB050C
	¾ (20)	GWB075H	GWB076H	AWB075H	GWB075C	GWB076C	AWB075C
	1 (25)	GWB100H	GWB101H	AWB100H	GWB100C	GWB101C	AWB100C
	1¼ (32)	GWB125H	GWB126H	AWB125H	GWB125C	GWB126C	AWB125C
	Nominal Size inch (mm)	HAND EXPANSION					
		Bar Handle			Seal Cap		
		Globe	T-Globe	Angle	Globe	T-Globe	Angle
½ (13)	RWB050H	RWB051H	VWB050H	RWB050C	RWB051C	VWB050C	
¾ (20)	RWB075H	RWB076H	VWB075H	RWB075C	RWB076C	VWB075C	
1 (25)	RWB100H	RWB101H	VWB100H	RWB100C	RWB101C	VWB100C	
1¼ (32)	RWB125H	RWB126H	VWB125H	RWB125C	RWB126C	VWB125C	



6827 High Grove Boulevard
 Burr Ridge, Illinois 60527 USA
 Tel: 630-325-1565
 Fax: 630-325-1572
 Toll-free: 800-426-7368
 E-mail: info@hantech.com
<http://www.hantech.com>