



**Specifications, Applications,
Service Instructions & Parts**

**REFRIGERANT
PRESSURE-RELIEF
VALVE**

**For Ammonia and
Halocarbon Gas Service
Safety Relief to Atmosphere**

INTRODUCTION

Designed to provide emergency relief from excessive pressure in refrigerant-containing vessels, they are built in strict conformance with ASME Boiler and Pressure Vessel Code requirements for safety relief devices. **Each valve bears the ASME code symbol of certification (UV).** Their capacities are rated by the National Board of Boiler and Pressure Vessel Inspectors. These tamper-resistant valves are accurately set and sealed by qualified technicians at the factory.

APPLICATIONS

Hansen pressure-relief valves help meet the requirements of ANSI/ASHRAE 15-2001 Safety Standard for Refrigeration Systems as well as other worldwide codes. This standard requires pressure vessels of all refrigeration systems to be protected by a pressure relief device or other approved means to safely relieve pressure in the event of fire or other abnormal conditions. Once installed, a properly selected Hansen pressure-relief valve is ready to vent to atmosphere any temporary excessive overpressure inside of a vessel. After discharge, these valves will attempt to reseal to minimize loss of refrigerant. However, once any relief valve has discharged, it must be replaced as soon as possible because debris may have settled on the seat during discharge.

Hansen pressure-relief valves should be connected to the **vapor space** of refrigerant vessels, heat exchangers, oil pots, oil stills, pilot receivers, and elsewhere as may be required by various codes.

Where dual pressure-relief valves are required, Hansen offers the three-way valves and other components necessary for assembly; see pg 4. Rupture disc assemblies are required when using Hansen pressure-relief valves for halocarbon applications because the high cost of such refrigerants demands extreme tightness, see bulletin K209.

R-Series capacity valves are designed for use where inlet piping pressure drop including three-way valves must be less than 3% of the pressure setting.

KEY FEATURES

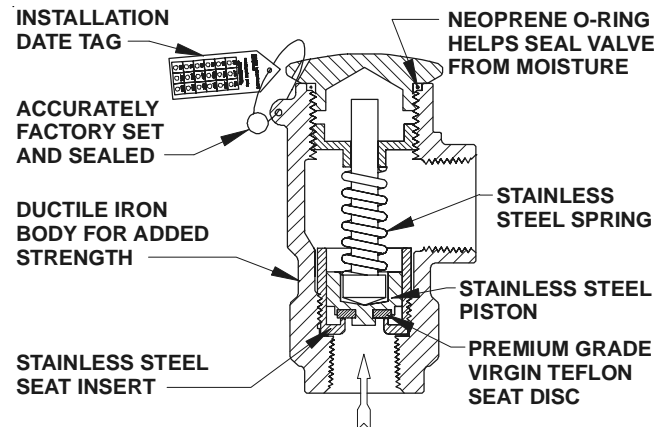

ORDERING INFORMATION

CAT NO	THREADED CONNECTIONS (NPT)	
	BOTTOM INLET	SIDE OUTLET
H5600R H5600A	1/2" FPT	3/4" FPT
H5601	1/2" FPT	1" FPT
H5602 H5602R H5632R	3/4" FPT	1" FPT
H5613 H5633R	1" FPT	1 1/4" FPT
H5604 H5634R	1 1/4" FPT	1 1/2" FPT

TO ORDER:

Specify catalog number, inlet/outlet connection size, and pressure setting. For halocarbon applications, a rupture disc assembly is required. See pg 4 and Hansen Bulletin K209.

Standard pressure settings: 150*, 175, 200, 225, 250*, 275, 300*, 325, and 350 psig. (*Stock pressure settings.) Custom pressure settings available; may require extra delivery time. The new "R" Series Valves have reduced capacities, see pg 2.

VALVE SIZING AND SELECTION

Step 1: Use the formula below, per ANSI/ASHRAE 15-2001 Safety Standard for Refrigeration Systems to calculate the minimum required discharge capacity in pounds of air per minute. When selecting a dual pressure-relief valve system, be aware that each individual valve must have sufficient capacity to protect the vessel.

$$C = fDL$$

- C** = minimum required discharge capacity of the relief device in pounds of air per minute.
- f** = factor for ammonia refrigerant is 0.5**, factor for R-22 and R-134a refrigerants is 1.6**, for other refrigerants see ANSI/ASHRAE 15 or contact factory.
- D** = outside diameter of vessel in feet.
- L** = length of vessel in feet.

** This factor is not suitable when combustible materials are within 20 feet (6.1 m) of the pressure vessel; refer to relevant codes for corrected sizing method.

Example: To determine the minimum required capacity of a relief valve for a vessel containing ammonia that measures 16 feet in length and 6 feet in outside diameter, the equation would be as follows: $0.5 \times 6 \times 16 = 48 \text{ lb/min}$

Step 2: Determine the pressure setting needed. This should be at or below the design pressure of the vessel. The relief setting should also be at least 25% above the maximum expected operating pressure to avoid "weeping" of relief valves. The setting may be below (never above) the design pressure of the vessel, but it is sometimes best to match vessel design pressure and relief setting to minimize the likelihood of a discharge.

Step 3: Refer to the Valve Capacity Ratings below and select the valve with the required capacity (C) at the desired pressure setting.

PRESSURE-RELIEF VALVE CAPACITY RATINGS (NATIONAL BOARD CERTIFIED)

CAT NO	AIR CAPACITY	STANDARD PRESSURE SETTINGS (psig)									
		150	175	200	225	250	275	300	325	350	400
H5600R H5602R	lb/min	10.5	12.2	13.8	15.4	17.0	18.6	20.2	21.8	23.5	26.7
	scfm	140	162	183	205	226	248	269	290	312	355
H5632R	lb/min	22	25	29	32	36	39	42	46	49	56
	scfm	292	337	382	427	472	517	561	606	651	741
H5633R	lb/min	28	33	37	41	46	50	54	59	63	72
	scfm	377	435	492	550	608	665	723	781	839	954
H5634R	lb/min	34	39	44	49	54	60	65	70	75	85
	scfm	449	518	586	655	724	793	861	930	999	1136
H5600A	lb/min	31.3	36.1	40.9	45.7	50.5	55.3	60.1	64.9	69.7	79.3
	scfm	417	480	544	608	672	736	799	863	927	1055
H5601 H5602	lb/min	35.8	41.3	46.8	52.2	57.7	63.2	68.6	74.1	79.6	
	scfm	476	549	622	695	768	841	913	986	1059	
H5613	lb/min	53.0	61.1	69.2	77.3	85.4	93.5	101.6	109.7	117.8	134
	scfm	704	812	920	1028	1136	1243	1351	1459	1567	1782
H5604	lb/min	72.0	83.0	94.0	105.1	116.1	127.1	138.1	149.1	160.2	182
	scfm	958	1104	1251	1397	1544	1691	1837	1984	2130	2423

IMPORTANT NOTE: These are atmospheric relief valves. Settings equal pressure above atmosphere when outlet is connected via proper Schedule 40 piping to the atmosphere (outside). (scfm = Standard Cubic Feet per Minute)

INSTALLATION DIMENSIONS

CAT NO	THREADED CONNECTIONS (NPT)		A	B	C
	BOTTOM INLET	SIDE OUTLET			
H5600A H5600R	1/2" FPT	3/4" FPT	2.13"	2.75"	1.63"
		1" FPT			
H5601 H5602R H5632R	3/4" FPT	1" FPT			
H5613 H5633R	1" FPT	1 1/4" FPT	3.00"	4.13"	2.25"
H5604 H5634R	1 1/4" FPT	1 1/2" FPT			

R-Series capacity valves have green installation date tags, while all others are blue.

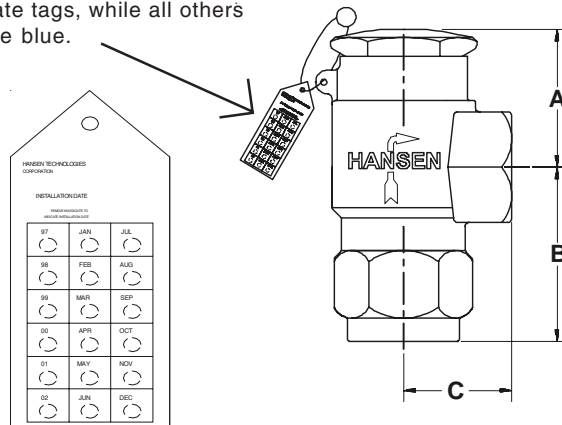

INSTALLATION

Hansen pressure-relief valves come with an installation date tag to identify the number of years the valve has been in service. R-series capacity valves have green installation date tags, while all others are blue. When installing the pressure-relief valve, remove the knockouts corresponding to the current year and month. Use a pen to push the knockout partially through the tag and tear-away from other side.

Pressure-relief valves for ammonia refrigeration are subject to preventative inspection and maintenance or periodic replacement (Risk Management Program RMP). Normal replacement is five years from installation. However, once a valve discharges it must be replaced as soon as possible. Self-reseating is not dependable because of dirt.

Protect pressure-relief valves from dirt and moisture. Match capacity on valve nameplate to system document as specified by system designer and based upon protected vessel volume. Mount valve directly at the vapor space of pressure vessel or on connecting non-valved vapor piping as close to the vessel as possible. Pressure-relief valves should be installed upright, although horizontal installation is possible.

MATERIAL SPECIFICATIONS

Body: Ductile iron, ASTM A395
Piston: Stainless steel
Spring: Stainless steel
Seat Insert: Stainless steel
Seat Discs: Premium grade virgin Teflon® (PTFE)
Cap: Steel
Cap O-ring: Neoprene
Maximum Temperature Rating: 240F (115°C)
Safe Working Pressure: 400 psig (27 bar)
Setting Range: 150 to 400 psig (10.4 to 27 bar)

GENERAL PRECAUTIONS

Never expose your face or body to a connected relief valve exit or piping.

Make sure the valve setting and capacity (see Nameplate Information Section) meet the requirements per system design in accordance with local and national regulations. Be sure to isolate the valve and related piping from the refrigeration system and pump out pressure to zero before attempting to install or replace any pressure-relief valve. Avoid residual refrigerant when doing so.

Remove the shipping caps from both the inlet and outlet before installation. Install the pressure-relief valve to the pressure vessel at a location above the liquid refrigerant level. These valves are for gas relief only. Do not install shut-off valves in line with pressure-relief valves. Install valves in locations where they will not be damaged by moving equipment such as lift trucks, etc. Install valves in a manner that enables them to be replaced.

When a dual pressure relief system is being put into service, the three-way valve stem should be positioned so that only one valve is exposed to pressure. While the valve can be either frontseated (front port is closed) or backseated (back port is closed), the backseated position is recommended because it takes pressure off the packing and reduces the possibility of packing leaks.

Vent the relief valve exit to a safe outdoor location in an approved manner away from people and building openings. Do not install valves in a refrigerated space unless precautions are taken to prevent moisture migration into the valve body or the relief vent line. Avoid trapped ice build-up between valves and other equipment.

Only apply thread sealing compound to external pipe threads and use a modest amount to avoid getting compound inside the valve. Use brackets or hangers to support the pipe and prevent the valve from being overly

stressed. Do not put undue stress on the valve by using it to stretch or align pipe.

Pressure test all valves and related piping for leaks. When testing a dual pressure relief system, the three-way valve stem should be in the mid position (only during testing), ensuring that all valves are properly leak tested. Do not discharge valves prior to installation or when pressure testing. Never attempt to reset or change the valve setting. **Always replace pressure-relief valves once they have discharged.**

SERVICE AND MAINTENANCE

These tamper-resistant pressure relief valves are accurately factory set and do not require any field adjustments whatsoever. They are intended for one time over-pressure operation and should be replaced immediately after discharging because setting or seat tightness may be altered. Every six months, relief valves shall be visually inspected for corrosion or accumulation of scale and for leaks. Normally pressure-relief valves should be removed and replaced with new valves at least every five years. Even when simply replacing an existing valve, a review of requirements per current local and national code is advisable. Valves should not be removed unless system has been evacuated to zero pressure.

CAUTION

Hansen pressure-relief valves and three-way dual shut-off valves are only for refrigerant gas relief and cannot be used for liquid relief. These instructions and related safety precautions must be read and completely understood before selecting, using, or servicing these valves. Only knowledgeable, trained refrigeration mechanics should install, operate, or service valves. Stated temperature and pressure limits should not be exceeded. Valves should not be removed unless system has been evacuated to zero pressure. See also safety precautions in current List Price Bulletin and Safety Precautions Sheet supplied with product. Escaping refrigerant might cause personal injury, particularly to eyes and lungs.

WARRANTY

Hansen valves are guaranteed against defective materials and workmanship for one year F.O.B. our factory. No consequential damage or field labor is included.

NAMEPLATE INFORMATION

The nameplate, located on the side of Hansen pressure-relief valves, contains important information about the valve pressure setting, capacity and date of manufacture. The serial number traces the month and year the valve was built. This is a helpful guide in establishing an approximate date of service. Example: A valve with Serial No. 05A 99, indicates that it was built in May of 1999. See nameplate below for location of data.

- 1 CATALOG NUMBER.
- 2 AIR CAPACITY ACCORDING TO THE SET PRESSURE.
- 3 SET PRESSURE.
- 4 INLET AND OUTLET SIZE
- 5 MONTH OF MANUFACTURE AND THE CURRENT REVISION LETTER
- 6 YEAR OF MANUFACTURE

Pressure-Relief Valve			
Cat. No.	①		
Air Capacity scfm	②		
Set Pressure psig	③		
Size Inch	Inlet ④	Outlet ④	UV NB
Serial No.	⑤	⑥	
HANSEN TECHNOLOGIES CORPORATION Burr Ridge, IL 60521 USA			

DUAL PRESSURE-RELIEF VALVES

In accordance with ANSI/ASHRAE 15-2001 Safety Standard for Refrigeration Systems, pressure vessels having 10 cubic feet or more of internal gross volume, shall be fitted with dual pressure-relief valves. This is typically accomplished using a pair of pressure-relief valves interconnected via a three-way dual shut-off valve. Even on smaller vessels this arrangement is often preferred because one valve remains operational, while the other is being replaced; thereby eliminating the need to remove refrigerant from the vessel. Hansen can provide any or all the necessary components, in addition to the actual relief valves, as follows:

THREE-WAY DUAL SHUT-OFF VALVES

These rugged, forged steel bodied valves facilitate the parallel installation of pressure-relief valves. Because three-way valves will not isolate both pressure-relief valves simultaneously, they are considered the only acceptable type of shut-off valve for use with refrigerant relief piping. Their durable metal-to-metal seating and patented non-leak packing plus o-ring stem seal design combine for long, trouble-free service. Inlet and outlet connections are threaded female NPT all the same size.

Shown below is a three-way dual shut-off valve in the stem out position (backseated). The valve stem should be positioned so that only one pressure-relief valve is activated. While the valve can be either frontseated (front port is closed) or backseated (back port is closed), the backseated position (shown) is recommended for normal use because it takes pressure off the packing and reduces the possibility of packing leaks.

THREE-WAY DUAL SHUT-OFF VALVE (SHOWN BACKSEATED)

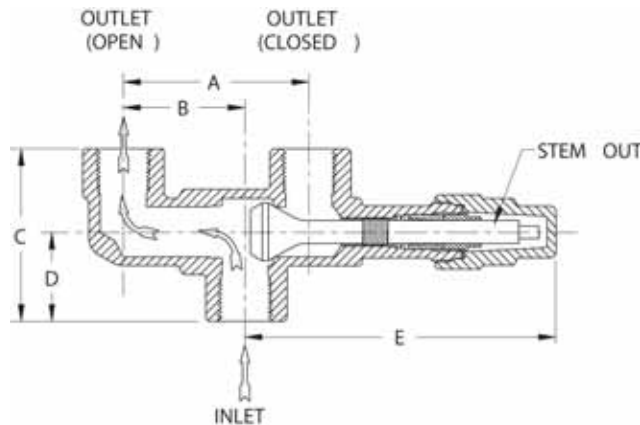

CAT NO	CONNECTION SIZE	DIMENSIONS (INCHES)				
		A	B	C	D	E
H8021	1/2" FPT	3.63"	2.38"	3.38"	1.75"	6.00"
H8022	3/4" FPT					
H8024	1" FPT	5.88"	3.75"	4.00"	2.00"	8.00"
H8025	1 1/4" FPT					

TO ORDER:

Please specify three-way dual shut-off valve catalog number and connection size.

DUAL AND DUAL UNION PRESSURE-RELIEF KITS

Hansen's Dual Pressure-Relief Valve Kit includes one (1) three-way dual shut-off valve, two (2) pressure-relief valves, and two (2) nipples; for field assembly. The Dual kit is available 1/2" to 1 1/4". The Dual Union Pressure-Relief Valve Kit consists of one (1) three-way dual shut-off valve, two (2) pressure-relief valves, four (4) unions and a single outlet. Unions at the inlets and outlets of both pressure-relief valves facilitate valve replacement. The Dual Union kit is only available with 1/2" & 3/4" inlet sizes. Both kits require field assembly. Assembled kits are shown below.



DUAL KIT



DUAL UNION KIT

TO ORDER:

Add "D" suffix for Dual Kit or "DU" suffix for Dual Union Kit to pressure-relief valve catalog number. Specify inlet/outlet connection size and pressure setting.

RUPTURE DISC ASSEMBLIES

Hansen rupture disc assemblies (RDAs) are used to indicate which pressure-relief valve has discharged. A pressure-relief valve will reseat after discharging. However, a rupture disc remains open after bursting. An installed pressure gauge or switch (required by code) provides a visual or electronic indication that the rupture disc has burst.



Also, rupture disc assemblies provide a hermetic seal to help eliminate any possibility of minute losses of refrigerant via pressure-relief valve seat materials. Rupture disc assemblies are required when using Hansen pressure-relief valves in halocarbon applications because the high cost of such refrigerants demands extreme tightness. For more detailed information, including ordering and ASME capacity requirements, see Hansen Bulletin K209.

HANSEN TECHNOLOGIES CORPORATION

6827 High Grove Boulevard
Burr Ridge, Illinois 60527 USA

Tel: (630) 325-1565 Fax: (630) 325-1572

Toll: (800) 426-7368 <http://www.hantech.com>

© 2004 Hansen Technologies Corporation