

# M3Q ELECTRONIC ACTUATOR AND PILOT

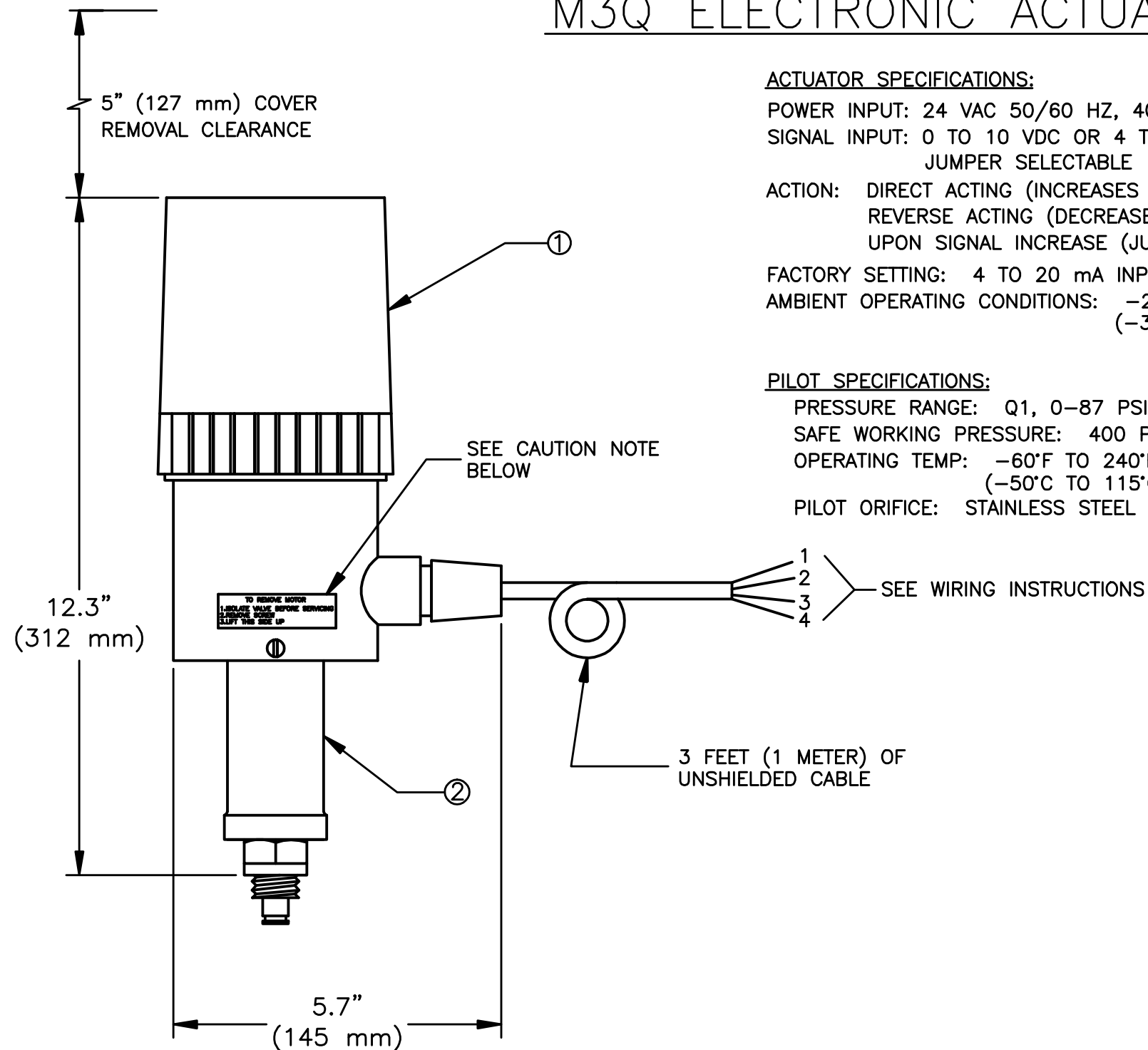

## ACTUATOR SPECIFICATIONS:

POWER INPUT: 24 VAC 50/60 HZ, 40 VA.  
 SIGNAL INPUT: 0 TO 10 VDC OR 4 TO 20 mA  
 JUMPER SELECTABLE  
 ACTION: DIRECT ACTING (INCREASES PRESSURE; DA) OR  
 REVERSE ACTING (DECREASES PRESSURE: RA)  
 UPON SIGNAL INCREASE (JUMPER SELECTABLE).  
 FACTORY SETTING: 4 TO 20 mA INPUT, DIRECT ACTING.  
 AMBIENT OPERATING CONDITIONS: -20°F TO 120°F  
 (-30°C TO 50°C)

## PILOT SPECIFICATIONS:

PRESSURE RANGE: Q1, 0-87 PSIG (0 - 6 BAR)  
 SAFE WORKING PRESSURE: 400 PSIG (27 BAR)  
 OPERATING TEMP: -60°F TO 240°F  
 (-50°C TO 115°C)  
 PILOT ORIFICE: STAINLESS STEEL

## ACTUATOR OPERATION:

THIS ACTUATOR IS DESIGNED TO OPERATE IN CONJUNCTION WITH ANY PI/PID/FUZZY LOGIC CONTROLLER WITH A 4-20mA OR 2-10 VDC SIGNAL OUTPUT. THE ACTUATOR COMES FACTORY SET TO ACCEPT A 4-20 mA SIGNAL. THE ACTUATOR IS ALSO FACTORY SET TO DIRECT ACTING. IN DIRECT ACTING MODE AN INCREASE IN SIGNAL TO THE ACTUATOR LEADS TO AN INCREASE IN PRESSURE SETTING. THE ACTUATOR CAN ALSO BE SET TO REVERSE ACTING (i.e. INCREASE IN SIGNAL LEADS TO A DECREASE IN PRESSURE SETTING).

## WIRING INSTRUCTIONS:

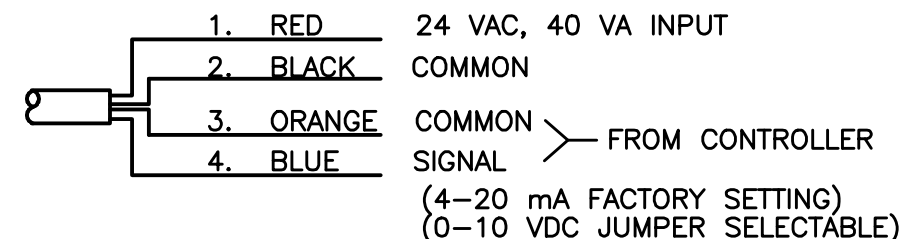

ALSO REFER TO 7502-32

## PARTS LIST

ITEM	DESCRIPTION	QTY.	PART #
1	MOTOR ASSY KIT	1	75-2021
2	PILOT ASSY KIT	1	75-2022

**CAUTION:** DO NOT ATTEMPT TO REMOVE ACTUATOR WITHOUT COMPLETELY ISOLATING THE MAIN VALVE. BEFORE OPENING OR DIS-ASSEMBLING THE PILOT OR VALVE FOR SERVICING, BE SURE IT IS ISOLATED FROM THE SYSTEM AND ALL REFRIGERANT IS REMOVED (PUMPED OUT TO ZERO PRESSURE).

REV	DESCRIPTION	SIGN	DATE
	HANSEN TECHNOLOGIES CORPORATION		
	MACHINING TOLERANCES UNLESS OTHERWISE SPECIFIED		
	TOLERANCES X/X" ± 1/64"		
	.XX ± .01		
	.XXX ± .005		
	CONCENTRICITY .005 T.I.R.		
	ANGULARITY ± 1/2°		
	.03 RADIUS UNLESS OTHERWISE SPECIFIED		
	FINISH 125 Ra OR BETTER		
	NO RUST, BURRS OR SHARP EDGES		
	TITLE	DRAWN BY	DATE
	M3Q ELECTRONIC ACTUATOR AND PILOT SPECIFICATIONS	K.R.	02-19-01
	SCALE	RELEASED BY	RELEASE DATE
	NONE		
	PART NO.	REV	
	7502-31	-	
REV	ECN NO.		

# TYPICAL WIRING & APPLICATIONS FOR ELECTRONIC ACTUATOR & PILOT WITH A350P CONTROLLER & 4-20 mA SIGNAL INPUT

**TABLE 2**  
**CONTROLLER TO ACTUATOR WIRING**  
**MINIMUM WIRE SIZE**

SHIELDED CABLE LENGTH		WIRE GAGE
FEET	(METERS)	
500	(152)	18 AWG
250	(76)	22 AWG
50	(15)	22*AWG

\* DOES NOT REQUIRE SHIELDED CABLE

**PARTS LIST**

ITEM	DESCRIPTION	QTY.	PART #
3	TEMPERATURE CONTROLLER A350P WITH TEMPERATURE SENSOR	1	75-0854
4	DIGITAL READOUT, D350	1	75-0855
5	TRANSFORMER, TR40 40 VA, 120VAC/230VAC : 24 VAC	1	75-0718

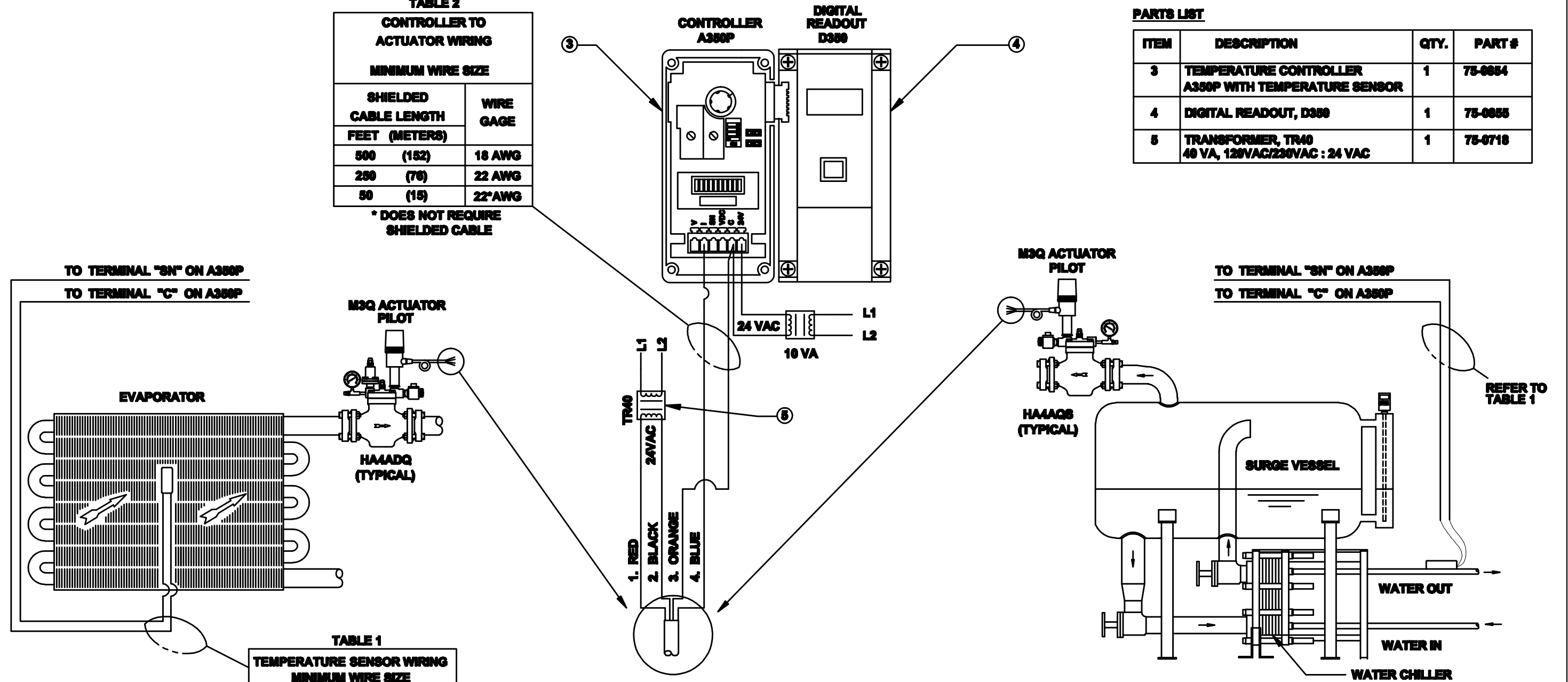

**TABLE 1**  
**TEMPERATURE SENSOR WIRING**  
**MINIMUM WIRE SIZE**

SHIELDED CABLE LENGTH		WIRE GAGE
FEET	(METERS)	
800	(244)	14 AWG
500	(152)	16 AWG
310	(94)	18 AWG
200	(60)	20 AWG
124	(38)	22 AWG
50	(15)	22*AWG

\* DOES NOT REQUIRE SHIELDED CABLE

NOTE: DRAWINGS ARE FOR ILLUSTRATION PURPOSES ONLY. NOT ALL COMPONENTS ARE SHOWN.

REV	DESCRIPTION	SIGN	DATE
<b>HANSEN TECHNOLOGIES CORPORATION</b>			
MACHINING TOLERANCES UNLESS OTHERWISE SPECIFIED TOLERANCES X/X <sup>±</sup> 1/64" XXX ±.005		TITLE <b>M3Q ACTUATOR PILOT TYPICAL APPLICATIONS</b>	
CONCENTRICITY .005 T.I.R. ANGULARITY: 1/2°		SCALE <b>NONE</b>	DRAWN BY <b>KR</b>
.05 RADIUS UNLESS OTHERWISE SPECIFIED		DATE <b>2-23-01</b>	
FINISH 125 Ra OR BETTER NO RUST, BURRS OR SHARP EDGES		MATERIAL <b>AS NOTED</b>	RELEASED BY <b>RELEASE DATE</b>
PART NO. <b>7502-32</b>			REV <b>-</b>
REV	ECN NO.		

## VA-720x Electric Valve Actuator

*The VA-720x Series synchronous motor-driven actuator provides incremental (three wire), incremental with feedback or proportional control of valves with up to 3/4 in. stroke in heating, ventilating, and air conditioning applications.*

*This compact, non-spring return actuator has a 180 lb force minimum and responds to a variety of input signals.*

*The VA-720x Series can be easily field mounted or ordered factory coupled to VBC Series bronze cage trim valves and VG7000 Series valves. Refer to the VBC and VG7000 Series bulletins for available configurations.*



Figure 1: VA-720x Electric Valve Actuator

Features and Benefits	
<input type="checkbox"/> <b>180 lb Force Output in a Compact Unit</b>	Covers a wide range of applications with one actuator
<input type="checkbox"/> <b>Magnetic Clutch</b>	Provides constant output force for positive closeoff of valves, and protects motor in stall conditions
<input type="checkbox"/> <b>Durable Construction</b>	Provides a longer cycle life
<input type="checkbox"/> <b>Unique Yoke Design</b>	Easy field mounting to valves reduces installation and stroke adjustment time
<input type="checkbox"/> <b>Selectable Direct/Reverse Action</b>	Eases setup and installation
<input type="checkbox"/> <b>Built-In Resistor for Current Input Control</b>	Provides greater application flexibility

## Operation

The VA-720x Series actuators use a reversible synchronous motor and a magnetic clutch to accurately position the valve. This combination can reliably generate 180 lb of force in either direction.

The actuator maintains the shutoff force even if power to the actuator is removed. When the controller provides a signal for the actuator to move in the opposite direction, the shutoff force is reduced and the valve modulates.

The magnetic clutch maintains a constant load at the end of travel, which ensures tight valve shutoff and compensates for seat wear.

### Incremental Control--VA-7200

A controller provides 24 VAC to the Up or Down, and Common terminals depending upon the desired movement of the valve stem. This signal causes the motor to rotate in the desired direction. The gear train and drive screw move the valve stem up or down. When the controller stops sending a signal, the valve stem is held in place and remains in position, until the next control signal is sent.

Note: In incremental applications, there is no direct correlation between valve position and controller output (0 to 100%). If correlation is important, use proportional control or actuators that provide position feedback.

### Feedback Control--VA-7203

VA-7203 actuator operation is the same as the VA-7200, while providing position feedback.

A 2k ohm position feedback potentiometer provides remote position indication to a controller. The 0 to 2k ohm feedback potentiometer is proportional to the full 3/4 in. actuator stroke and includes a field adjustable zero.

### Proportional Control--VA-7202

The VA-7202 provides a proportional stroke in relation to the input control signal of 0 to 10 VDC (maximum), with an adjustable starting point of 0 to 8 VDC and an adjustable span of 2 to 10 VDC. Current input may be jumper selected for 0 to 20 mA (maximum) with an adjustable starting point of 0 to 16 mA and an adjustable span of 4 to 20 mA. It also features stroke selection and Direct Acting (DA) or Reverse Acting (RA) jumpers.

An electronic controller provides the proportional input signal to the VA-7202. This signal is compared to the actual valve position via the internal feedback potentiometer.

The internal circuit activates the motor to rotate in the proper direction. The gear train and drive screw move the valve stem to the position called for by the input signal.

Note: The actuator will accept control signals of 20 VDC maximum with signals over 10 VDC ignored by the actuator.

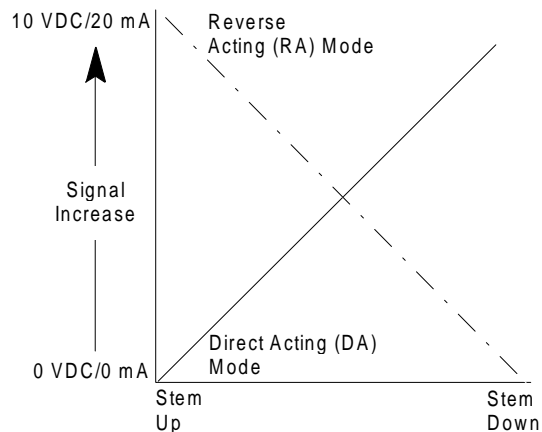

Figure 2: Direct/Reverse Action

## Dimensions

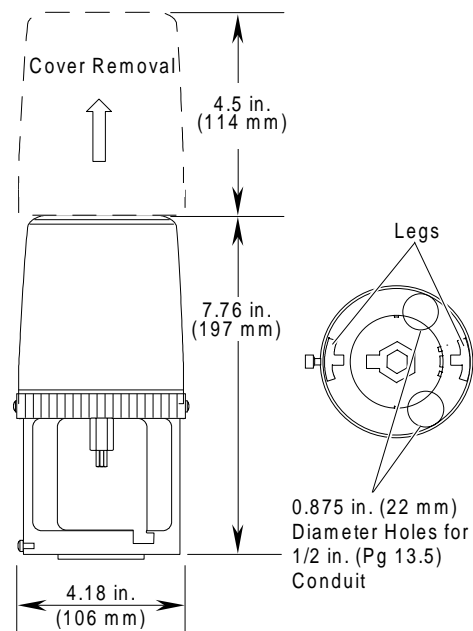
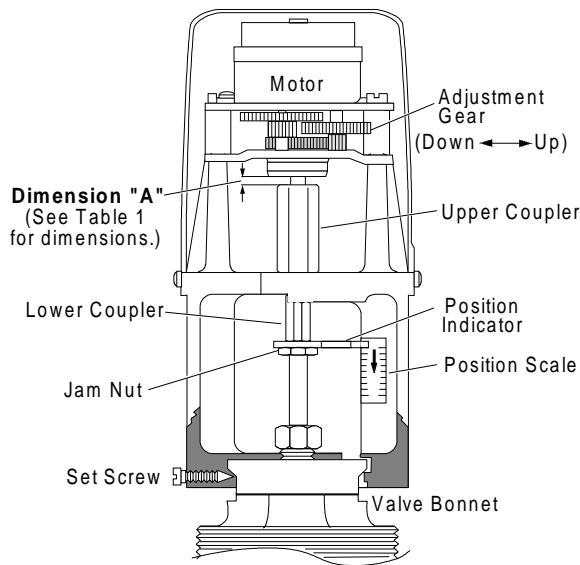

Figure 3: VA-720x Series Dimensions

# Installation



**Figure 4: Actuator Components**

## Kit Includes

- VA-720x Actuator
- jam nut
- position indicator
- two position scales

## Tools Required

- wrenches, 9/16 in. (14 mm) open end and small adjustable or 10 mm
- flat-blade screwdrivers, 3/32 and 1/4 in.
- Phillips screwdriver, No. 1

## Procedures

1. Unpack the actuator and remove its cover by loosening the two screws on the sides of the cover.
2. Visually verify **Dimension "A"** as shown in Figure 4. Use Table 1 to determine the proper gap measurement. If required, manually turn the adjustment gear between the metal plates to achieve the correct gap.



**CAUTION: Equipment Damage Hazard.**  
To avoid equipment damage the VA-720x must **not** be used with the slotted stem 1/2 in. VT Series valve.  
To avoid increased seat wear, which leads to reduced operating life, use with a 1/2 in. valve is **not** recommended.

**Table 1: Dimension "A" Gap Reference**

Valve Model	Valve Size	Valve Stroke	Dimension "A"
<b>VBC/ Cage Trim</b>	3/4 in.	1/2 in. (13 mm)	5/64 in. (2 mm)
	1 to 2 in.	3/4 in. (19 mm)	5/64 in. (2 mm)
<b>VG7000</b>	1/2 to 3/4 in.	5/16 in. (8 mm)	5/64 in. (2 mm)
	1 to 1-1/4 in.	1/2 in. (13 mm)	5/64 in. (2 mm)
	1-1/2 to 2 in.	3/4 in. (19 mm)	5/64 in. (2 mm)
<b>Honeywell* V50xxx</b>	1/2 to 3 in.	3/4 in. (19 mm)	5/64 in. (2 mm)
<b>Siebe* (Barber- Colman) VB-9xxx</b>	1/2 in.	3/8 in. (9.5 mm)	5/64 in. (2 mm)
	to 1-1/4 in.	1/2 in. (13 mm)	5/64 in. (2 mm)

\* Requires the mounting kit listed in the *Accessories* table.

Note: Turning the gearing Clockwise (CW) will increase the gap dimension. It is necessary to manually turn the gearing several times before you see movement of the drive screw and the coupler.

3. Thread the jam nut down to the end of the valve stem thread.
4. Place the position indicator on top of the jam nut as shown in Figure 5.

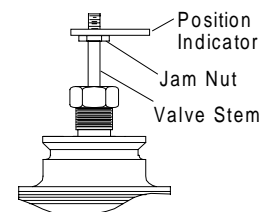

**Figure 5: Installing Nut and Position Indicator**

5. Push valve stem into its full down position.
6. Position the actuator on the valve bonnet, making sure the notch in the position indicator is captured by the actuator yoke.

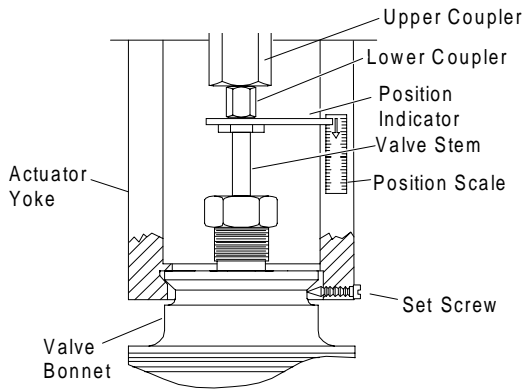

**Figure 6: Installing the Valve Actuator**

7. Use a 1/4 in. flat-blade screwdriver to tighten the set screw.
8. Lift the stem to meet the coupler and tighten the coupler fully onto the stem.
9. Using a small adjustable wrench and a 9/16 in. open end wrench, tighten the coupler and jam nut an additional 1/8 to 1/4 turn.
10. Attach the position scale label to the actuator yoke as shown in Figure 6. Place the second label on the backside of yoke.
11. Insert the wires through the bushing in the actuator yoke and connect to the actuator using the appropriate wiring diagrams. (See *Wiring* section.)
12. Provide the control signal to drive the actuator up and down at least two complete cycles to check for proper operation.
13. Verify that the actuator is fully stroking the valve in the full down position and that clearance (Step 2) is maintained in the full up position.

**Note:** If the valve is not fully seating in the down position, decrease gap Dimension “A” by reducing the thread coupler engagement. Gap must be sufficient to allow the actuator to stall at the end of stroke.

14. Proceed with adjustments in the *Adjustments* section if required. Otherwise, replace the cover and tighten the cover screws.

**Note:** If adjustments are required, refer to the following:

- VA-7202: *Adjustments* section
- VA-7203: *Adjustments* section

## Wiring



**WARNING: Equipment Damage Hazard.** Disconnect the power supply before wiring connections are made to prevent possible damage to the equipment. Make and check all wiring connections before applying power to the system. Short-circuited or improperly connected wires may result in permanent damage to the unit.

All wiring must be in accordance with applicable electrical code requirements. Input lines to the actuator must be wired correctly for the valve to move in the proper direction.

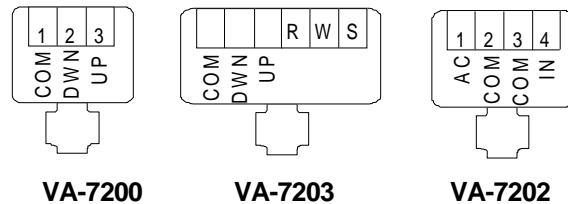

**Figure 7: Application and Drawing Identification**

**Note:** Follow wiring and termination instructions detailed in the applicable controller manual.

### Incremental Control—VA-7200

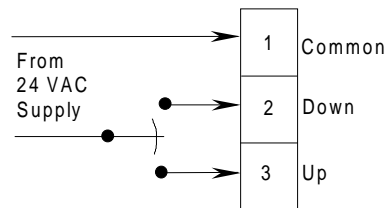

**Figure 8: Basic Incremental Wiring**

**Table 2: VA-7200 Action**

Energizing Terminals	Actuator Coupler
1-2	Extends
1-3	Retracts

Incremental control wiring should be connected to Terminals: (1) Common, (2) Down, and (3) Up. Providing power to Terminals 1 and 2 will cause the actuator coupler to extend, pushing the valve stem down. Providing power to Terminals 1 and 3 will cause the actuator coupler to retract, pulling the valve stem up.

## Incremental Control with Feedback--VA-7203

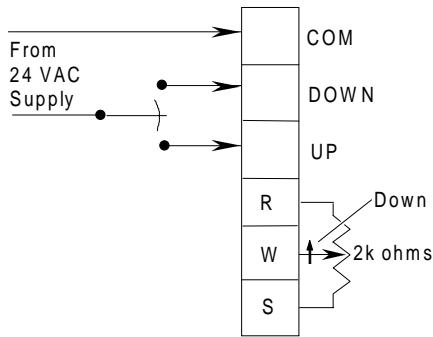

Figure 9: Basic Feedback Wiring

Table 3: VA-7203 Resistance Change

Actuator Coupler	Feedback Resistance Change	
	R - W	W - S
Extends	Decrease	Increase
Retracts	Increase	Decrease

The position feedback potentiometer is connected to Terminals R, W, and S. Terminals R and S have a fixed 2000 ohms resistance. The potentiometer wiper is connected to Terminal W. Resistance change vs. actuator travel is shown in Figure 10.

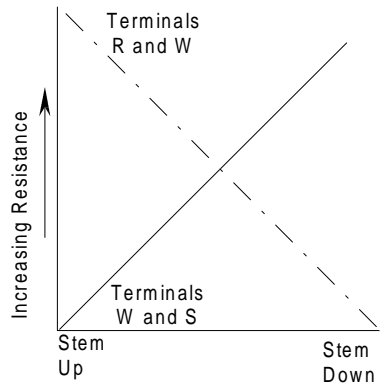

Figure 10: Feedback Resistance

## Proportional Control--VA-7202

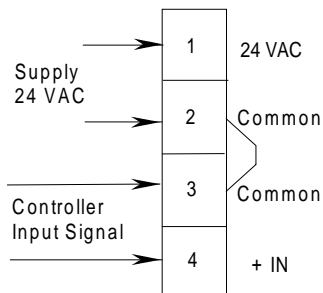

Figure 11: Basic Proportional Wiring

Note: Terminals 2 and 3 are tied together on the circuit board.

Table 4: VA-7202 Action

Input Signal	Actuator Coupler	
	DA	RA
Increase	Extends	Retracts
Decrease	Retracts	Extends

Voltage supply wiring should be connected to Terminals (1) AC and (2) Common. Control wiring is to Terminals (3) Common (-) and (4) IN (+).

With a low control signal voltage applied across Terminals 3 and 4, the actuator coupler will be fully retracted in Direct Acting (DA) mode, and fully extended in Reverse Acting (RA) mode. With a high control signal voltage applied across Terminals 3 and 4, the actuator coupler will be fully extended in Direct Acting (DA) mode, and fully retracted in Reverse Acting (RA) mode.

In Direct Acting (DA) mode, an increasing signal will cause the actuator coupler to extend, pushing the valve stem down. A decreasing signal will cause the actuator coupler to retract, pulling the valve stem up.

In Reverse Acting (RA) mode, a decreasing signal will cause the actuator coupler to extend, pushing the valve stem down. An increasing signal will cause the actuator coupler to retract, pulling the valve stem up (See Figure 2).

## Adjustments

### Feedback Control--VA-7203

#### Adjusting Feedback Resistance

With the actuator retracted (valve stem fully up), the actuator is factory calibrated for 100 ohms maximum across Terminals W-S.

Note: Feedback requirements may vary depending upon the application and controller calibration.

For example, to calibrate the actuator for 1000 ohms at mid-stroke (50% of travel):

1. Drive the actuator so the valve stem is in the full up position.
2. Use an ohmmeter to measure the resistance between Terminals W and S. Resistance should be between 0 and 100 ohms; use this value (R1) in the formula found in Step 7.
3. If resistance is greater than 100 ohms, loosen the locking screw (accessible through the access hole in the actuator yoke in Figure 12).

- Using a 3/32 in. flat-blade screwdriver, turn the adjustment screw so that the ohmmeter reading is less than 100 ohms.

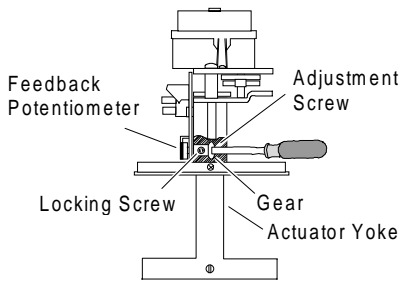

**Figure 12: VA-7203 Feedback**

- Retighten locking screw, and drive the actuator so the valve stem is in the full down position.
- Measure the resistance between Terminals W and S with the ohmmeter. Use this value (R2) in the formula found in Step 7.
- Drive the actuator to the full up position.
- Loosen the locking screw, and turn the adjustment screw so the ohmmeter reads the value determined by the following formula:

$$1000 - [(R2 - R1) / 2] = \text{Full up resistance}$$



**CAUTION: Equipment Damage Hazard.**

Measure the resistance between Terminal R and S. Damage to the potentiometer may occur if  $1000 + [(R2 - R1) / 2]$  is greater than the measured resistance of R and S. Reduce the mid-stroke resistance below 1000 ohms to prevent damage.

- Retighten the locking screw.
- Verify operation by driving the actuator until resistance reads 1000 ohms on the ohmmeter. Note the position using the position indicator and scale. The actuator should be approximately at mid stroke and calibrated for 1000 ohms at mid stroke (50% of travel).
- Replace the cover and secure with the screws. The unit is ready for operation.

**Proportional Control--VA-7202**

**VA-7202 Factory Settings:**

- Direct acting
- 1 to 9 VDC  $\pm 0.5$  VDC for use with 0 to 10 VDC controller and 3/4 in. stroke Push Down to Close (PDTTC) applications.

- Signal fail position jumper is in full up position.

Note: The actuator will accept control signals of 20 VDC maximum with signals over 10 VDC ignored by the actuator. If factory settings need to be changed, verify actuator calibration.

**Calibration**

- Set the stroke jumper to approximate the stroke of the valve. See Figure 13 for jumper location.

- Jumper 8: 5/16 in. or 8 mm
- Jumper 10: 3/8 in. or 10 mm
- Jumper 13: 1/2 in. or 13 mm
- Jumper 19: 3/4 in. or 19 mm

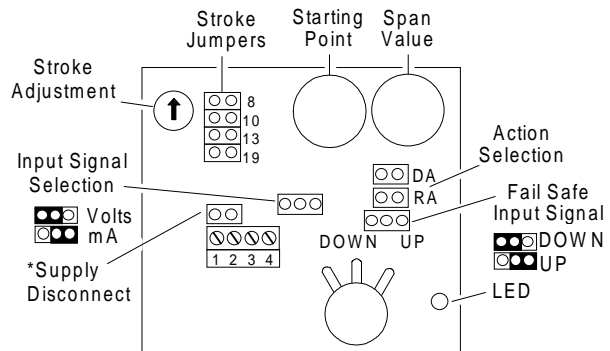

\* Disconnects power supply to the circuit. Must be in place for actuator operation.

**Figure 13: VA-7202 Components**

- Set the direct/reverse action jumper so that the valve stem travels in the desired direction (per changes in control signal).
  - DA (top jumper) = stroke down on signal increase
  - RA (bottom jumper) = stroke up on signal increase
- Set the input signal selection jumper for voltage input or current (mA) input to match the controller output; see Figure 13. (If the input signal selection jumper is removed, the actuator defaults to voltage input.)

Note: If mA input is selected, multiply the start and span scales by two.

- Set the signal fail position jumper to select default position of fully up or fully down. If the signal is lost at the actuator (open connection), the actuator will default to the pre-designated position of full up or full down.

Note: If mA input is selected, the actuator will default to the low input signal position.

5. Adjust the potentiometers to the nominal values. Set the stroke adjustment to the midpoint as shown in Figure 13. Set the starting point (offset) to the low input signal using the scale printed on the circuit board as a reference. Set the span value to the high input signal minus the offset; see Table 5 in Step 6. Use the scales for reference.
6. Apply voltage specified by application (RA/DA) requirements to drive the actuator to the full up position using the following table. (If mA input is selected, multiply all values by 2.)

**Table 5: VA-7202 Calibration Values**

Application Values		Calibration Values	
Minimum	Maximum	Minimum	Maximum
0	10	1	9
0	5	1	4
5	10	6	9

Note: Use of the calibration values ( $\pm 5V$ ) found in Table 5, will ensure proper shutoff throughout the life of the valve (accounts for seat wear).

If the application requires values other than those given, use the **minimum application value + 1V** and the **maximum application value - 1V** to determine calibration values.

- DA: full up (minimum voltage)
- RA: full up (maximum voltage)

As actuator is driving, the LED will be on.

7. Slowly turn the starting point potentiometer (shown in Figure 13) CW until the valve stem reaches the end of stroke to ensure that the valve stem is in the full up position. (LED will be on; there should be no gear movement.)
8. Slowly turn the starting point potentiometer counterclockwise (CCW); stop when the LED flashes or goes out.  
  
If the LED does not flash or go out, verify Dimension "A" (Table 1). Excessive gap may not allow full up calibration. To decrease gap Dimension "A" to meet Table 1 requirements, reduce the thread coupler engagement, then repeat Steps 7 and 8.  
  
Note: The actuator circuit contains a time out feature. If calibration takes longer than 3-10 minutes, the LED will go out giving a false satisfied condition. If this occurs, cycle the power to the actuator and readjust the starting point.
9. Apply the input voltage specified by application (RA/DA) requirements to drive the valve stem to the full down position per chart in Step 6.

10. To ensure that the valve stem is in the full down position, slowly turn the stroke potentiometer CW until the valve stem reaches the end of stroke. (LED will be on, and there should be no gear movement.)
11. Slowly turn the stroke potentiometer CCW until the LED goes off.
12. If the full down position can not be reached, return the stroke potentiometer to the nominal position and slowly turn the span potentiometer CCW until full down is reached. Repeat Step 11.
13. Adjust voltage to drive the actuator to the full up position. Verify starting point adjustment.
14. Check for proper operation using the desired minimum and maximum operating voltages. Allow the actuator to operate through several complete cycles.

Note: The LED will remain on for 3-10 minutes after the actuator has completed operation cycle.

15. Replace the cover and secure with the screws. The unit is ready for operation.

## Repair Information

Field repairs must not be made. For a replacement actuator, contact the nearest Johnson Controls representative.

## Ordering Information

To order a VA-720x Series Electric Actuator, contact your local Johnson Controls representative and specify the complete product code number:

**Table 6: Products Available**

Code Number	Description
VA-7200-1001	Three Wire Incremental
VA-7203-1001	Three Wire incremental with Position Feedback
VA-7202-1001	Proportional, 0 to 10 VDC, 0 to 20 mA

**Table 7: Accessories**

Code Number	Description
V-9999-BC1	Bonnet Adaptor used for field mounting to 1/2 to 1-1/4 in. VB-9xxx Series Siebe (Barber-Colman) valves
V-9999-HW1	Bonnet Adaptor used for field mounting to V5011 A, F, G 1/2 to 3 in. single-seated and V5013F three way Honeywell® valves.

# Specifications

<b>Product</b>	VA-7200: Three wire incremental VA-7203: Three wire incremental with position feedback VA-7202: Proportional, 0 to 10 VDC/ 0 to 20 mA
<b>Power Requirements</b>	24 VAC (20 to 30 VAC), 50/60 Hz VA-7200: 6.7 VA Nominal VA-7203: 6.7 VA Nominal VA-7202: 8.7 VA Nominal
<b>Input Signal</b>	Incremental: 24 VAC, 50/60 Hz Proportional: 0 to 10 VDC or 0 to 20 mA (jumper selectable)
<b>Input Signal Adjustments (Proportional)</b>	Input Signal: VDC or mA (jumper selectable) Offset: 0 to 8 VDC/0 to 16 mA Span: 2 to 10 VDC/4 to 20 mA Action: Drive up (DA) or drive down (RA) on signal increase (jumper selectable) Factory Setting: Calibrated 1 to 9 ± 0.5 VDC for 0 to 10 VDC controller operation, Direct Acting (DA), 3/4 in. (19 mm) stroke
<b>Input Impedance (Proportional)</b>	Voltage: 100k ohms Current: 500 ohms
<b>Feedback Signal</b>	VA-7203: 0 to 2k ohms ±20% for 25/32 in. (20 mm) stroke, 1/4 watt
<b>Mechanical Output</b>	180 lb force (800 N) minimum
<b>Stroke Range</b>	25/32 in. (20 mm) maximum
<b>Nominal Stroke Timing</b>	60 Hz: 26 seconds for 5/32 in. (8 mm) stroke 42 seconds for 1/2 in. (13 mm) stroke 62 seconds for 3/4 in. (19 mm) stroke 50 Hz: 32 Seconds for 5/32 in. (8 mm) stroke 50 seconds for 1/2 in. (13 mm) stroke 74 seconds for 3/4 in. (19 mm) stroke
<b>Electrical Connections</b>	Screw Terminals: VA-7200: 24 to 14 AWG VA-7203: 24 to 16 AWG VA-7202: 24 to 16 AWG
<b>Mechanical Connections</b>	1/4-28 UNF-2B thread for valve stem connection
<b>Enclosure</b>	NEMA 2, IP42
<b>Ambient Operating Conditions</b>	23 to 131°F (-5 to 55°C), 10 to 90% RH, non-condensing, 86°F (30°C) maximum dew point
<b>Ambient Storage Conditions</b>	-4 to 150°F (-20 to 65°C), 5 to 95% RH, 86°F (30°C) maximum dew point
<b>Dimensions</b>	4.18 in. diameter x 7.76 in. high (106.3 x 197.2 mm)
<b>Shipping Weight</b>	2.2 lb (1.0 kg)
<b>Agency Compliance</b>	UL 873 Listed, File E27734, Guide XAPX, Class 2 operation, plenum rated CSA C22.2 No. 139 Certified, File LR85083, Class 3221 01, Class 2 operation CE Directive 89/336/EEC

The performance specifications are nominal and conform to acceptable industry standards. For application at conditions beyond these specifications, consult the local Johnson Controls office. Johnson Controls, Inc. shall not be liable for damages resulting from misapplication or misuse of its products.



**Controls Group**  
507 E. Michigan Street  
P.O. Box 423  
Milwaukee, WI 53201

Printed in U.S.A.