

HANSEN TECHNOLOGIES CORPORATION

Refrigerant Float Switches For Ammonia, R-12, R-22, R-502 And Similar Liquids

FUNCTION

The Hansen refrigerant liquid level float switch (HLL Series) is used to electrically indicate or control a liquid level by opening and closing a SPDT switch. It may be used to control a liquid level by electrically opening and closing a liquid feed solenoid valve or similar device. It may also serve as a high or low level alarm or cutout. A standard 2" differential prevents the switch from "short cycling" due to fluctuations of the liquid level; closer differentials are available to 1/2".

FEATURES

Rugged 10 Ampere switching capacity eliminates most switch burnouts due to overloads.

Springs at top and bottom of float chamber prevent float ball damage caused by gas surges.

High strength larger diameter ball stem eliminates potential stem bending or breakage.

Simple, direct, switch pivot-arm overcomes potential mechanical failure.

Hermetic Switch housing assembly with optional metal cover.

Optional switch housing heater for applications below -20° F.

Switch Assembly and/or tank assembly are interchangeable with the R/S LL series float switches.

SPECIFICATIONS

Safe Working Pressure:
400 PSIG

Operating Temperature:
-50° F to +150° F

Connections:
3/4 FPT/1" Butt Weld combination.

HANSEN TECHNOLOGIES CORPORATION

129 West 83rd Street
Burr Ridge, Illinois 60521 U.S.A.
Telephone: (312) 325-1565
Outside IL: 1-800-426-7368

Telex:
206851

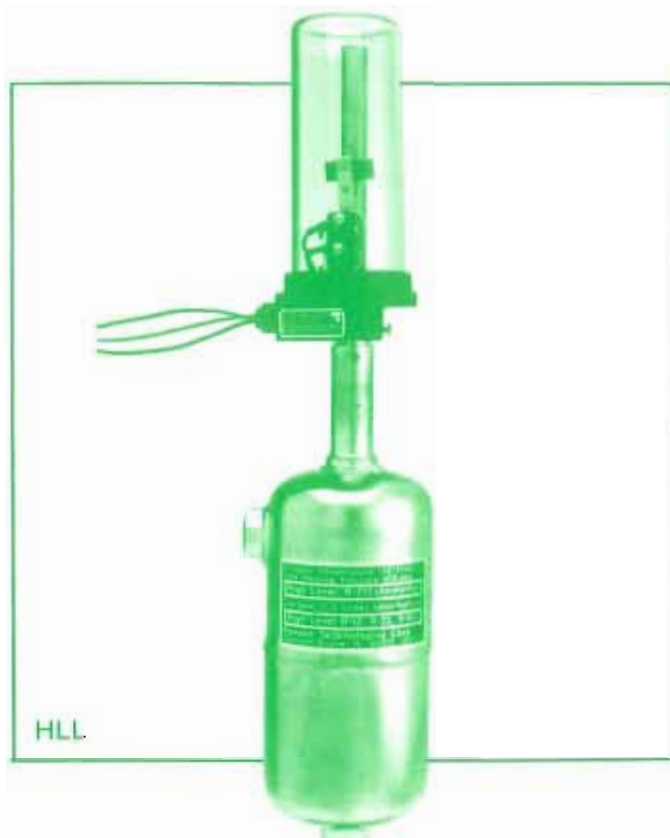

ADVANTAGES

The HLL switch incorporates several design improvements and features to eliminate shortcomings associated with other refrigerant float switches. A larger, 10 amp switch overcomes the most common cause of switch failure: overload due to improper wiring during installation or solenoid coil burnout during operation. In either case, an HLL float switch installed on a 15 amp breaker circuit can withstand the occasional overload without failure. Also, springs located at the top and bottom of the float chamber protect the float ball from damage during float chamber pressure surges.

Ordering Information		
Cat. No.	Description	Weight
HLL	Standard Hermetic Float Switch with side and bottom connection	12 lbs
HLLS	Universal Hermetic Float Switch with 2-side and 1 bottom connection	13 lbs
HLLC	HLL with protective metal cover	13 lbs
HLLSC	HLLS with protective metal cover	14 lbs
HLLSW	Switch Assembly only (fits all HLL & R/S LL Float Switches)	2 lbs
COV	Metal cover only (fits all HLL)	1 lb
HTR1*	10 Watt 115V Heater (fits all HLL)	1 lb
HTR2*	10 Watt 230V Heater (fits all HLL)	1 lb

*To order Float Switch with heater, add H Suffix, Example: HLLH

Refrigerant Float Switch

FEATURES

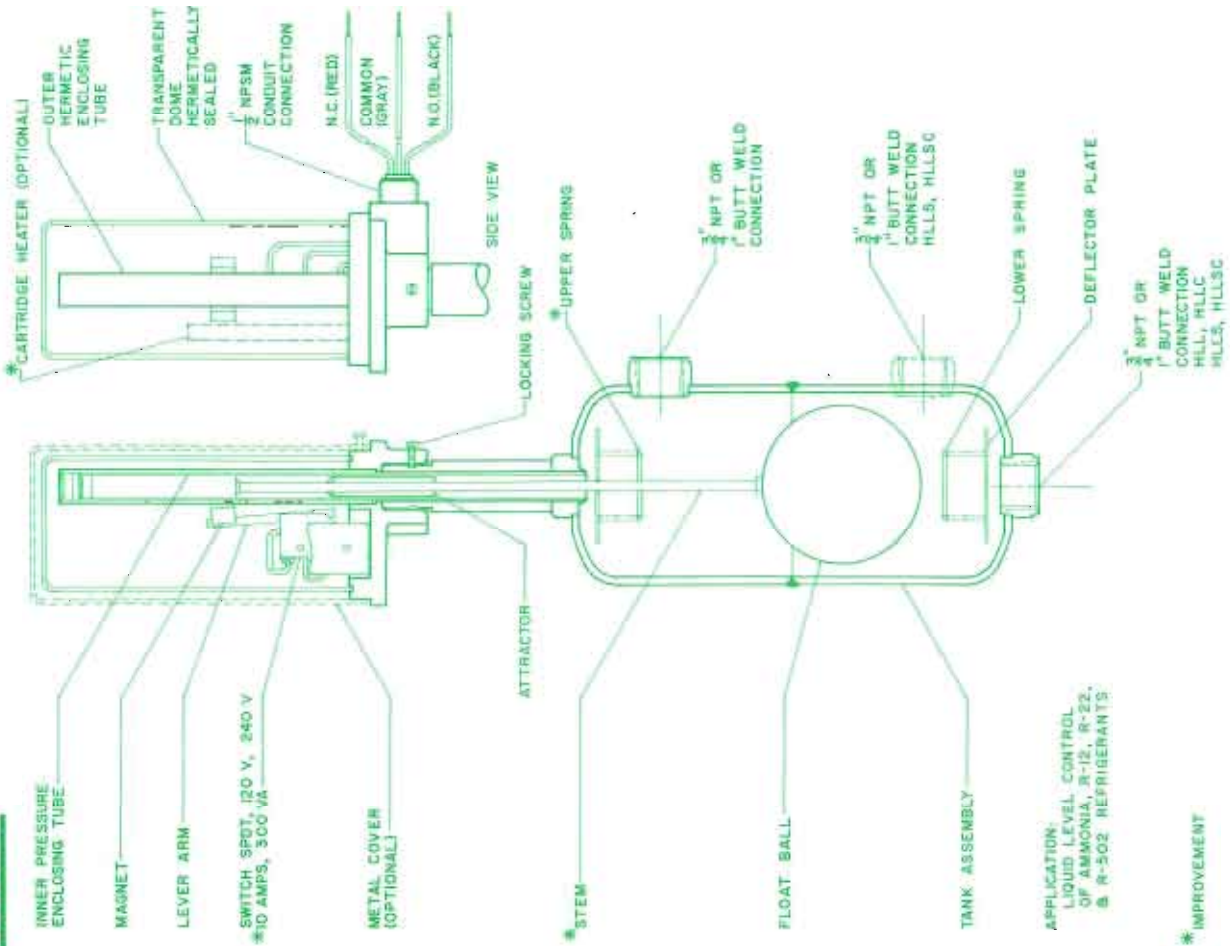

DIMENSIONS (INCHES)

