

## HANSEN TECHNOLOGIES CORPORATION



PROBE WITH CONTROL UNIT

### INTRODUCTION

Due to the increasing cost of refrigerants and the existing pending governmental regulations concerning the escape, leakage and replenishment of refrigerants, more accurate and sophisticated methods are needed to conserve and track refrigerant usage. These level transducer probes and control units facilitate the continuous accurate measurement of refrigerant liquid levels. From this information all of the following results can be achieved: refrigerant loss detection, refrigerant inventory measurements, warnings of excess refrigerant levels, insufficient refrigerant quantity and other information available as a result of receiver liquid level monitors.

These probes and control units are particularly well suited for application in commercial/supermarket refrigeration systems without computers. SHP and SVP models are available for isolated 0-5 volt D.C. output only, contact Hansen for details.

### APPLICATIONS

Low voltage  
High level alarm/cut-out  
Low level alarm/cut-out  
Level monitoring  
Refrigerant inventory

### Specifications, Applications, Service Instructions & Parts

### "LEVEL CAT" REFRIGERANT LEVEL TRANSDUCER PROBE WITH CONTROL UNIT

for horizontal and  
vertical receivers

### KEY FEATURES

Easy to read digital readout  
Two SPDT 10 amp relays  
Full length receiver level monitoring  
Very compact size  
Operates on line voltage  
Probes have no moving parts  
Custom lengths available  
Suitable for R12, R22, R134a, and  
other approved refrigerants

### ORDERING INFORMATION, LEVEL TRANSDUCER PROBES WITH CONTROL UNITS

CAT. NO.	DESCRIPTION
<b>SHC</b>	<b>For Horizontal Receivers</b>
SHC06	6" Insertion Length
SHC08	8" Insertion Length
SHC12	12" Insertion Length
SHC16	16" Insertion Length
SHC20	20" Insertion Length
SHC24	24" Insertion Length
SHCxx	Custom Insertion Length
<b>SVC</b>	<b>For Vertical Receivers</b>
SVC36	36" Insertion Length
SVC48	48" Insertion Length
SVC60	60" Insertion Length
SVCxx	Custom Insertion Length

**TO ORDER:** Specify Catalog Number, Insertion Length, Refrigerant, Voltage, whether for a vertical or horizontal receiver, Receiver Diameter, and Custom Insertion Length if desired. (Insertion length is measured from the bottom of probe to the first thread on probe body.)

## MATERIAL SPECIFICATIONS

### CONTROL UNIT

Enclosure: 6 1/4" W X 4 1/4" H X 4 3/4" D; Splashproof

Power: 110-120V/50/60Hz Standard  
220-240V/50/60Hz Optional

Display: Two digit L.E.D. display, 1/2" characters

Outputs: Two SPDT 10 ampere relays

0 to 5 volt D.C. (non-isolated)

proportional to liquid level

Linearity: Typically ±2% of actual

Terminal Strip: Accepts 14-22 AWG wire sizes

Ambient Temperature Range: 50F to 125F

### PROBE

Fitting: 3/4" MPT, plated steel

Probe Rod: Stainless steel, teflon enclosed

Shielding Tube: Stainless steel (horizontal probes)

Standard Probe Insertion Lengths:

Horizontal: 6", 8", 12", 16", 20", 24" (nominal)

Vertical: 36", 48", 60" (receivers up to 20" dia.)

(Special lengths to order)

Operating Temperature: -50F to 240F

Safe Working Pressure: 400 psig

Probe Cable Length: 36" fixed length, coaxial

## ADVANTAGES

These level transducer probes come factory pre-calibrated and tested. There are no moving parts on the probe to break, jam or fail. Simple 3/4" NPT probe-to-receiver fitting. These probes and control units have been specifically designed to monitor the liquid level in refrigerant receivers. They provide a digital display of liquid level percentage. The digital display permits quick reading of liquid level. The "Anti-Splash" dampening feature ignores normal turbulence in the receiver to facilitate more accurate liquid level readings and prevent most "false alarms" and shut-downs.

The two SPDT 10 ampere relays enable alarms, cut-outs, and solenoid valves, etc. to react when changes in liquid levels occur. Also, a non-isolated 0 to 5 volt D.C. output signal is provided which is proportional to liquid level. However, the main usage and intent of the Level Cat is to provide adjustable level switches rather than a refined level proportional electronic output.

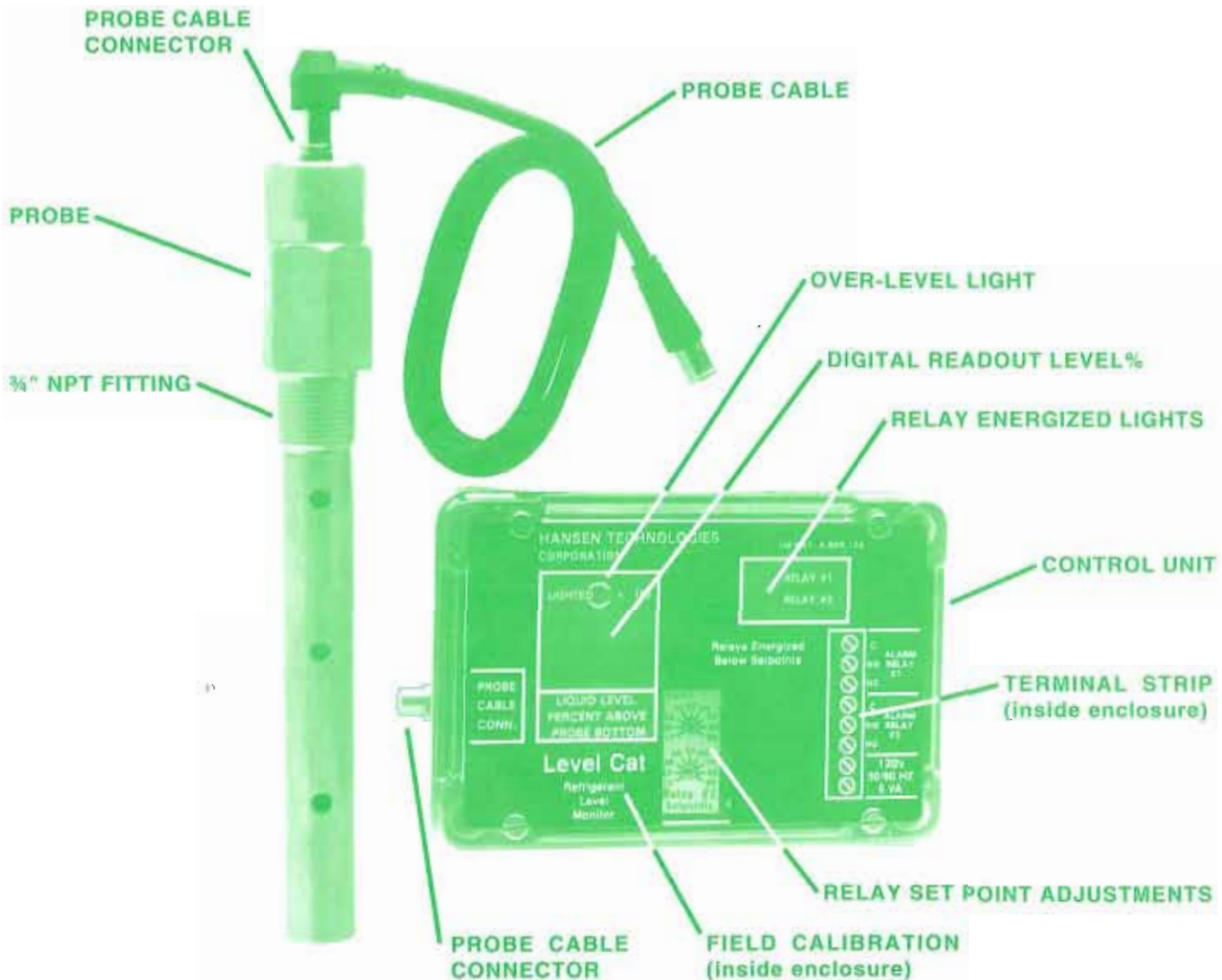

## INSTALLATION

Carefully remove probe from its carton. When installing receiver probes, adequate clearance should be provided above the  $\frac{3}{4}$ " FPT fitting on the receiver to ensure the installation and removal of probes without bending. Use proper sealant on  $\frac{3}{4}$ " MPT fitting on probe and insert the probe into the receiver fitting opening on the zero pressure receiver. There should be adequate clearance between the probe and the bottom of the receiver (approximately  $\frac{1}{2}$ "). Tighten probe on hex. Carefully test for leaks before returning to service.

These probes are not normally intended for evaporators or vessels containing bubbling liquid. Other models are available for such applications.

Mount control unit in a solid location within 36" from probe. Allow space on sides of the control unit enclosure to permit the connection of the probe cable and other electrical connections.

Use the factory supplied 36" probe cable. Do not modify or use any other cable than the one provided. Connect the angle end of the probe cable to the probe cable connector and the straight end to the external probe cable connector on the control unit. Probe cable can be installed opposite of above to suit installation.

## ELECTRICAL

The two SPDT (Single Pole Double Throw), 10 ampere relays, are suitable for voltages up to 250 VAC. Connect relay wiring at the internal terminal strip of the control unit. Note the logic of the relays: relays are energized when level is below set points.

The control unit requires an input power supply of 110-120V/50/60Hz standard (220-240V/50/60Hz optional). Note the voltage on the control unit nameplate and check the power supply at the wire leads to be sure that they are the same before connecting.

A non-isolated 0 to 5 volt D.C. output is standard with control unit; however, its use is optional. The two spade terminal located inside the control unit will supply a D.C. voltage signal proportional to liquid level. As with all non-isolated outputs, this output requires special precautions to prevent electrical noise and ground loops from entering circuit. Use best common practice when using this circuit.

## DIGITAL READOUT

The control unit has a bright, L.E.D. digital readout which displays percentage of liquid immersed probe length from 00% thru 99%. Above 99%, the readout is blank and the over-level light is lit; below 00%, the readout simply remains at 00%.

## PROBE INSTALLATION DIMENSIONS

For horizontal receivers

For vertical receivers

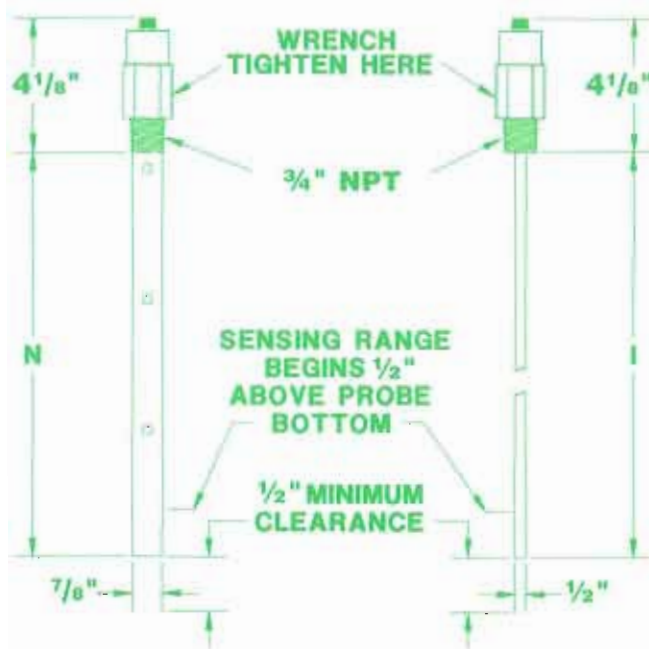

For Horizontal Receivers	
Nom. Insertion Length	Actual Length (N)
6"	6"
8"	8"
12"	12"
16"	15 $\frac{1}{4}$ "
20"	19 $\frac{7}{16}$ "
24"	23 $\frac{1}{16}$ "
For Vertical Receivers	
Insertion Length	Actual Length (I)
36"	36"
48"	48"
60"	60"

## RELAY SET POINTS

Each relay set point adjustment is a rotary dial located inside the control unit enclosure. The two rotary dials are labeled Relay #1 and Relay #2. The percentage values on the face of the dials relate to the liquid level in the receiver between the 10% level point and the 90% level point of the total probe insertion length.

Each set point has a 4% ( $\pm 1\%$ ) differential above the set point. The relays will energize at the set point on a falling level and will not de-energize until the level rises 4% (differential) above set point. This differential generally avoids short cycling and false alarms due to brief surges in liquid level. Two bright red lights visible through the enclosure cover, labeled "RELAY #1" and "RELAY #2", indicate when the respective relays are energized.

## RECALIBRATION INSTRUCTIONS

These transducer probes are normally factory pre-calibrated for the specified receivers with the specified refrigerant. Probes should not require any field adjustment in calibration settings. To calibrate when necessary remove printed enclosure cover with liquid level below the probe, adjust Z (zero) tiny brass calibration screw in left hand, blue rectangular potentiometer until digital readout shows 01%. Then establish a known level of liquid between 50% and 90%. Adjust S (span) tiny brass calibration screw in right hand blue potentiometer until digital readout shows the known level between 50% and 90%. If one determines that transducer probe cannot be satisfactorily calibrated or that refrigerant is other than that specified on control unit, contact factory for detailed calibration instructions.

## PRINCIPLES OF OPERATION

These probes are capacitance type level transducers. Capacitance is an electrical measurement which commonly is used to indicate an object's potential to store electricity. These objects usually consist of two electrodes with a medium separating them.

With these level transducer probes, the teflon enclosed stainless steel probe rod acts as one electrode, the receiver wall (vertical receiver probes) or the stainless steel perforated shielding tube (horizontal receiver probes) acts as the other, and separating them is the refrigerant liquid and vapor. Because the potential to store electricity is far greater for the refrigerant liquid than that of the vapor, the capacitance measurement of a probe in a receiver changes nearly proportionally with the refrigerant liquid level. With this information, the electronics can calculate the percentage of the probe which is immersed in liquid refrigerant and supply an appropriate signal output.

## SAFE OPERATION

These transducer probes and control units have been designed specifically for refrigeration systems. These instructions and related safety precautions must be completely read and understood before selecting, using or servicing these controls. Only knowledgeable, trained refrigeration mechanics should install, operate or service these controls. Stated temperature and pressure limits should not be exceeded. Probes should not be removed from receiver unless system has been evacuated to zero pressure.

**WARNING:** As with all electronic and mechanical components, there is a limited life expectancy. An expected life of seven to ten years is typical. This should be understood as only a suggested replacement time period. Actual condition and performance of electronics due to ambient conditions, quality of electrical current, voltage, etc. may necessitate a different replacement schedule. Regardless, probes and control units should be inspected and tested at least annually to insure their safe and continuous service. See also Safety Precautions in current List Price Bulletin and Safety Precaution Sheet supplied with product.

## WARRANTY

Hansen electronics are guaranteed against defective materials or workmanship for 90 days F.O.B. factory. All other components are guaranteed for one year F.O.B. factory. No consequential damages or field labor is included.

## TYPICAL WIRING DIAGRAM

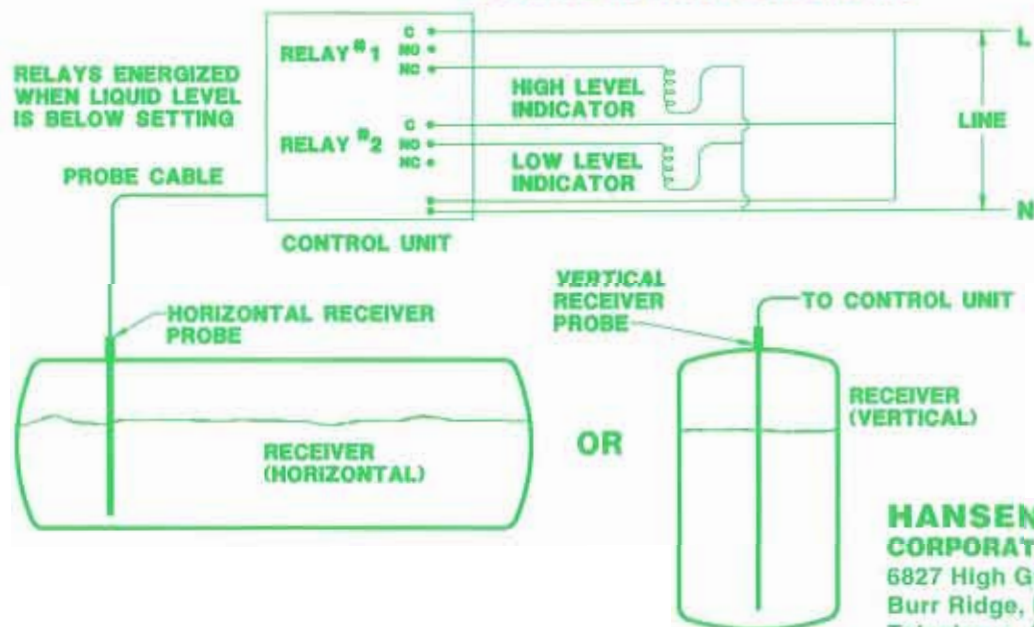

## HANSEN TECHNOLOGIES CORPORATION

6827 High Grove Boulevard  
Burr Ridge, Illinois 60521 U.S.A.  
Telephone: (708) 325-1565  
Outside IL: 1-800-426-7368  
FAX: (708) 325-1572