

HANSEN TECHNOLOGIES CORPORATION



Probe with Control Unit

INTRODUCTION

Due to the increasing cost of refrigerants and the existing pending governmental regulations concerning the escape, leakage and replenishment of refrigerants, more accurate and sophisticated methods are needed to conserve and track refrigerant usage. These level transducer probes and control units facilitate the continuous accurate measurement of refrigerant liquid levels. From this information all of the following results can be achieved: refrigerant loss detection, refrigerant inventory measurements, warnings of excess refrigerant levels, insufficient refrigerant quantity and other information available as a result of receiver liquid level monitors.

These probes and control units are particularly well suited for application in commercial/supermarket refrigeration systems without computers. SHP and SVP models are also available for isolated 0-5 volt (or 1 to 6 volt) D.C. output only; contact Hansen.

KEY FEATURES

- Easy to read bright digital readout
- Two SPDT 10 amp relays (adjustable levels)
- Full length receiver level monitoring
- Very compact size
- Operates on line voltage
- Probes have no moving parts
- Custom lengths available
- Suitable for R22, R134a, and other approved refrigerants

Specifications, Applications, Service Instructions & Parts

LEVEL CAT® REFRIGERANT LEVEL TRANSDUCER PROBE WITH CONTROL UNIT

S Series
for horizontal and
vertical receivers



APPLICATIONS

- High level alarm/cut-out
- Low level alarm/cut-out
- Level monitoring
- Refrigerant inventory

ORDERING INFORMATION, LEVEL TRANSDUCER PROBES WITH CONTROL UNITS

CAT. NO.	DESCRIPTION		
SHC	For Horizontal Receivers		
SHC06	6"	(152 mm)	Insertion Length
SHC08	8"	(203 mm)	Insertion Length
SHC12	12"	(305 mm)	Insertion Length
SHC16	15.3"	(387 mm)	Insertion Length
SHC20	19.2"	(487 mm)	Insertion Length
SHC24	23.1"	(586 mm)	Insertion Length
SHCxx	Custom Insertion Length		
SVC	For Vertical Receivers		
SVC36	36"	(914 mm)	Insertion Length
SVC48	48"	(1219 mm)	Insertion Length
SVC54	54"	(1372 mm)	Insertion Length
SVC60	60"	(1524 mm)	Insertion Length
SVCxx	Custom Insertion Length		

TO ORDER: Specify Catalog Number, Insertion Length, refrigerant, voltage, whether for a vertical or horizontal receiver and receiver diameter. (Insertion length is measured from the bottom of probe to the first thread on probe body.)

MATERIAL SPECIFICATIONS

CONTROL UNIT

Enclosure: 6.25" W X 4.25" H X 4.75" D; Splashproof
Power: 115V, 50/60Hz Standard
230V, 50/60Hz Optional
Digital Readout: Two digit L.E.D. display,
0.5" (13 mm) characters showing %.
Outputs: Two SPDT 10 ampere relays;
also, 0 to 5 volt (or 1 to 6 volt) D.C. (non-isolated)
proportional to liquid level
Linearity: Typically $\pm 2\%$ of actual
Terminal Strip: Accepts 14-22 AWG wire sizes
Ambient Temperature: 50F to 125F (10°C to 50°C)

PROBE

Fitting: $\frac{1}{4}$ " NPT male, plated steel
Probe Rod: Teflon enclosed stainless steel
Sensing Principles: Capacitance
Shielding Tube: Stainless steel (horizontal vessel
probes only)
Standard Active Probe Lengths:
Horizontal: 6", 8", 12", 15.3", 19.2", 23.1"
Vertical: 36", 48", 54", 60" (receivers up to 20" dia.)
(Special lengths to order)
Refrigerant Temperature: 50F to 150F (10°C to 65°C)
Safe Working Pressure: 400 PSIG (27 bar) SWP
Probe Cable Length: 36" fixed length, coaxial

APPLICATION

Horizontal Receivers: 6" to 24" diameter
Vertical Receivers: 12" to 20" diameter
(other diameters need special engineering)

ADVANTAGES

These level transducer probes come factory pre-calibrated and tested. There are no moving parts on the probe to break, jam or fail. Simple $\frac{1}{4}$ " NPT probe-to-receiver fitting. These probes and control units have been specifically designed to monitor the liquid level in refrigerant receivers. They provide a digital display of liquid level percentage. The digital display permits quick reading of liquid level. The "Anti-Splash" dampening feature ignores normal turbulence in the receiver to facilitate more accurate liquid level readings and prevent most "false alarms" and shut-downs.

The two SPDT 10 ampere relays enable alarms, cut-outs, and solenoid valves, etc. to react when changes in liquid levels occur. Also, a non-isolated 0 to 5 volt D.C. output signal is provided which is proportional to liquid level. However, the main usage and intent of the Level Cat® is to provide adjustable level switching rather than a refined level proportional electronic output.

DIGITAL READOUT

The control unit has a bright, L.E.D. digital readout which displays percentage of liquid immersed probe length from 00% through 99%. Above 99%, the readout is blank and the over-level light is lit; below 00%, the readout simply remains at 00%.

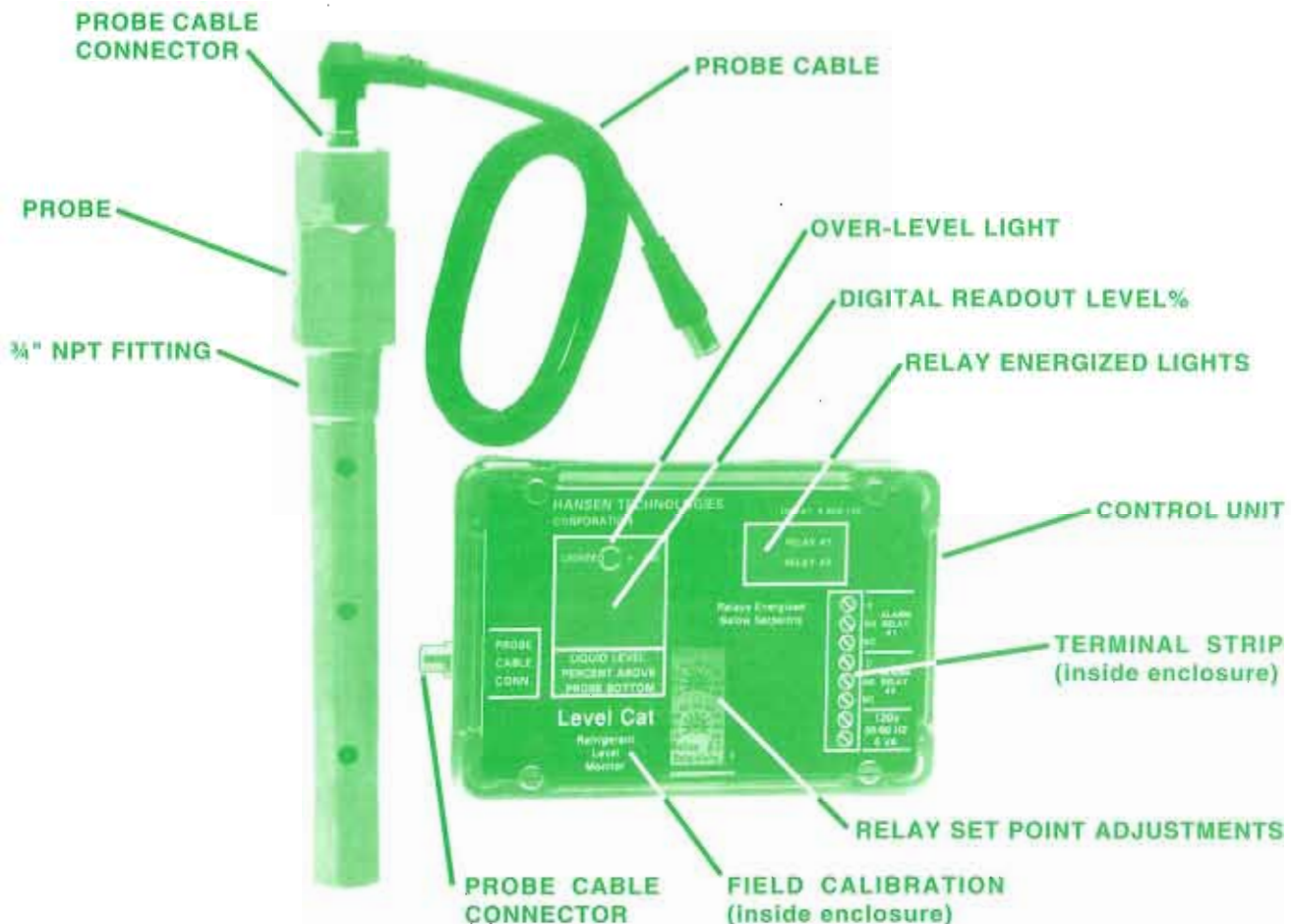

INSTALLATION

To select proper probe size, receiver inside height and fitting length should be known, see diagram below. Subtract 1.06" or 27 mm (typical engagement plus probe minimum clearance to receiver bottom) from "F" dimension; the result is the maximum possible insertion length of probe. Actual probe insertion length may be less, perhaps down to the next standard insertion length, provided it is long enough to measure lowest desired receiver level. Minimum clearance is suggested to avoid possible damage to probe by running it into bottom of receiver.

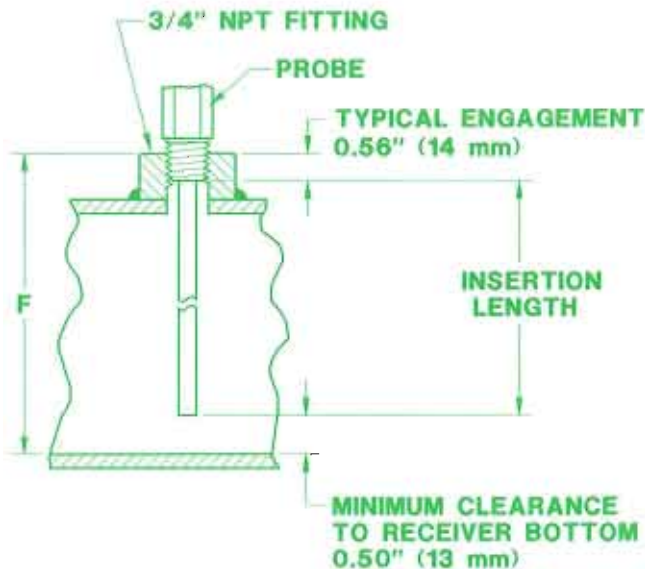

Locate fitting away from liquid inlet of receiver to avoid splashing probe with incoming refrigerant. Also, avoid possible probe mechanical interference with dip tube or other internal parts. Adequate clearance above the 3/4" FPT fitting on the receiver should be provided to permit the installation and removal of probe without bending.

These standard probes are not normally intended for insertion into evaporators or vessels containing boiling (or flashing) liquid. Other models are available for such applications.

Mount control unit in a solid location within 36" (914 mm) from probe. Allow space on sides of the control unit enclosure to permit the connection of the probe cable and other electrical connections.

Use the factory supplied 36" (914 mm) probe cable. Do not modify or use any other cable than the one provided. Normally, connect the angle end of the probe cable to the probe cable connector and the straight end to the external probe cable connector on the control unit. Do not allow moisture to collect under probe cable connector due to condensation or splashing water, especially on receivers operating below 50F (10°C). If necessary, use non-conductive grease inside of the fitting for moisture barrier.

PROBE INSTALLATION DIMENSIONS

For Horizontal Receivers

For Vertical Receivers

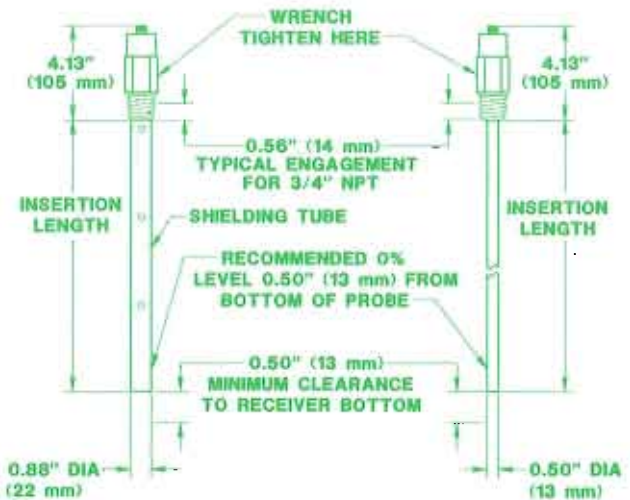

For Horizontal Receivers		
6"	(152 mm)	Insertion Length
8"	(203 mm)	Insertion Length
12"	(305 mm)	Insertion Length
15.3"	(387 mm)	Insertion Length
19.2"	(487 mm)	Insertion Length
23.1"	(586 mm)	Insertion Length
For Vertical Receivers*		
36"	(914 mm)	Insertion Length
48"	(1219 mm)	Insertion Length
54"	(1372 mm)	Insertion Length
60"	(1524 mm)	Insertion Length

*Horizontal Receiver Probes (SHP) should also be used in short, (less than 24" insertion), narrow or wide (less than 12" dia. or greater than 20" dia.) vertical receivers.

ELECTRICAL

The two SPDT (Single Pole Double Throw), 10 ampere resistive load relays, are suitable for voltages up to 250 VAC. Connect relay wiring at the internal terminal strip of the control unit. Fuse circuit(s) for 5 amp or less to protect Level Cat® from accidental short circuits or failure of alarm devices or controls. Note the logic of the relays: relays are energized when level is below set points.

The control unit requires an input power supply of 115V, 50/60Hz standard (230V, 50/60Hz optional). Note the voltage on the control unit nameplate and check the power supply at the wire leads to be sure that they are the same before connecting.

A non-isolated 0 to 5 volt D.C. output is standard with control unit; however, its use is optional. The two spade terminal located inside the control unit will supply a D.C. voltage signal proportional to liquid level. As with all non-isolated outputs, this output requires special precautions to prevent electrical noise and ground loops from entering circuit. Use best common practice when using this circuit.

RE-CALIBRATION INSTRUCTIONS

These transducer probes are accurately factory pre-calibrated for receivers with the specified refrigerant. Probes should not normally require any field adjustment in calibration settings. Note: various system and electrical conditions can cause erratic or inaccurate output. These conditions should be investigated before attempting to adjust calibration. To re-calibrate when necessary remove printed enclosure cover; with liquid level below the probe, adjust Z (zero) tiny brass calibration screw in left hand, blue rectangular potentiometer until digital readout shows 01%. Then establish a known level of liquid between 50% and 90%. Adjust S (span) tiny brass calibration screw in right hand blue potentiometer until digital readout shows the known level between 50% and 90%. If one determines that transducer probe cannot be satisfactorily calibrated or that refrigerant is other than that specified on control unit, contact factory for detailed calibration instructions.

RELAY SET POINTS

Each relay set point adjustment is a rotary dial located inside the control unit enclosure. The two rotary dials are labeled Relay #1 and Relay #2. The percentage values on the face of the dials relate to the liquid level in the receiver between the 10% level point and the 90% level point of the total probe insertion length.

Each set point has a 4% ($\pm 1\%$) differential above the set point. The relays will energize at the set point on a falling level and will not de-energize until the level rises 4% (differential) above set point. This differential generally avoids short cycling and false alarms due to brief surges in liquid level. Two bright red lights visible through the enclosure cover, labeled "RELAY #1" and "RELAY #2", indicate when the respective relays are energized.

CAUTION

These transducer probes and control units have been designed for refrigeration systems. These instructions and related safety precautions must be completely read and understood before selecting, using or servicing these controls. Only knowledgeable, trained refrigeration mechanics should install, operate or service these controls. Stated temperature and pressure limits should not be exceeded. Probes should not be removed from receiver unless system has been evacuated to zero pressure.

WARNING: As with all electronic and mechanical components, there is a limited life expectancy. An expected life of seven to ten years is typical. This should be understood as only a suggested replacement time period. Actual condition and performance of electronics due to ambient conditions, quality of electrical current, voltage, etc. may necessitate a different replacement schedule. Regardless, probes and control units should be inspected at least annually to insure their safe and continuous service. Probes are not safety controls and must be backed up by relief valves or other safety devices as appropriate for the particular system. See also Safety Precautions in current List Price Bulletin and Safety Precaution Sheet supplied with product. Escaping refrigerant might cause personal injury, particularly to the eyes and lungs.

WARRANTY

Hansen electronics are guaranteed against defective materials or workmanship for 90 days F.O.B. factory. All other components are guaranteed for one year F.O.B. factory. No consequential damages or field labor is included.

TYPICAL WIRING DIAGRAM

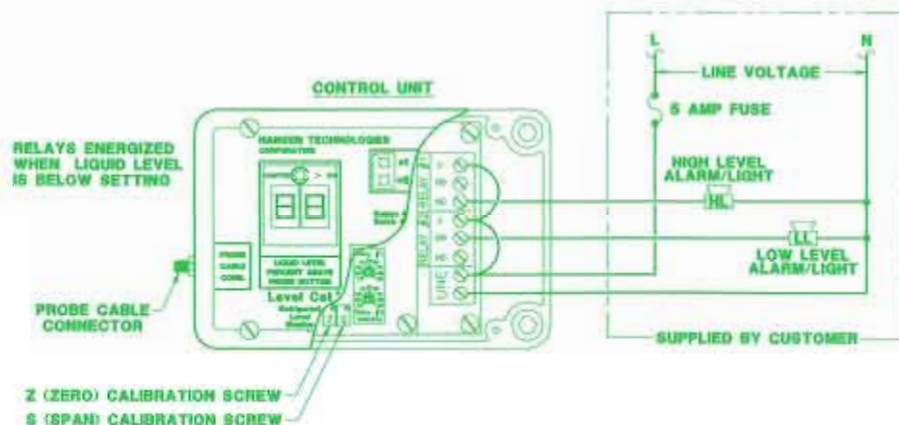

HANSEN TECHNOLOGIES CORPORATION

6827 High Grove Boulevard
Burr Ridge, Illinois 60521 U.S.A.
Telephone: (708) 325-1565
Toll-free: 1-800-426-7368
FAX: (708) 325-1572