

Specifications, Applications,
Service Instructions & Parts

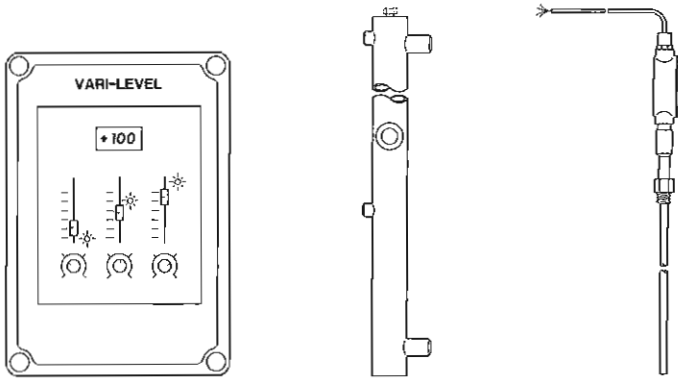

VARI-LEVEL ADJUSTABLE LEVEL CONTROL

for refrigerant pumping packages,
accumulators, receivers, intercoolers

CONTROL UNIT

LEVEL COLUMN

PROBE

INTRODUCTION

The advanced design of the Hansen VARI-LEVEL Control provides greater flexibility for refrigerant level control. This solid-state system can be quickly and easily changed for new control level set points. Each individual set point is adjustable for height and operating differential. In addition, a built-in simulator allows the operator to check proper operation of control valves, pumps, and alarms at various level set points. The performance of this control is not affected by reasonable variations in refrigerant temperature or pressure.

APPLICATIONS

The standard three point VARI-LEVEL is ideal for the control of the operating level in liquid refrigerant accumulators and separators, the high level alarm/compressor cut-out. While primarily designed for ammonia, R12, R22, R502 refrigerants, this control is also suitable for other liquids.

KEY FEATURES

- Digital display of level
- Factory calibrated
- "Anti-Splash" dampening feature
- 1 to 3 SPDT fused relay outputs
- Built-in level simulator
- Variable cable length to probe
- Various probe lengths
- Matching level columns available

ADVANTAGES

The digital display permits quick reading of liquid level and more accurate of adjustments. A built-in level simulator allows the actuation of relays for verification of control level set points. Each control level set point has an independent differential control. The low level and operating level differential logic is unique in that the differential is measured from the set point up; making it easier and more precise to set. The "Anti-Splash" dampening feature ignores normal turbulence in the level column to permit a more accurate liquid level reading and prevent most "false alarms" and shut-downs.

MATERIAL SPECIFICATIONS

CONTROL UNIT

Enclosure: 7-3/8"W x 16"H x 5-5/8"D NEMA 4
Power: 110-120V/60Hz Standard
220-240/50/60Hz Optional
Display: 3 digit L.E.D. display, 1/2" characters
Outputs: SPDT, 3 amp fused relays
0-1 ma, remote output
Operating temperature: -20°F to 120°F (enclosure)

PROBE

Enclosure: NEMA 4X aluminum box
Power: Low Voltage DC
Fitting: 3/4" MPT Connection to Level Column
Standard active probe lengths:
20", 30", 40", 60", 80", 100"
(Special lengths to order)
Max. working pressure: 360 PSIG
Operating temperature: -60°F to 150°F
Cable length: 50 ft. std.

LEVEL COLUMN

Enclosure: 3" Schedule 40 pipe
Sight glass: Located at 50% level (other levels to order)
Max. working pressure: 360 PSIG
Operating temperature: -60°F -150°F

LEVEL COLUMN INSTALLATION

When installing the level column, the insertion and removal of probes must be considered. Either adequate space above the level column or flanged connections and hand valves between the level column and vessel should be provided. Equalizer lines and valves should be positioned as shown in the Piping Installation diagram on page 9. Oil drain and optional independent high level "cut-out" float switch should be installed at this time. Pressure test level column for leaks.

PROBE INSTALLATION

Remove probe from packing crate, being careful not to let the probe bend. Use proper sealant on 3/4" MPT fitting on probe and insert in level column. Tighten probe on hex, do not grip housing. Pressure test for leaks.

ELECTRICAL

Note the voltage on the control unit nameplate and check the power supply at the wire leads to be sure that they are the same.

CONTROL UNIT INSTALLATION

Probes are supplied from factory with a 50 foot control cable. If control unit is to be located less than 50 feet from the probe, the control cable may be cut to length. If more than 50 feet, contact factory for instructions and longer cable. Mount control unit, which has a watertight transparent electrical enclosure, on a solid location away from the movement of material and equipment. Allow space below the control unit enclosure to permit the connection of the control cable and other electrical connections. See Control Unit enclosure dimensions below.

Protect control cable from damage. For maximum physical and electrical protection run cable inside of a conduit. If conduit is not used, feed the control cable through the watertight cable connector on the bottom of the control unit enclosure and the top of the probe housing. Trim the control cable and its four wires to a workable length. See pages 7 and 10 for control unit and probe wiring diagrams for proper color coded connections. Securely place control cable quick disconnect plugs into their appropriately marked sockets.

Connect power supply leads to line quick disconnect plug and securely place this plug into the appropriately marked socket.

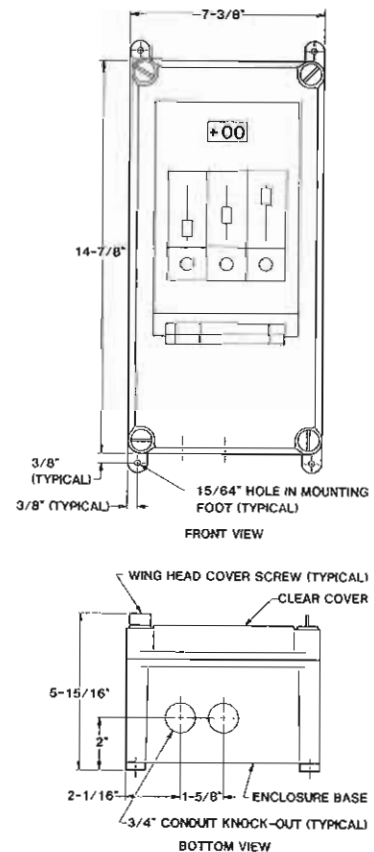

DIGITAL DISPLAY

HANSEN TECHNOLOGIES CORPORATION Pat. Pend

Vari-Level

÷ 00
LIQUID LEVEL
PERCENT ABOVE
PROBE BOTTOM

SIMULATION MODE
LEVEL SIMULATION
RELAY TESTING
SIMULATION SWITCH

LEVEL SIMULATION ADJUSTMENT SCREW

SIMULATION BUTTON (Push-In for simulation)

HIGH LEVEL CALIBRATION SCREW (Pre-calibrated)

HIGH LEVEL CALIBRATION

OPERATION MODE

LOW LEVEL CALIBRATION SCREW (Pre-calibrated)

LOW LEVEL CALIBRATION

SET POINT ADJUSTMENTS

LOW LEVEL	CONTROL LEVEL	HIGH LEVEL
100% — 80% — 60% — 40% — 20% — 0% —	100% — 80% — 60% — 40% — 20% — 0% —	100% — 80% — 60% — 40% — 20% — 0% —
LOW LEVEL	FILLING	HIGH LEVEL
10% 15% 2% 20%	10% 15% 2% 20%	10% 15% 2% 20%
LEVEL DIFFERENTIAL ADJUSTMENTS		

LEVEL SETTING SLIDE KNOBS

LEVEL DIFFERENTIAL KNOBS

0-1 MA OUTPUT	PROBE WIRING	LOW LEVEL RELAY	CONTROL LEVEL RELAY	HIGH LEVEL RELAY	115V LINE
	RED WHITE GREEN BLACK				

17 16 15 14 13 12 11 10 9 8 7 6 5 4 3 2 1

QUICK DISCONNECT PLUGS

RE-CALIBRATION

Control units are factory calibrated for the supplied probe and should not normally require field recalibration, unless probe length or refrigerant are changed. If recalibration is ever desired, only two points need to be checked, typically the 0% level and the sight glass % level point (normally at the 50% level point, but also possible at other levels).

To check the proper calibration at the 0% level point, the level column should be completely free of liquid. This can be accomplished by emptying the vessel or by closing the valve in the upper equalizer line while the hand valve in the lower equalizer line is open. It may take several minutes for the column evaporation to push the liquid surface down below the probe. With the level column free of liquid the control unit's digital display should be at +00%. If not, remove seal on the low level calibration screw and adjust with a small screwdriver until display indicates +00%; replace seal.

To check the sight glass % level point, some basic calculations need to be made. See Calibration diagram in the next column. Add 9 inches to probe's stated factory set Active Length(A) measure this distance from the reference line (yellow line around probe body) down. This will be the 0% level point on the outside of the level column. Measure up from this 0% level point to the center of the sight glass and divide by the desired active length (usually the factory stated active length). This is the level in percentage points at which the sight glass is located (Hansen Level Column standard sight glass location is 50%). Raise or lower the liquid inside the level column so that it is centered in the sight glass. The digital display should be the same as the calculated sight glass % level. If not, remove the seal on the high level calibration screw and adjust until digital display equals the calculated sight glass % level; replace seal.

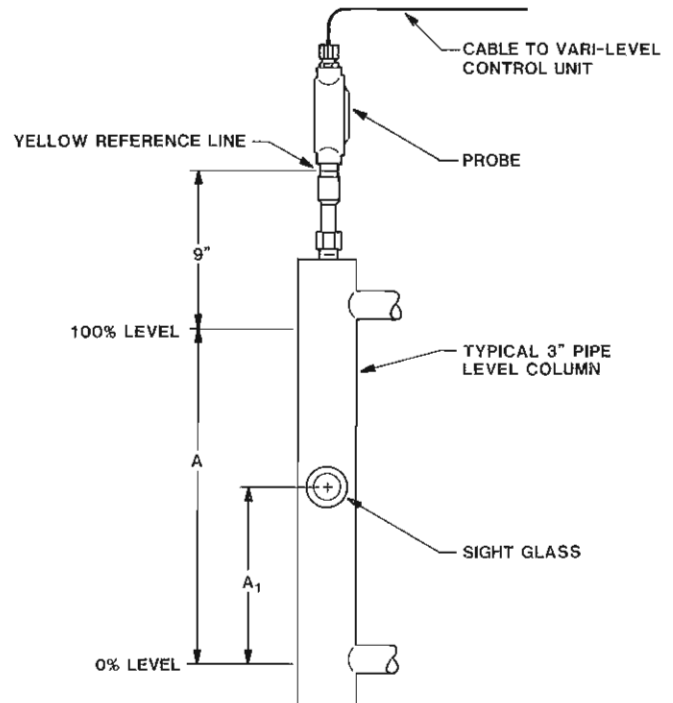

$$0\% \text{ Level} = 9" + \text{Active Length (A)} \text{ below reference line}$$

$$\text{Sight Glass \% Level} = \frac{A_1}{\text{Desired Active Length}}$$

WIRING OF RELAYS

Each relay is individually fused at 3 amps. Follow good electrical wiring practice when connecting any wiring. The control unit wiring diagram presented on page 10 is only one suggested approach to relay circuitry. Before connecting relay circuits, refrigeration system operation and design should be carefully reviewed. Wiring of relays should be designed so that in case of power failure relay circuits will be in a safety mode for the refrigeration system. After being connected, the relay circuits may be checked by using the built-in simulator as explained on page 12.

RELAY LEVEL SET POINTS AND DIFFERENTIALS

Each level set point adjustment control is a slide knob which is calibrated in percentage value of probe active length. The percentage values relate to the liquid level in the column between the 0% level point and the 100% level point.

Each level differential adjustment control is a rotating knob which is also calibrated in percentage value of probe active length. However, these percentage values relate to number of percentages points above or below the set point, depending on the relay, at which the relay position will change.

Low Level Adjustment-This relay set point is the lowest level that the liquid in the level column should be allowed to reach before the operation of an alarm or equipment cut-out. After setting the low level set point, set the differential adjustment control so that the relay will energize when the liquid in the level column **RISES** this percentage value **ABOVE** the low level set point. The Low Level indicator light (red) will be on when the relay is de-energized.

Control Level Adjustment-This relay set point is to maintain the level inside the vessel via a supply solenoid valve or other control. The control level set point is the level at which make-up liquid will start to feed to the vessel. The differential adjustment control should be set so that the relay will de-energize when the level **RISES** this percentage value **ABOVE** the control level relay set point. The Filling indicator light (green) will be on when the relay is energized.

High Level Adjustment-This relay set point is to protect the liquid level from becoming too high. The high level set point is the highest level that the liquid should ever reach before an alarm or equipment cutout occurs. The differential adjustment control should be set so that the relay will energize when the level **FALLS** this percentage value **BELOW** the high level relay set point. The High Level indicator light (red) will be on when the relay is de-energized.

(See also Control Unit Wiring Diagram.)

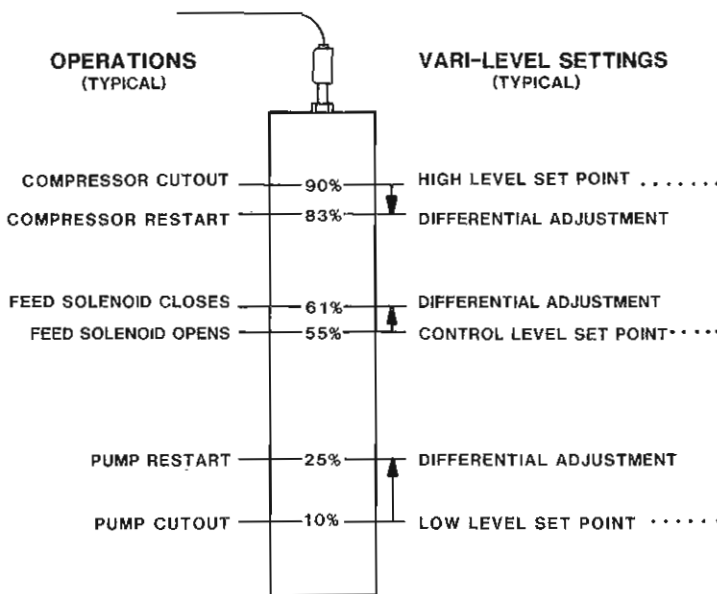

This diagram illustrates typical set point and differential settings. Actual settings will depend on the requirements of the individual system and its operation. Actual operation of controls and alarms will depend on wiring.

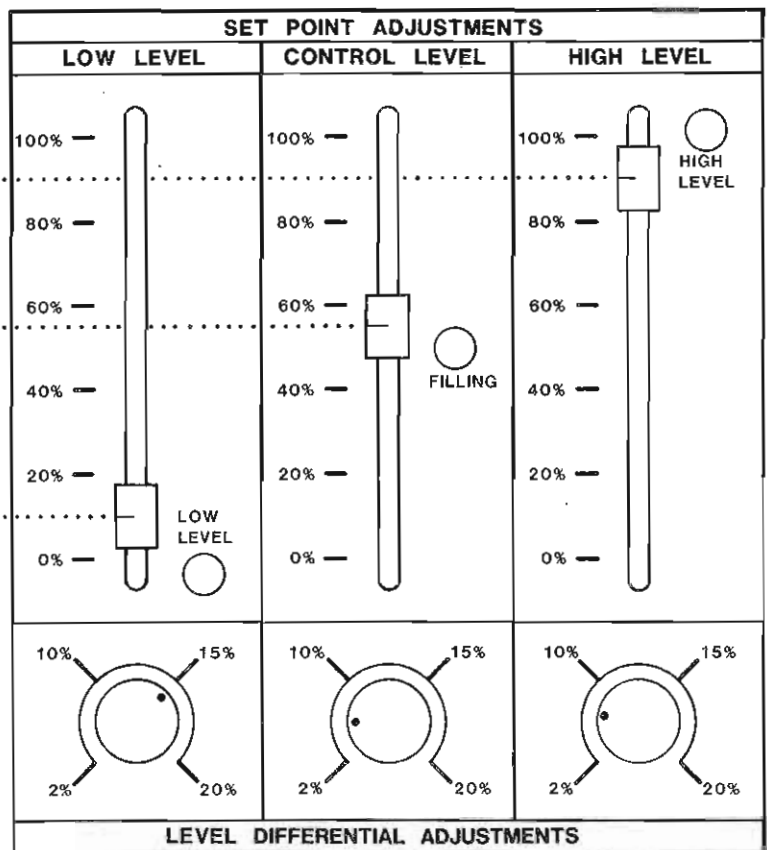

PROBE DIMENSIONS

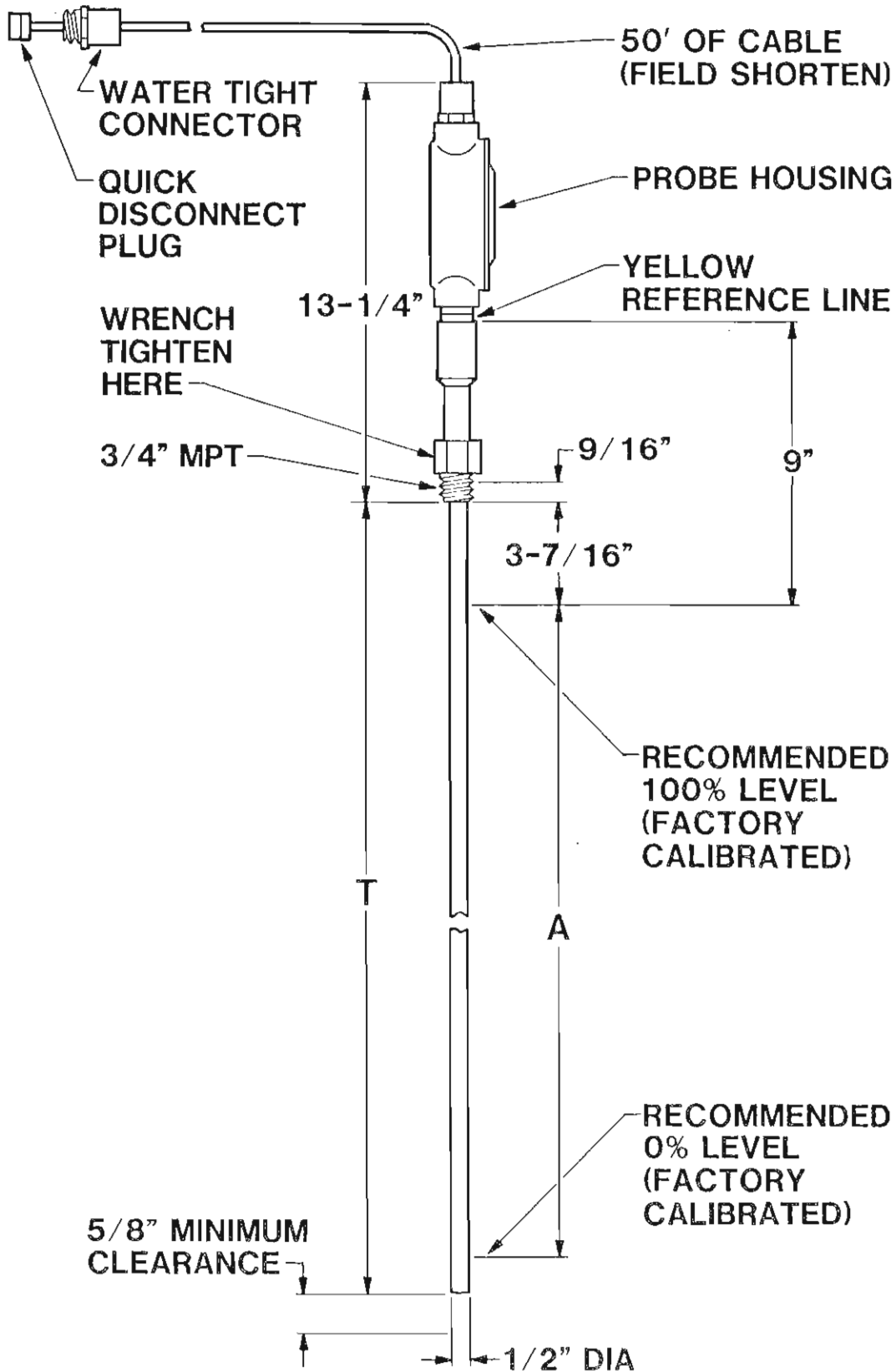

A (ACTIVE LENGTH)	20"	30"	40"	60"	80"	100"
T (INSERTION LENGTH)	24-1/4"	34-3/8"	44-1/2"	64-11/16"	84-13/16"	105"

PROBE WIRING

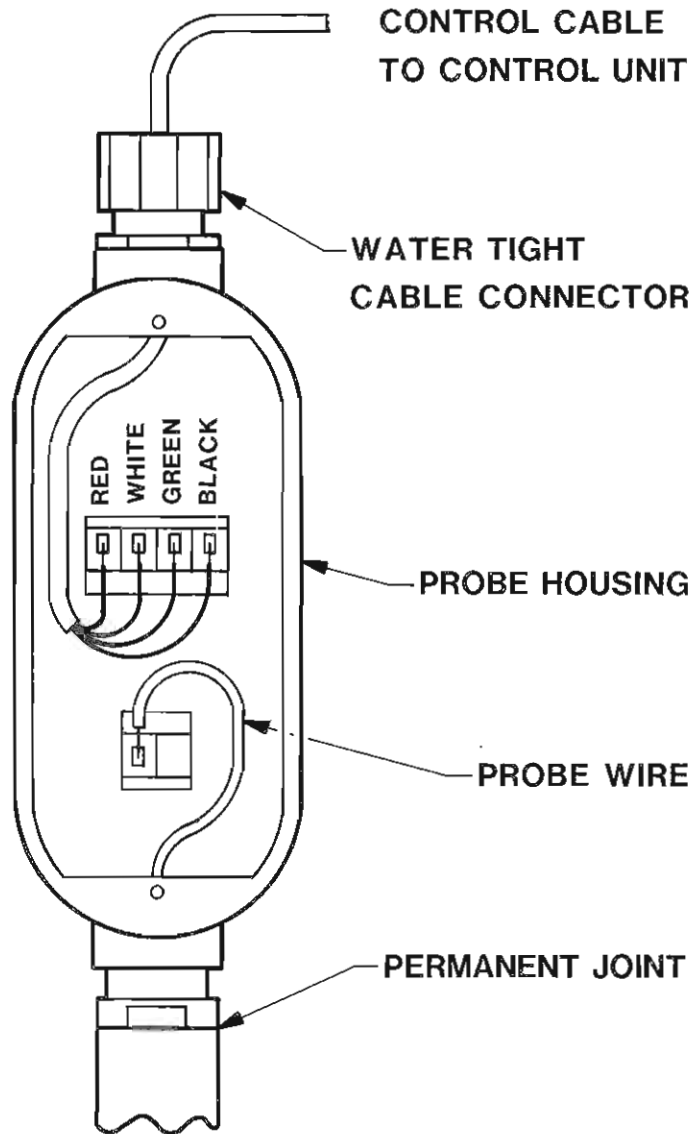

**UNIVERSAL LEVEL COLUMN
(PROBE STANDPIPE)**

CATALOG NUMBER	PROBE ACTIVE LENGTH A	EQUALIZER LEGS E	FLOAT SWITCH LEG F	SIGHT GLASS LOCATION G	PROBE REMOVAL HEIGHT H	COLUMN OVERALL LENGTH L
LC.01	10"	11-1/4"	13-1/2"	9"	30"	16-1/2"
LC.02	20"	21-1/4"	18-1/2"	14"	40"	26-1/2"
LC.03	30"	31-1/4"	31-1/8"	19"	50"	36-1/2"
LC.04	40"	41-1/4"	36-1/8"	24"	60"	46-1/2"
LC.06	60"	61-1/4"	46-1/8"	34"	80"	67-1/4"
LC.08	80"	81-1/4"	56-1/8"	44"	100"	87-1/4"
LC.10	100"	101-1/4"	66-1/8"	54"	120"	107-1/4"
LC.12	120"	121-1/4"	76-1/8"	64"	140"	127-1/4"

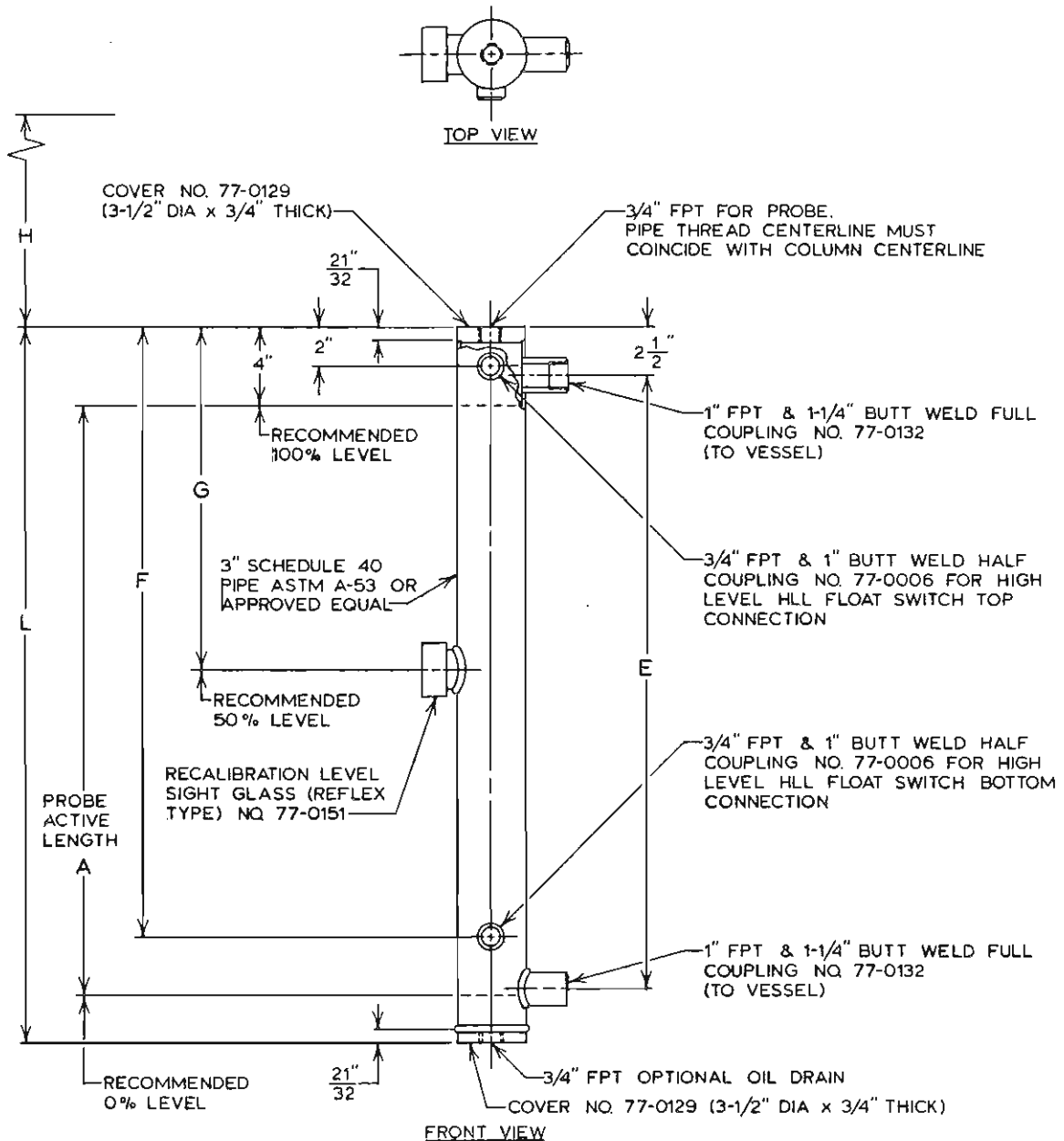

COMPLETE LEVEL COLUMN OR PARTS THEREOF AVAILABLE FROM HANSEN TECHNOLOGIES.
LEVEL COLUMNS ARE SUPPLIED WITH PLUGS FOR THE OIL DRAIN AND HIGH LEVEL FLOAT SWITCH CONNECTIONS.

Level Columns are supplied with plugs for the oil drain and high level float connections.

LEVEL COLUMN PIPING INSTALLATION

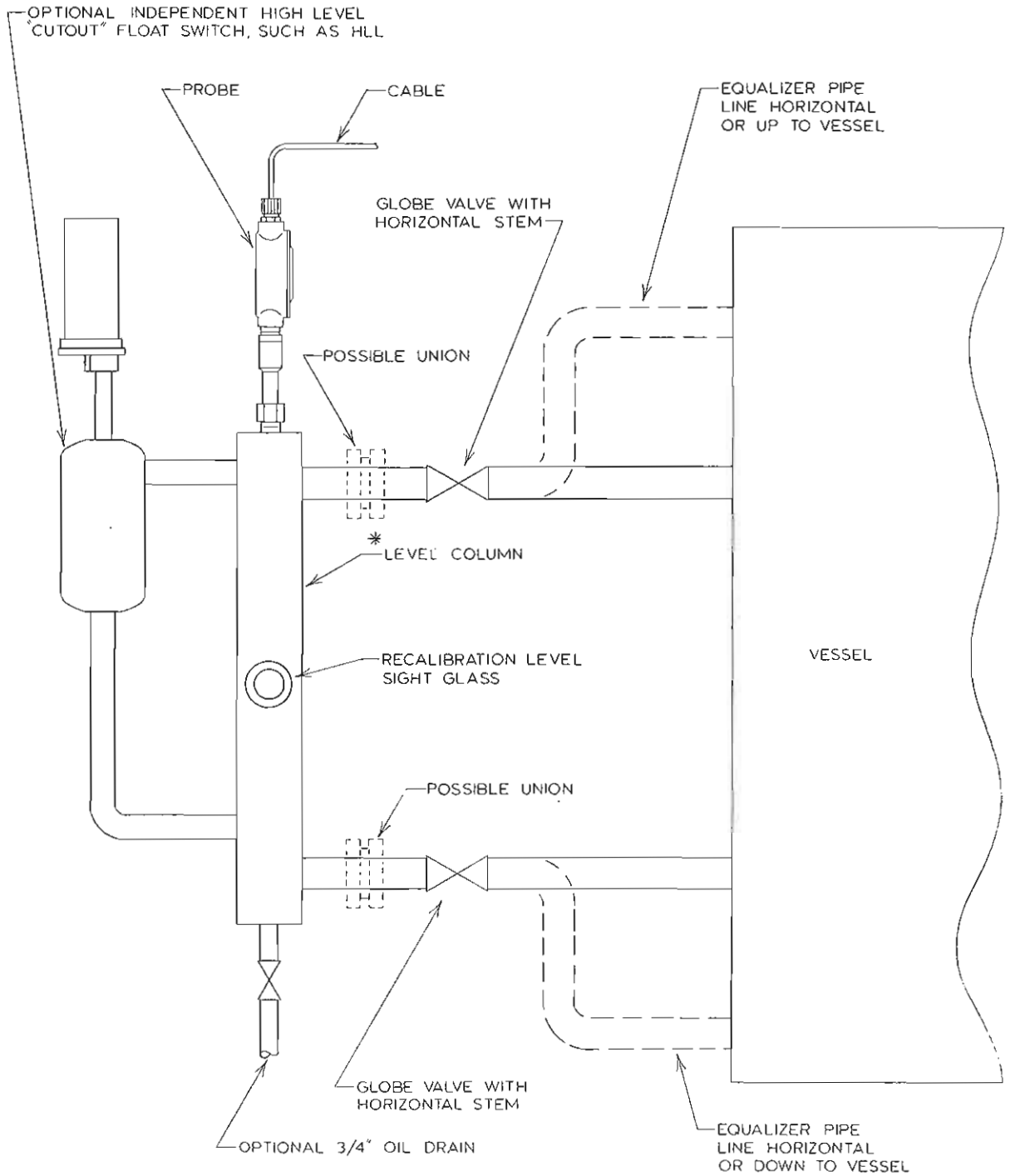

* ALLOW SPACE FOR INSULATION WHERE AND AS NECESSARY. USUALLY THE LEVEL COLUMN IS INSULATED TO REDUCE BUBBLING.

CONTROL UNIT WIRING

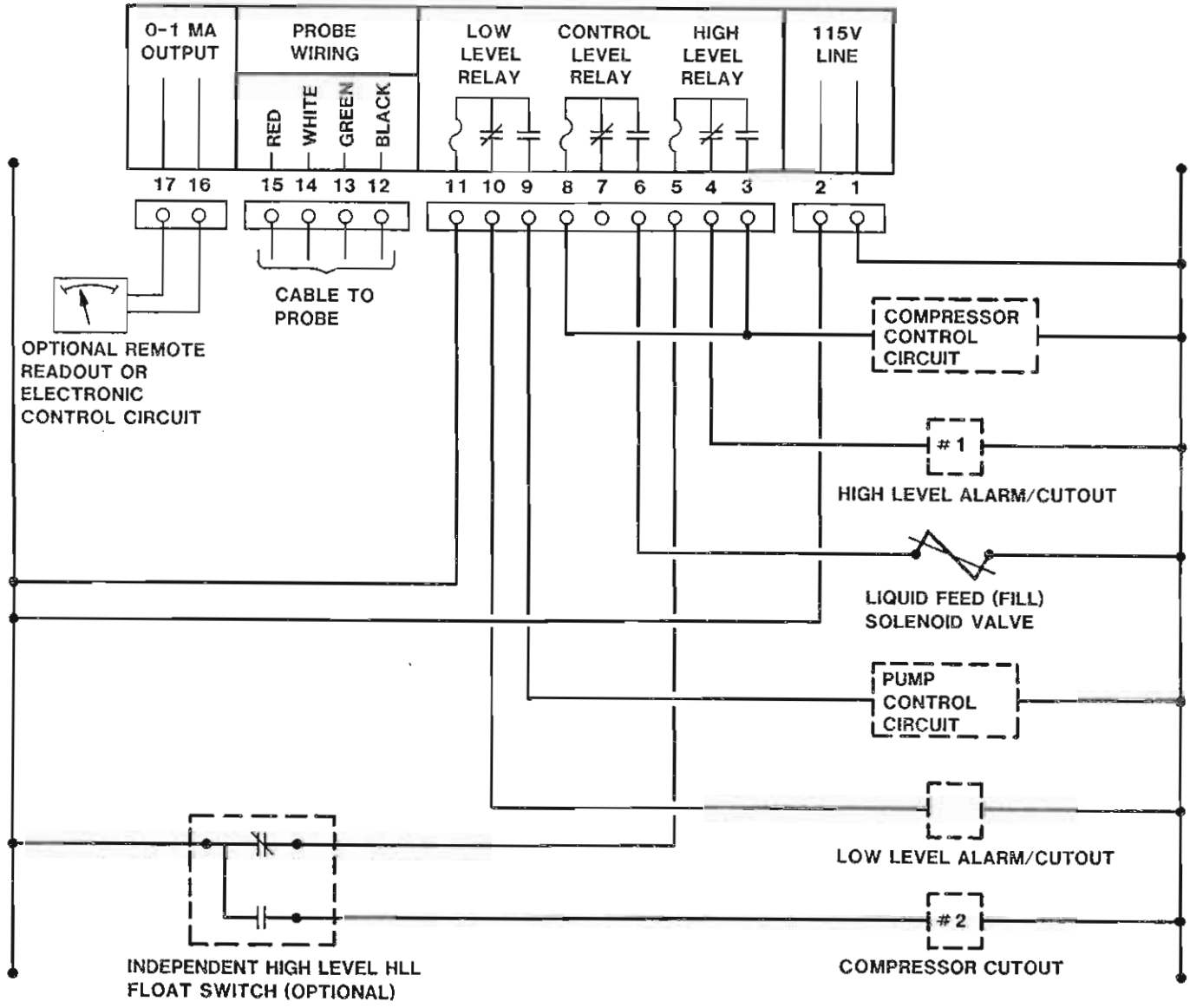

NOTE: Wiring diagram shown is one suggested method of control for illustration purposes only. Other wiring diagrams are possible to meet specific control requirements. Refer to manufacturer's wiring diagrams for proper wiring of controls. Final wiring details are the responsibility of the system designer.

TROUBLESHOOTING

If the VARI-LEVEL does not yield satisfactory results, follow this procedure:

1. Check to see that the VARI-LEVEL control unit is labeled for the correct refrigerant and correct probe length.
2. Check wiring between control unit and probe. Color dots on four connection plugs should match color of control cable wires. Check probe wire connection. Refer to wiring diagrams for proper wire connections.
3. With the probe wire removed from its socket, check the insulating resistance of the teflon probe using a 500V "Megger". Connect positive side to probe wire, negative side to probe housing. Result must be over 500 M Ω .
4. To verify proper operation of relays, change the percentage value with the simulation mode button and the level simulation adjustment screw. See Simulation section on page 12.
5. If Steps 1, 2, 3, and 4 are OK, check refrigeration conditions.

Troubleshooting Chart

Symptom	Probable Cause	Cure
No numbers displayed on the digital display; LED lights do not light up.	Low or no voltage at the power line connections.	Restore correct voltage.
Digital display indicates too low of a level compared to sight glass.	<ol style="list-style-type: none"> 1. Too much oil in the level column (only with NH₃). 2. Control unit not calibrated or insulating resistance of the teflon enclosed probe rod is too low, must be infinite. 	<ol style="list-style-type: none"> 1. Drain off the standpipe. 2. Calibrate at zero and recalibration level. Check the probe insulating resistance with a "Megger", if defective, replace the probe.
Digital display does not indicate level changes.	<ol style="list-style-type: none"> 1. Poor pipe connection between level column and vessel. 2. The stop valve(s) may be closed or improperly positioned. 3. The connections may be clogged with oil or debris. 	<ol style="list-style-type: none"> 1. Check the valve locations and orientation. 2. Open valves. 3. Remove oil and/or debris from the connections between vessel and level column and from bottom of level column.
No voltage output on either side of relay.	Fuse blown in Control Unit.	Check fuse and replace if blown.
Digital display indicates too high of a level compared to sight glass (only at low temperature.)	Level column is not insulated. Liquid boiling in level column.	Insulate the level column.

NOTES:

If there is a power failure or fault in the power pack on the control unit, the relays will go to the de-energized position.

SIMULATION

To check system operation of the level set points and differentials enter the simulation mode by depressing the simulation button and hold; amber Simulation Mode light will be on.

IMPORTANT: Control devices (solenoid valves, contactors, etc.) can operate while in the simulation mode. For electrical checkout be sure compressor motor, pump motor, etc., main circuits are disconnected where necessary to prevent damage.

The control unit is now in the simulation mode and the digital display shows the simulated (pretended) liquid level. With a small screwdriver rotate the level simulation adjustment screw to change the simulated liquid level. Observe the operation of the relays. If necessary, make adjustments in set points and differentials. When all relay level Set Points and Differentials are properly set, return the simulated level to a percentage value between the Control level and High level settings (prevents the unexpected operation of relays during the next simulation). Simply release the simulation button to return to normal operation; green Operation Mode light will be on. The percentage value displayed will now be that of the actual liquid level in the level column and the relay positions will respond to this level.

SAFE OPERATION

Hansen VARI-LEVEL controls have been designed for refrigeration systems. These instructions and related safety precautions must be completely read and understood before selecting, using, or servicing these controls. Only knowledgeable, trained refrigeration mechanics should install, operate, or service these controls. Stated temperature and pressure limits should not be exceeded. Probes should not be removed from level columns unless system has been evacuated to zero pressure. See also Safety Precautions in current List Price Bulletin.

WARRANTY

Hansen VARI-LEVEL electronics are guaranteed against defective materials or workmanship for 90 days F.O.B. factory. All other Vari-Level Components 1 year F.O.B. No consequential damages or field labor is included.

ORDERING INFORMATION, VARI-LEVEL CONTROLS AND LEVEL COLUMNS

CONTROL UNIT (Less Probe)		
Relays	Control Points	Cat. No.
3	Control, Low, and High Level	LB3
2	Control & Low Level	LB2
1	Control Level	LB1

Probe Active Length*	Probe Cat. No.	Level Column Cat. No.†
20"	LP.02	LCR.02
30"	LP.03	LCR.03
40"	LP.04	LCR.04
60"	LP.06	LCR.06
80"	LP.08	LCR.08
100"	LP.10	LCR.10

*These are standard Probe Active lengths; other lengths are available. † These are Right Hand columns (vessel on right). Order LCL for Left Hand.

TO ORDER: Specify control unit catalog number, refrigerant, probe catalog number and active length, and level column catalog number if required.

TYPICAL SPECIFICATIONS

"Refrigerant variable level controls shall have solid state electronics, digital displays, set point and differential adjustments, teflon enclosed probe rods and be suitable for refrigeration environments. Level controls shall be "VARI-LEVEL" as manufactured by Hansen Technologies or approved equal."

HANSEN TECHNOLOGIES CORPORATION

129 West 83rd Street
Burr Ridge, Illinois 60521
Telephone: (312) 325-1565
Outside Illinois: 1-800-426-7368
FAX: (312) 325-1572

Telex:
206851