

## HANSEN TECHNOLOGIES CORPORATION



Control Unit



Probe

### INTRODUCTION

The Hansen Vari-Level® provides excellent level control and monitoring flexibility for industrial and large commercial refrigeration systems. It takes the place of multiple single point level switches on new or existing refrigerant vessels. This popular and field-proven system consists of a control unit, probe and level column. Level set points and differentials can be easily set up, and then simply changed by moving knobs when necessary. A built-in level simulator enables the operator to easily check proper operation of control valves, pumps, and alarms at the various set levels.

### APPLICATIONS

While primarily designed for Ammonia, R22, R134a, and other approved refrigerants, this control is also suitable for other approved liquids. The standard three point Vari-Level® control unit, catalog number LB3, is ideal for the control of the operating level, high level alarm/compressor cutout, and the low level alarm/pump cutout in liquid refrigerant accumulators and separators. The single point and two point control units, catalog numbers LB1 and LB2 respectively, are suitable for operating level or low level control where an adjustable level with relay output and digital display is important. The five point control unit, catalog number LB5, is uniquely useful on larger systems where dual liquid feed solenoid and expansion valves give smoother control; by utilizing two control level relays from the LB5, it is possible to avoid a single, large liquid feed (especially 1½" and larger) which can exhibit "water hammer" when the solenoid valve opens or closes.

## Specifications, Applications, Service Instructions & Parts

### Vari-Level® ADJUSTABLE LEVEL CONTROLS

for Refrigerant Recirculator  
Packages, Accumulators,  
Receivers, and Intercoolers



ISO 9002

### KEY FEATURES

- Adjustable levels and differentials
- Bright digital display of level percentage
- User friendly
- Level Set Points always visible
- Accurately factory calibrated
- "Anti-Splash" dampening feature
- 1 to 5 SPDT fused relay outputs
- Built-in level simulator
- Variable cable length to probe
- Various probe lengths, including custom
- Matching level columns available
- Optional 4-20 mA output
- Suitable for Ammonia, R22, R134a and other approved refrigerants
- Many hundreds successfully in use
- CSA/US Certified

### ADVANTAGES

The bright and easily-seen LED digital readout clearly displays liquid level percentage. Each control level set point also has an independent differential control. The low level and operating level differential is easy to understand because it occurs from the set point upward. The "Anti-Splash" dampening feature ignores nominal turbulence in the level column to permit a more accurate liquid level reading and avoid most "false alarms" and shut-downs. A built-in level simulator enables the operator to realistically actuate relays for verification of control level set points and differentials. The overall performance of this control is not affected by normal variations in refrigerant temperature, pressure or contamination.

## MATERIAL SPECIFICATIONS

### CONTROL UNIT

Enclosure: Polycarbonate, watertight NEMA 4 (IP65)  
Power: Standard 115V, 50/60Hz  
Optional 230V, 50/60Hz  
Digital Readout: 3½ digit LED, 0.5" characters  
EMC Emission: EN50081-1  
EMC Immunity: EN50082-1  
Outputs: SPDT relay, (3 amp fused);  
Optional 4–20 mA output (MOD420);  
Maximum Load Resistance: 1200 ohms  
Ambient Temperature: +32°F to +120°F (0°C to +49°C)  
(control unit)

### PROBE

Probe Housing: NEMA 4 (IP65)  
Power: Low voltage DC  
Fitting: ¾" MPT Connection to Level Column  
Probe Rod: Teflon®-enclosed stainless steel  
Sensing Principle: Capacitance  
Standard Active Probe Lengths: 20", 30", 40", 60", 80",  
100", 120", 144", and 168" (Special lengths to order)  
(maximum 168" active length)  
Safe Working Pressure: 400 PSIG (27 bar) SWP  
Standard Operating Temperature: -60°F to +150°F  
(-50°C to +65°C); below -60°F (-50°C) requires  
the stainless steel extended neck body,  
contact the factory.  
Control Cable: 4 conductor wire with foil shield  
and grounding (drain) wire, 22 AWG, length 50  
feet (15 meters); longer lengths available.

### LEVEL COLUMN

Body: 3" Schedule 40 steel pipe, standard  
Sight Glass: Located at 50% level  
Safe Working Pressure: 400 PSIG (27 bar) SWP  
Operating Temperature: -60°F to +240°F (-50°C to +115°C)

## CONTROL UNIT

The control unit houses the "brains" of the Vari-Level®, its digital readout, knobs for adjusting set points and differentials, and the relays themselves. Because the signal from the probe is unique, it requires the control unit to interpret and convert it to an understandable signal and display. This new signal can be converted to a common 4–20 mA remote signal by the optional MOD420 Output Module which mounts inside of the control unit.

Mount the control unit, which has a watertight enclosure, in an accessible area away from the movement of material and equipment. Mounting requires four 0.25" diameter by 0.5" or longer screws, see control unit installation dimensions below. Allow space below the control unit to permit the connection of the control cable and other electrical connections. Any additional knock-outs for conduit connections must be located at bottom of control unit enclosure. **CAUTION: Do not install conduit connections into top of control unit; water can condense in conduit and drip down on control unit electronics, causing failure.**

See page 8 for control unit electrical wiring diagram. Before connecting electrical power, check the voltage on the control unit nameplate and the power supply at the wire leads to be sure that they are the same. Supply voltage must be within +10% or -15% of listed voltage. Connect power supply leads to the quick disconnect plug (Terminals 1 & 2) and secure into the appropriate marked socket.

## CONTROL UNIT INSTALLATION DIMENSIONS (SAME FOR LB3, LB2, LB1, LB5)

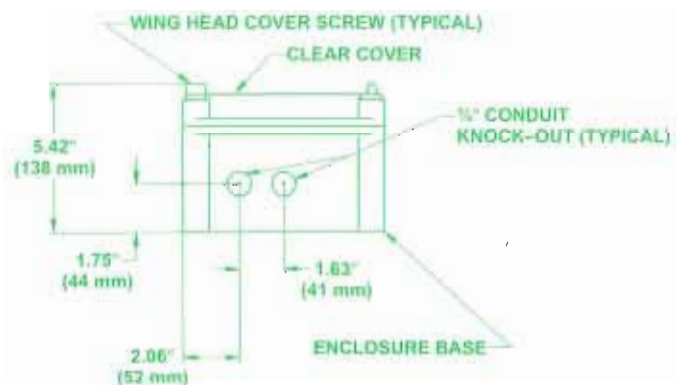
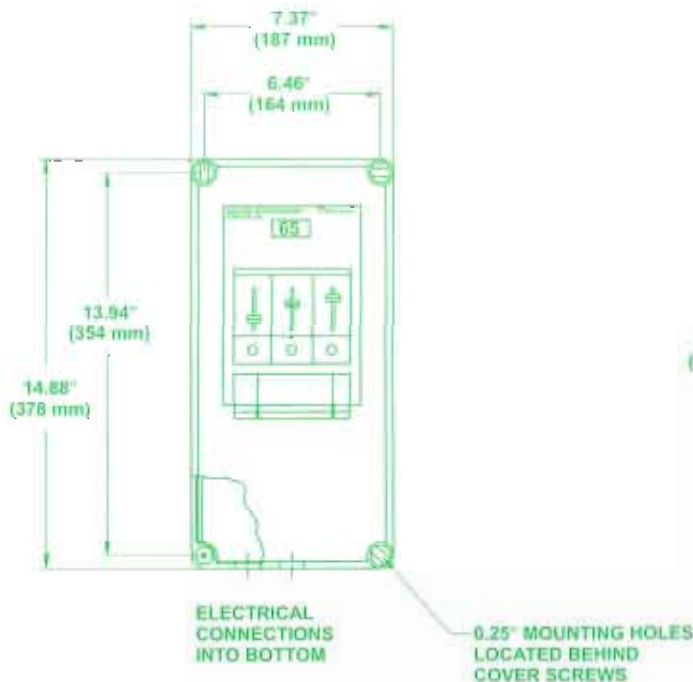

## LEVEL COLUMN PIPING INSTALLATION (Schematic Only, Not for Construction)

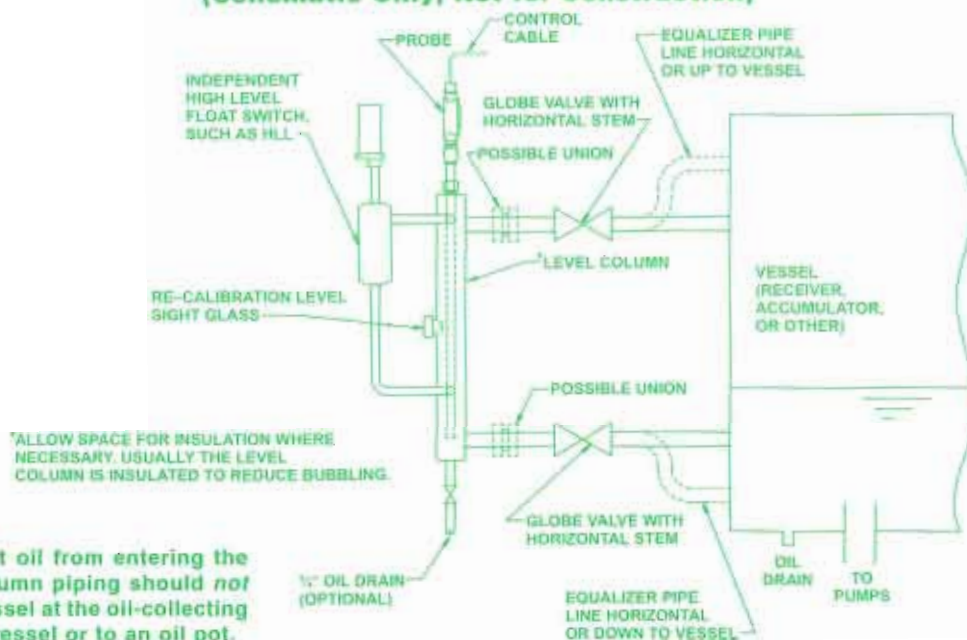

NOTE: To prevent oil from entering the column, level column piping should *not* connect to the vessel at the oil-collecting low point of the vessel or to an oil pot.

### LEVEL COLUMN

The 3" pipe level column offers a stabilized area where liquid level can be accurately measured. It also facilitates recalibration and probe isolation when necessary. Level columns can be supplied from Hansen or fabricated in the field. See page 6 for level column details and dimensions. 4" size pipe column can be used as an alternate.

Adequate space above the level column, or flanged union connections and shut-off valves between the level column and vessel, should be provided for probe insertion and removal. Follow good piping practice and refrigeration system maintenance to avoid oil accumulation inside the level column. Equalizer lines and valves should be positioned as shown above in the Level Column Piping Installation diagram. Equalizer shut-off valves and pipe lines must not trap oil or liquid. Shut-off valves enable the column to be isolated or blown-down for oil removal. Level column should be insulated where refrigerant temperature is significantly below ambient to avoid bubbles.

Oil drain valve and recommended independent high level "cutout" float switch are normally installed. The mechanical float switch adds an extra degree of protection to costly equipment in the event of unauthorized tampering to level settings, and abnormal system or electrical malfunction. Pressure test the level column, associated piping and fittings for leaks. Insulate level column, float switch and equalizer lines including valves.

On halocarbons systems, over a period of time, the refrigerant in the level column may become oil rich. An extremely high concentration of oil may cause the original calibration to become offset, thus causing a false reading of refrigerant level. To prevent this, periodically remove oil from the level column, via the oil drain valve or close the upper (only) globe valve for a while.

### PROBE

The probe is the device which actually measures the liquid level. It accomplishes this by sending a small, specialized signal out into the refrigerant liquid and vapor. This signal returns via the level column back to electronics inside probe housing. The strength of the returning signal is measured to determine level. This information is continuously sent to the control unit through the control cable. See page 7 for probe dimensions. Probe length cannot normally be altered in the field.

When installing the probe, match its serial number with the control unit. Remove the probe from the packing crate, being careful not to bend or whip the probe. Use nonelectrically isolating pipe thread sealant (**do not use Teflon<sup>®</sup> tape**) on the 3/4" MPT fitting on the probe and insert in top of the level column. Tighten probe on hex; do not grip probe housing flats or electrical box. Pressure test for leaks.

Probes are supplied from the factory with 50 feet of shielded control cable. If the control unit is located less than 50 feet from probe, trim the control unit end of the cable as necessary. Wrap foil shield and grounding wire inside electrical tape or shrink tubing to prevent contact with other wires. Longer lengths may be ordered or else use shielded 22 AWG wire. For maximum physical and electrical protection, run the control cable inside a separate metal conduit. If conduit is used, seal the inside of the connection to prevent water or other contaminates from running into the probe housing. See the probe wiring diagram on page 9 for proper color-coded wiring of the quick disconnect plug inside the probe housing. Bring the control cable through the conduit or the supplied watertight cable connector to the bottom of the control unit. Securely place the control cable quick disconnect plug into the appropriate marked socket inside the control unit.

## RELAY LEVEL SET POINTS AND DIFFERENTIALS

Each level set point adjustment control is a slide knob with a scale in percentage of active probe length. The percentage relates to the liquid level in the column between the 3% level point and the 100% level point, as measured from the probe bottom end.

Each level set point has a level differential adjustment control which is a rotating knob scaled in percentage of active probe length from 2% to 20%. These percentages relate to the number of percentage points above or below the set point at which the particular relay position will change, as detailed in the next three paragraphs.

**LOW LEVEL ADJUSTMENT**—This set point is intended to be the lowest level that the liquid in the level column should be allowed to reach before the operation of an alarm or equipment cutout, such as a recirculating pump. Set the differential adjustment control so that the relay will energize when the liquid in the level column RISES this percentage value ABOVE the low level set point. The low level indicator light (red) will be on when the relay is de-energized, that is when the level falls below the low level set point. The LB5 has two independent low level relays.

**CONTROL LEVEL ADJUSTMENT**—This set point is intended to maintain the level inside the vessel via a liquid refrigerant supply solenoid valve with a hand expansion valve or other control. The control level set point is the level at which make-up liquid will start to feed the vessel. This differential adjustment control should be set so that the relay will de-energize when the level RISES this percentage value ABOVE the control level relay set point and thereby closing the feed solenoid valve. The filling indicator light (green) will be on when the relay is energized. The LB5 has two independent control level relays in order to use two staged solenoid valves.

**HIGH LEVEL ADJUSTMENT**—This set point is intended to signal that the liquid level is becoming too high. The high level set point is the highest level that the liquid should ever reach before an alarm or equipment cutout occurs. The differential adjustment control should be set so that the relay will energize when the level FALLS this percentage value BELOW the high level relay set point and discontinue the high level signal. The high level indicator light (red) will be on when the relay is de-energized.

## TYPICAL CONTROL UNIT SETTINGS

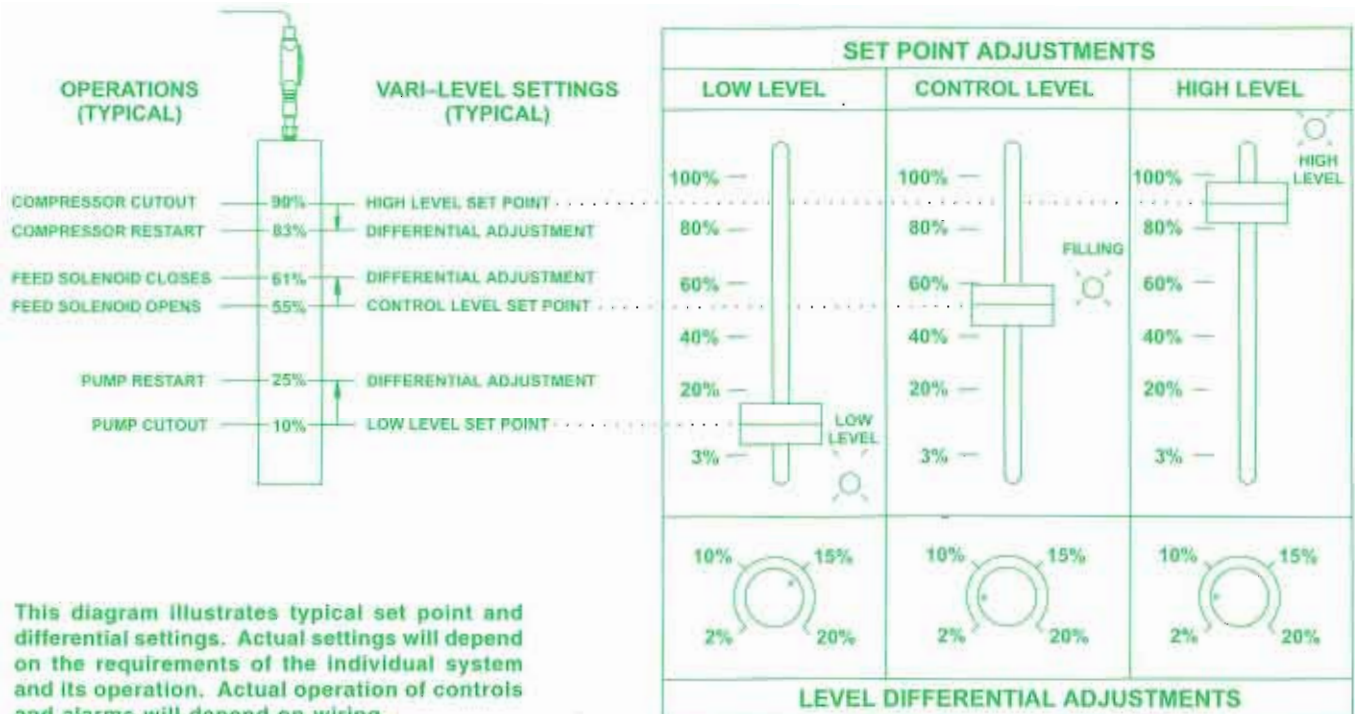



## LEVEL COLUMN DIMENSIONS

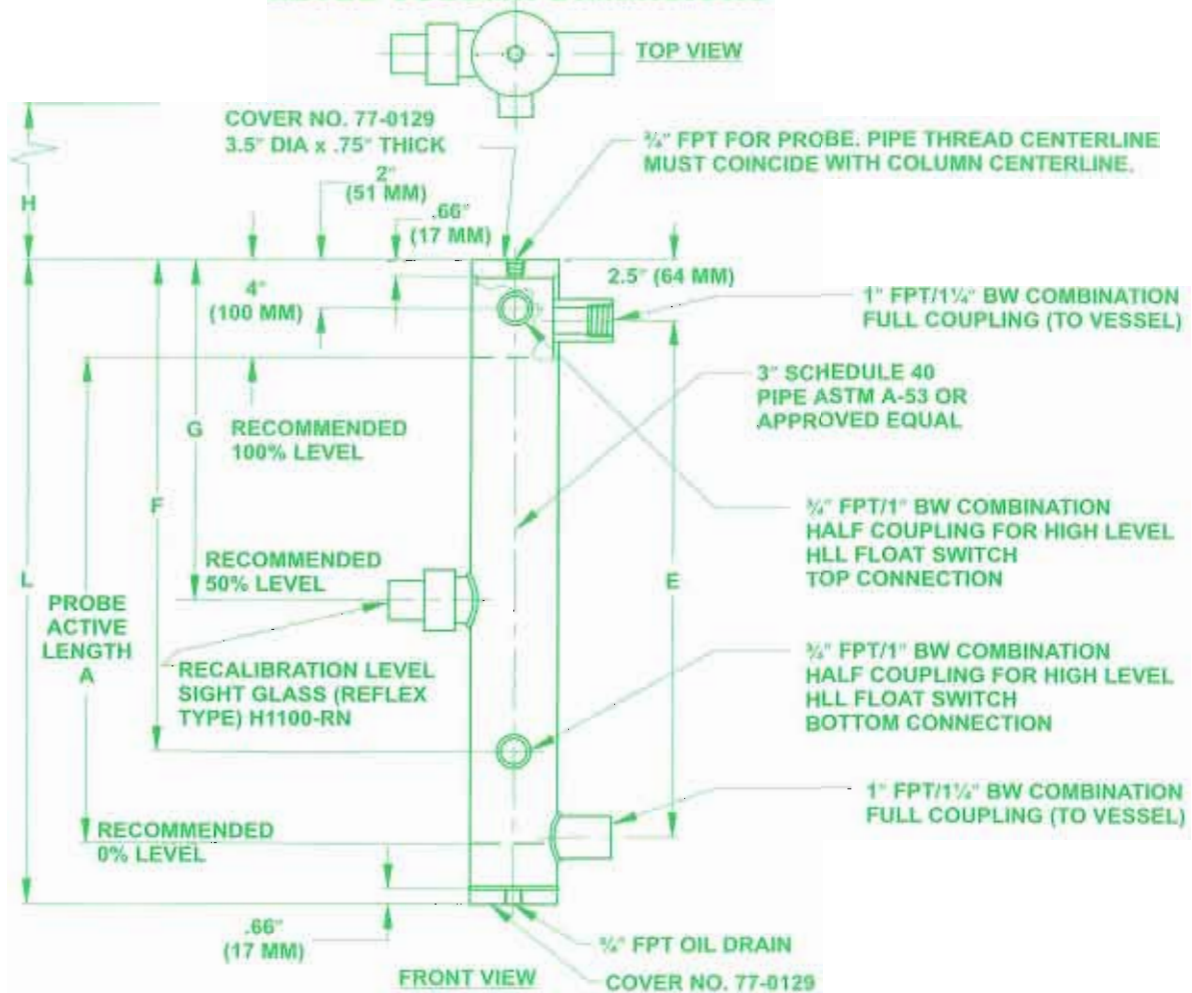

COMPLETE LEVEL COLUMN UP TO 120" (3050 MM) OR PARTS ARE AVAILABLE FROM HANSEN TECHNOLOGIES. PLUGS ARE SUPPLIED FOR THE OIL DRAIN AND FLOAT SWITCH CONNECTIONS.

CATALOG NUMBER	PROBE ACTIVE LENGTH A	EQUALIZER LEGS E	FLOAT SWITCH LEG F	SIGHT GLASS LOCATION G	PROBE REMOVAL HEIGHT* H	COLUMN OVERALL HEIGHT L
LC.02	20" 510 mm	21.25" 540 mm	18.50" 470 mm	14.00" 356 mm	40.00" 1015 mm	26.50" 673 mm
LC.03	30" 760 mm	31.25" 794 mm	31.13" 791 mm	19.00" 483 mm	50.00" 1270 mm	36.50" 927 mm
LC.04	40" 1015 mm	41.25" 1048 mm	36.13" 918 mm	24.00" 610 mm	60.00" 1525 mm	46.50" 1181 mm
LC.06	60" 1525 mm	61.25" 1556 mm	46.13" 1172 mm	34.00" 864 mm	80.00" 2030 mm	67.25" 1708 mm
LC.08	80" 2030 mm	81.25" 2064 mm	56.13" 1426 mm	44.00" 1118 mm	100.00" 2540 mm	87.25" 2216 mm
LC.10	100" 2540 mm	101.25" 2572 mm	66.13" 1680 mm	54.00" 1372 mm	120.00" 3050 mm	107.25" 2724 mm
LC.12	120" 3050 mm	121.25" 3080 mm	76.13" 1934 mm	64.00" 1626 mm	140.00" 3556 mm	127.25" 3232 mm
(For Field Construction)	144" 3660 mm	145.25" 3689 mm	88.13" 2239 mm	76.00" 1930 mm	164.00" 4166 mm	151.25" 3842 mm
(For Field Construction)	168" 4270 mm	169.25" 4299 mm	100.13" 2543 mm	88.00" 2235 mm	188.00" 4775 mm	175.25" 4451 mm

\*Add 3" (75 mm) for stainless steel extended neck version

## PROBE DIMENSIONS

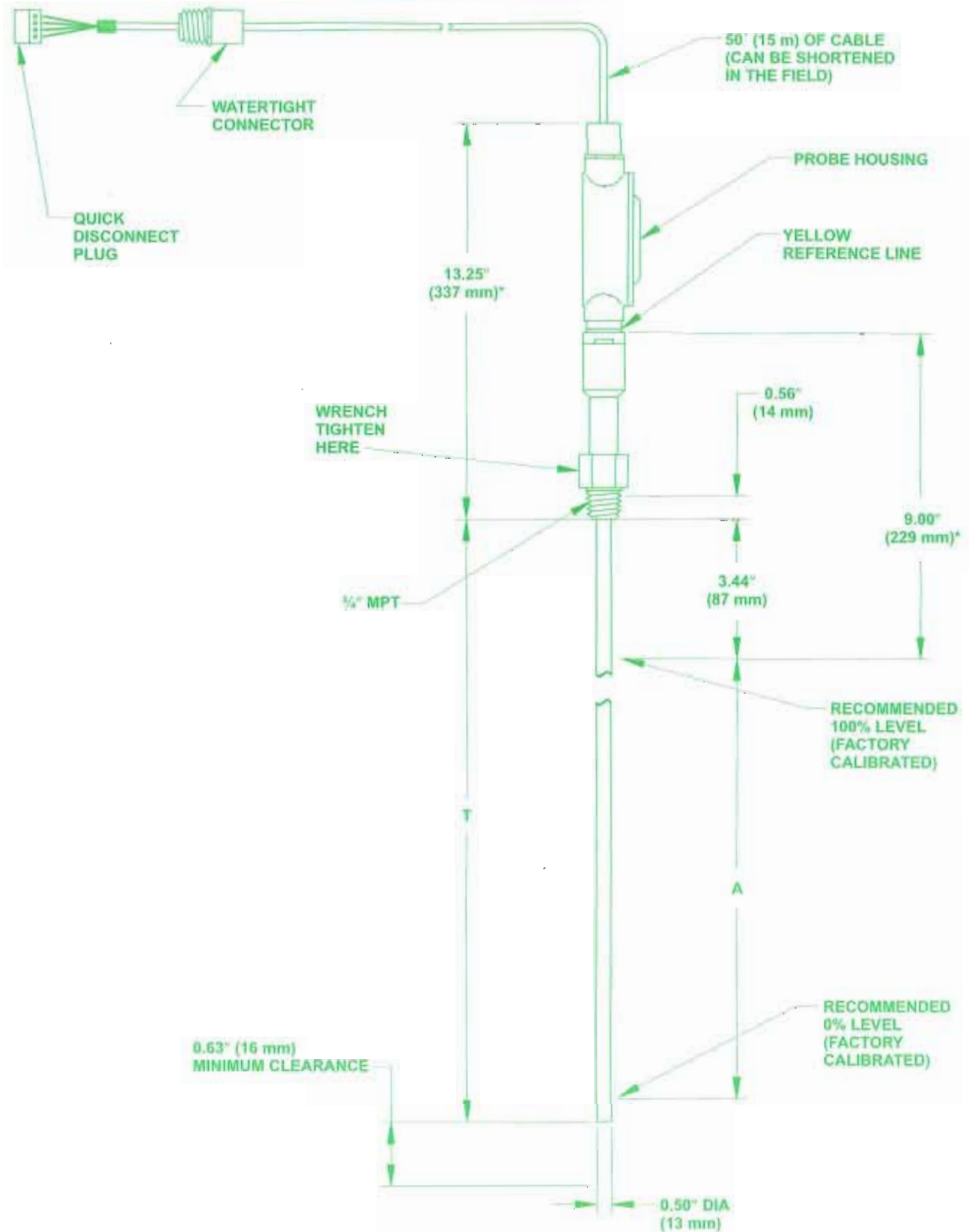

\*Add 3" (75 mm) for stainless steel extended neck version

A	20"	30"	40"	60"	80"	100"	120"	144"	168"
<b>(ACTIVE LENGTH)</b>	510 mm	760 mm	1015 mm	1525 mm	2030 mm	2540 mm	3050 mm	3660 mm	4270 mm
T	25"	35"	45"	65"	85"	105"	125"	149"	173"
<b>(INSERTION LENGTH)</b>	635 mm	890 mm	1140 mm	1650 mm	2160 mm	2670 mm	3175 mm	3785 mm	4395 mm

## WIRING OF RELAYS

Each control unit relay is individually protected by a replaceable 3 amp fuse (Hansen p/n 77-0206 or Bussman Fuse #PCC-3). Follow good electrical wiring practice and local codes when connecting any wiring. The wiring diagram on this page is one suggested approach to relay circuitry and is for illustration purposes only. Other methods are possible to meet specific control requirements. Refer to each manufacturer's wiring diagrams for proper wiring of controls. Before connecting relay circuits, the refrigeration system operation and design should be carefully reviewed. Final wiring details are the responsibility of the system designer.

Relays should be wired so that, in case of power failure, relay circuits will be in a safety mode for the refrigeration system. After being connected, the relay circuits can be checked by using the built-in simulator, as explained on page 5.

**NOTE:** The diagram below shows relays in the de-energized position (with no power to the control unit). With power to the control unit, control relays C, D, E will be energized when the level is at 0%. If there is a power failure or fault in the transformer on the control unit circuit board, all relays will go to the de-energized position.

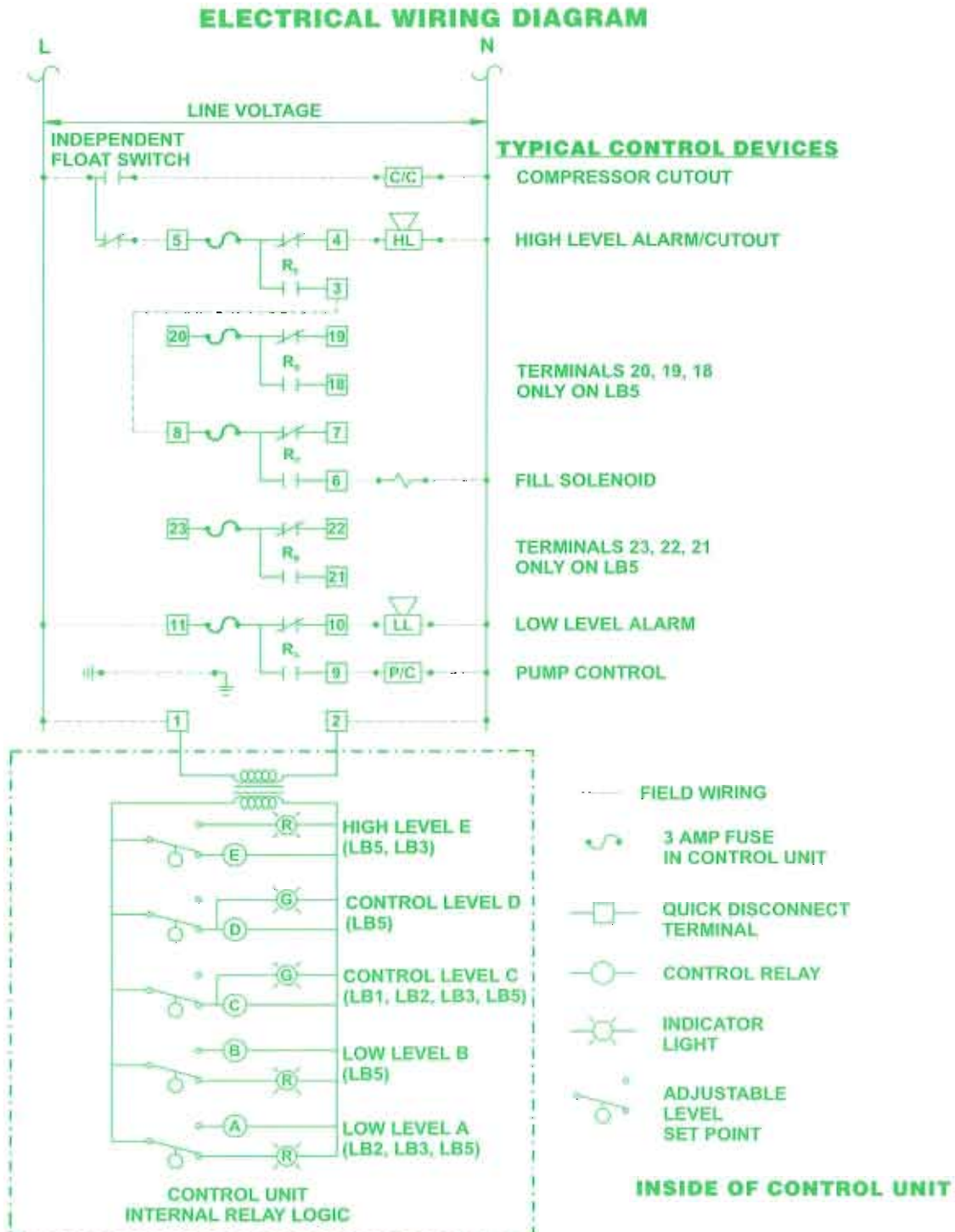

## PROBE WIRING DIAGRAM

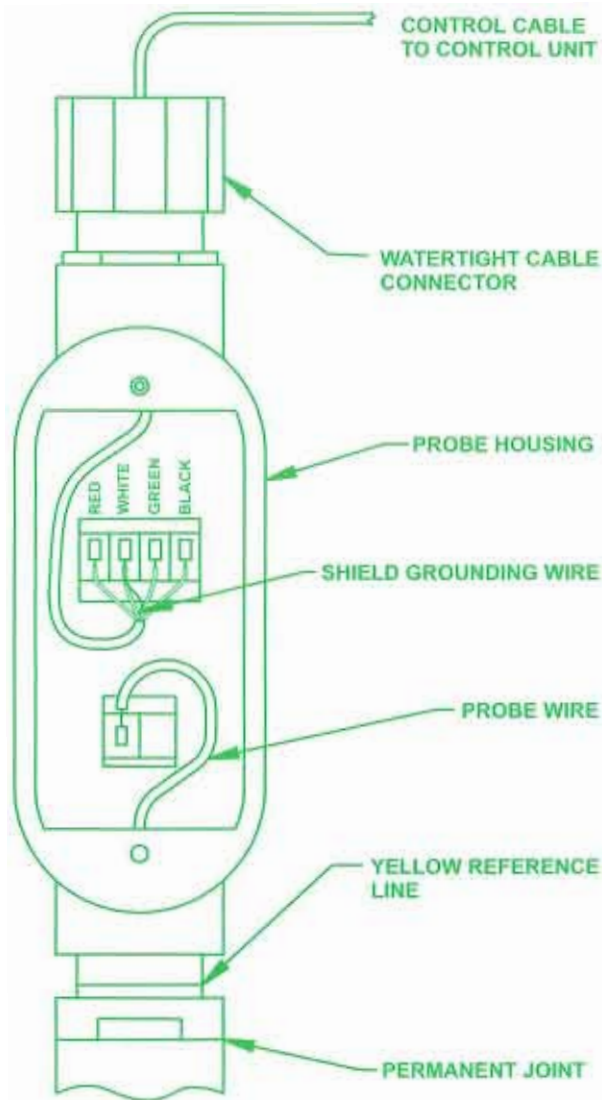

## OPTIONAL 4-20mA OUTPUT MODULE

The optional 4-20 mA output module (MOD420) provides a way to connect the Vari-Level® to a computer or other device for refrigerant level monitoring or control purposes. Primary level monitoring and relay control is still maintained at the control unit. However, if total computer control is desired, use Hansen Techni-Level® Transducer Probes having direct 4-20 mA output.

The MOD420 output module can be factory-installed and calibrated, or may be field upgraded. It is small enough to be easily added inside the standard control unit enclosure. See page 12 for example of MOD420 installed inside control unit. The output is electronically isolated to overcome interference with other transducers on the same power supply. Maximum load resistance is 1200 ohms. Required input voltage for MOD420 is 10-36V DC. The appropriate power supply unit (PSU) can be purchased from Hansen if needed.

If it is necessary to calibrate the MOD420, install an ammeter, digital readout or other device, as shown in diagram below. Enter simulation mode by depressing and holding the simulation mode button on the face of the control unit. Turn the level simulation adjustment screw until the digital readout displays 0%. While continuing to hold the simulation mode button, set the output current of the MOD420 to 4 mA using the Z (zero) calibration screw. Next, turn the level simulation adjustment screw until the digital readout displays 100%. Set the output current to 20 mA using the S (span) calibration screw. To confirm proper calibration, check for a 4 mA output at the 0% simulated level; a 12 mA output at the 50% simulated level; and a 20 mA output at the 100% simulated level. Adjust calibration if necessary. When the output is correct, return the simulated level to a percentage value between the control level and high level settings. This prevents alarms or cutouts from operating unexpectedly the next time the simulation mode is entered.

## 4-20 mA OUTPUT MODULE WIRING DIAGRAM

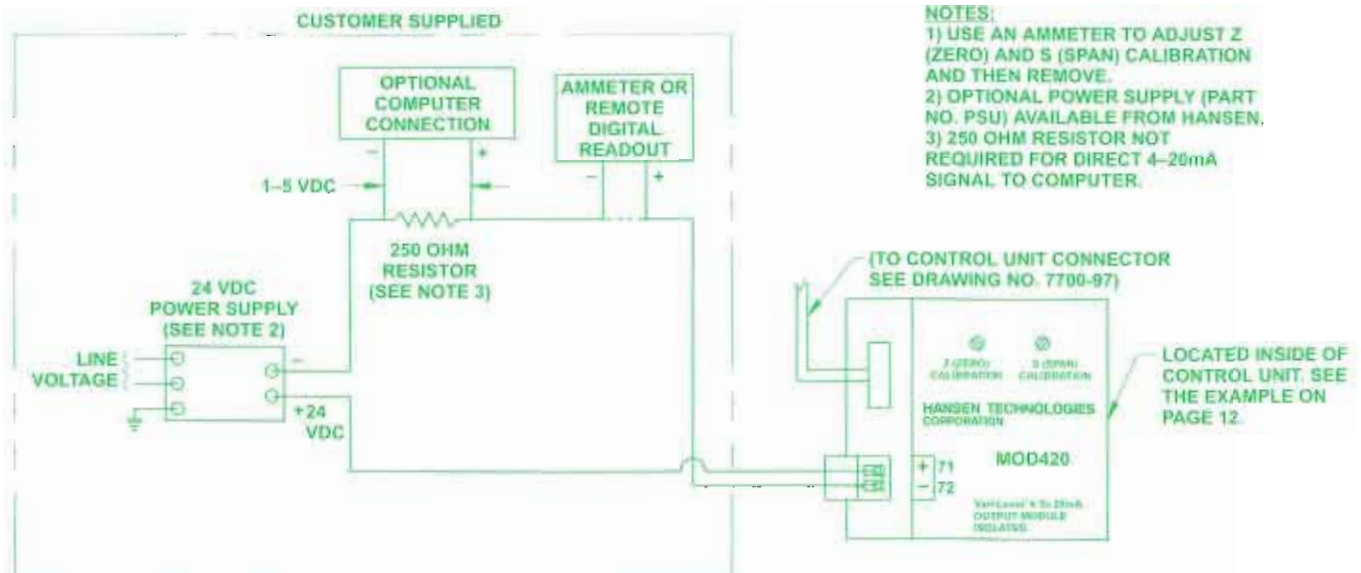

### NOTES:

- 1) USE AN AMMETER TO ADJUST Z (ZERO) AND S (SPAN) CALIBRATION AND THEN REMOVE.
- 2) OPTIONAL POWER SUPPLY (PART NO. PSU) AVAILABLE FROM HANSEN.
- 3) 250 OHM RESISTOR NOT REQUIRED FOR DIRECT 4-20mA SIGNAL TO COMPUTER.

## RECALIBRATION

Control units are accurately factory precalibrated to a 3" level column for the specified refrigerant and the supplied probe. **Control units should not normally need field recalibration.** However, the zero point and at least one other point (50% level or higher is best) should be checked at the operating refrigerant temperature for the highest level of accuracy. Probes installed in various other applications may require slight adjustment in calibration settings or precalibration in the field. It is ultimately the responsibility of the installer to ensure proper calibration for the specific application. If the control unit appears to be out of calibration, check for possible causes in the trouble-shooting guide on page 11 before attempting to change the calibration.

If recalibration is ever required, only two points need to be checked, typically the 0% and sight glass % level points (normally at the 50% level point, but other levels possible). Recalibration must be done in the order specified below.

To check the proper calibration at the 0% level, the level column should be free of liquid to below the probe bottom end. This can be accomplished by closing the valve in the upper equalizer line while the valve in the lower equalizer line remains open. It may take several minutes for the warmer vapor in the column to push the liquid surface down below

the probe. With the probe end free of liquid, the control unit's digital readout should display -00%. If not, remove the seal on the low level calibration screw and adjust with a small screwdriver until the readout indicates -00%; replace seal.

Hansen level column standard sight glass location is at 50%. To check the sight glass % level, some basic calculations need to be made. See the diagram below. Add 9" to the factory-stated probe Active Length (A) and measure this distance down from the yellow reference line. This will be the 0% level point on the outside of the level column, which is normally the bottom of a horizontal vessel. Measure up from this point to the center of the sight glass and divide by the desired active length (usually the factory-stated active length). This is the percentage at which the sight glass is located. Raise or lower the liquid level so that it is centered in the sight glass. The digital readout on the Vari-Level® control unit should display the same level as the calculated sight glass % level. If not, remove the seal on the high level calibration screw and adjust until the digital readout displays the calculated sight glass % level; replace seal. For greatest accuracy, recheck 0% calibration and readjust if necessary.

Recalibration may be necessary when a replacement probe or control unit is installed, especially if not "factory matched" by serial number.

## NORMAL FACTORY-SET CALIBRATION LEVELS

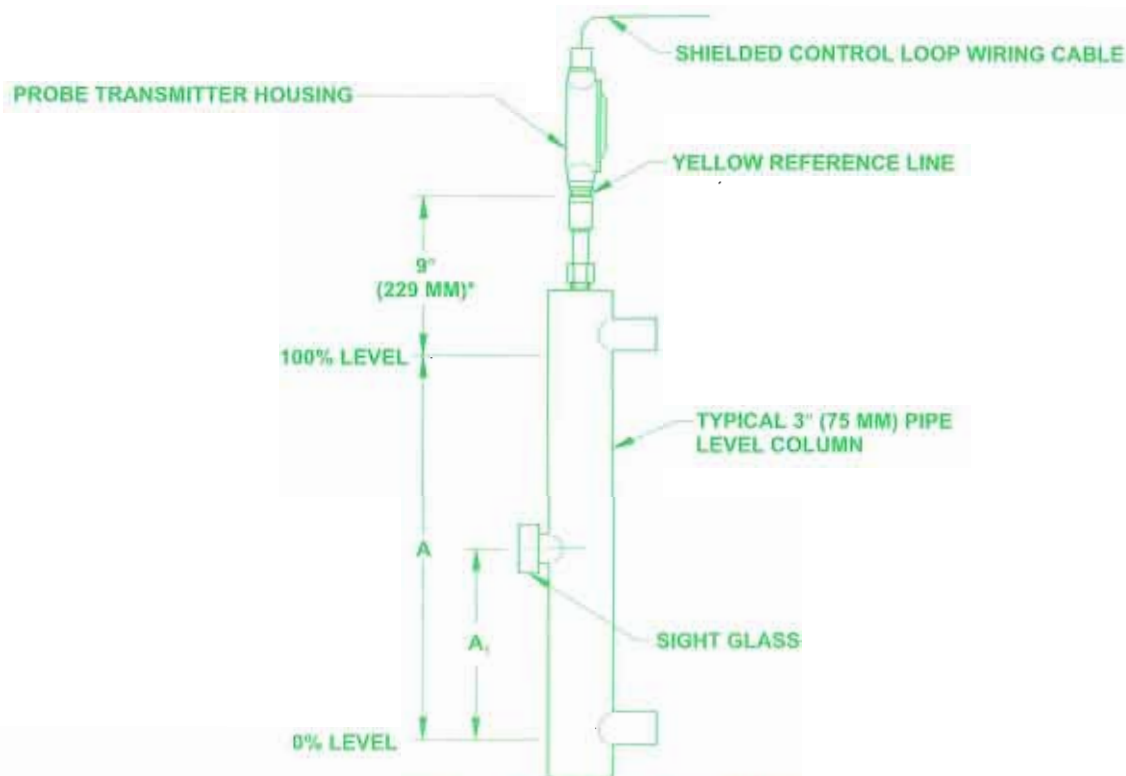

Calibration point 0% Level = 9" (229 mm) + Active Length (A) below yellow reference line

Calibration point Sight Glass % Level =  $\frac{A_s}{A}$

\*Add 3" (75 mm) for stainless steel extended neck version

## TROUBLE-SHOOTING

PROBLEM	CAUSE	ACTION
Digital readout and indicator lights do not display.	A. No power to control unit or wrong voltage. B. Moisture in control unit or probe housing.	A. Check voltage at terminals 1 and 2 in the control unit. B. See Note 1 below.
Digital readout does not indicate level changes.	A. Fault in control cable. B. No continuity between probe and level column. C. Moisture in control unit or probe housing. D. Equalizer valves closed. E. Probe wire loose. F. Equalizer lines clogged with oil or debris. G. Poor pipe connection between level column and vessel.	A. See Note 2 below. B. Verify that nonelectrically isolating pipe thread sealant is at the probe-to-column connection. <b>Do not use Teflon<sup>®</sup> tape.</b> C. See Note 1 below. D. Open valves. E. Open probe housing cover and check connection of probe wire (signal wire lead) from probe center to terminal connection. F. Remove oil and debris from equalizer lines and level column. G. Check valve locations and orientation.
Control devices do not operate (i.e. solenoid valves, control relays, etc.).	Blown fuse in control unit. Fuses located just above quick disconnect terminal strip.	Find reason for electrical fault and correct. Replace blown fuses (Hansen p/n 77-0206, or Bussman #PCC-3).
Digital readout indicates too low of a level compared to sight glass.	A. Control unit and probe serial numbers do not match. B. Fault in control cable. C. (Ammonia only) Oil in level column. D. (R22 only) Oil rich mixture in level column. E. Moisture in control unit or probe housing. F. Calibration not correct. G. Calibrated for different refrigerant. H. Column is not standard 3" dia. I. Insulating resistance of Teflon <sup>®</sup> -enclosed probe rod is too low. J. Refrigerant temperature significantly different from calibration temperature.	A. Contact factory if mate is not available. B. See Note 2 below. C. Remove oil from level column. Also see page 3 for recommended level column piping. D. Remove oil from level column periodically or incorporate an "oil skimmer" or bleed connection. E. See Note 1 below. F. See recalibration instructions on page 10. G. Contact factory for replacement. H. Slight recalibration may be required. I. See Note 3 below. J. Recalibrate at operating temperature.
Digital readout indicates too high of a level compared to sight glass.	A. Control unit and probe serial numbers do not match. B. Fault in control cable. C. Moisture in control unit or probe housing. D. Liquid boiling inside level column. E. Calibration not correct. F. Calibrated for different refrigerant. G. Column is not standard 3" dia. H. Refrigerant temperature significantly different from calibration temperature.	A. Contact factory if mate is not available. B. See Note 2 below. C. See Note 1 below. D. Insulate the level column. E. See recalibration instructions on page 10. F. Contact factory for replacement. G. Slight recalibration may be required. H. Recalibrate at operating temperature.
Intermittent high level.	A. Rapid suction pressure pull down results in bubbling and surging liquid. B. High level alarm set point has been positioned too close to operating set point. C. Moisture in control unit or probe housing.	A. Alter compressor loading sequence, defrost sequence, or liquid make up feed time to "reduce" pressure fluctuations in vessel. B. Lower operating set point or raise high level set point. C. See Note 1 below.
Occasional erratic level displayed on digital readout without actual changes in level.	A. Moisture in control unit or probe housing. B. Radio Frequency Interference (RFI). C. High voltage power wiring, motors, starters, etc. near control box or probe.	A. See Note 1 below. B. Find source of interference, such as mobile radios or other transmitters, and disable. Make sure shielding wire is grounded. Do not loop excess wire. Shorten to required length. C. Relocate control box or high voltage power wiring a minimum of 3 feet (1 m) away.

**Note 1:**

**MOISTURE IN CONTROL UNIT OR PROBE HOUSING.** Dry out control unit or probe housing. If appearance is dry, look for signs of moisture damage, such as white residue. Check cover gaskets, watertight cable connectors, and other water sealing joints, replace if worn. If a conduit connection is on top of the probe, carefully seal the inside to prevent condensation migration into the housing. Relocate any conduit connections on top of the control unit to the bottom, or seal the connections.

**Note 2:**

**FAULT IN CONTROL CABLE.** A symptom can be the digital readout display above 100% or below 0%. Check wires and matching color dots on quick disconnect plugs at the

probe and control unit for proper connection. See page 9 for probe wiring diagram. Wires should be securely fastened and not frayed. Also check for continuity in the wiring.

**Note 3:**

**INSULATION VALUE OF PROBE.** The following procedure is only required if probe integrity is questioned. With the probe wire removed from its socket, check the insulating resistance of the Teflon<sup>®</sup>-enclosed probe rod using a 500V "Megger". Connect the positive side to the probe wire, the negative side to the probe housing. The result should be over 1000 Mega Ohms; halocarbon probes should be over 50 Mega Ohms. If not, contact the factory.

## CAUTION

Hansen Vari-Level® controls have been designed for refrigeration systems. These instructions and related safety precautions must be completely read and understood before selecting, using, or servicing these controls. This is an operating control, not a safety control. Only knowledgeable, trained refrigeration mechanics should install, operate, or service these controls. Stated temperature and pressure limits should not be exceeded, and all electronics should be protected from moisture. Probes should not be removed from level columns unless the system has been evacuated to zero pressure. Escaping refrigerant may cause injury, particularly to the eyes and lungs.

Vari-Level® controls are intended to be an operating device only. Therefore it is recommended that a high level float switch cutout be installed whenever practical. This provides a nonadjustable safety in case of an accidental, incorrect high level setting or failure of a high level control relay or interface device.

**WARNING:** As with all electronic and mechanical components, there is a limited life expectancy. An expected life of seven to ten years is typical. This should be understood as only a suggested replacement time period. Actual condition and performance of electronics due to ambient conditions, quality of electrical current, voltage, etc., may necessitate a different replacement schedule. Regardless, probes and control units should be inspected at least annually to ensure their safe and continuous service. See also Safety Precautions in current List Price Bulletin and Safety Precaution Sheet supplied with product.

## WARRANTY

Hansen Vari-Level® electronics are guaranteed against defective materials or workmanship for 90 days F.O.B. factory. All other Vari-Level® components are guaranteed for 1 year F.O.B. factory. No consequential damages or field labor is included.

## CONTROL UNIT

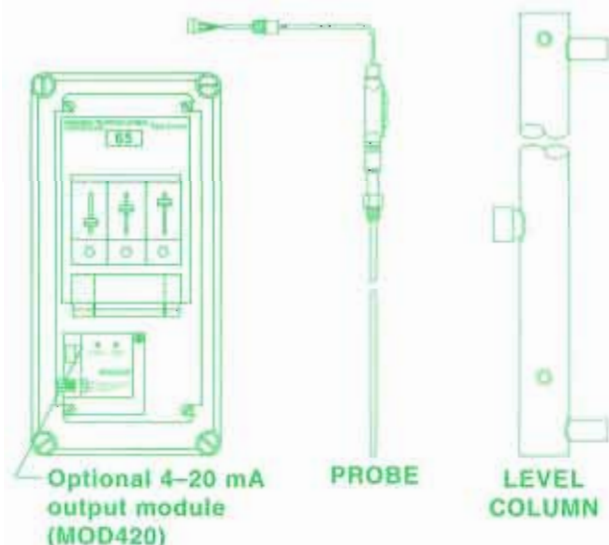

## ORDERING INFORMATION

CONTROL UNIT (LESS PROBE)		
RELAYS	CONTROL POINTS (TYPICAL)	CAT. NO.
3	Control, Low, and High Level	LB3
2	Control and Low Level	LB2
1	Control Level	LB1
5	Control (2), Low (2), and High Level	LB5
OPTIONS		
*4-20 mA Output Module		MOD420

\*A 115VAC/230VAC: 24VDC power supply unit is available to power the 4-20mA circuit. Specify part number PSU if needed.

ACTIVE LENGTH*	PROBE CAT. NO.	LEVEL COLUMN CAT. NO.
20" (510 mm)	LP.02	LC.02
30" (760 mm)	LP.03	LC.03
40" (1015 mm)	LP.04	LC.04
60" (1525 mm)	LP.06	LC.06
80" (2030 mm)	LP.08	LC.08
100" (2540 mm)	LP.10	LC.10
120" (3050 mm)	LP.12	LC.12
144" (3660 mm)	LP.14	**
168" (4270 mm)	LP.16	**

\*Custom probe lengths up to 168" (4270 mm) maximum and custom column lengths up to 120" (3050 mm) maximum are available; contact the factory for details.

\*\*Customer supplied, not available from Hansen.

**TO ORDER:** Specify control unit catalog number, voltage, refrigerant, probe catalog number with Active Length, and level column catalog number if required. Custom lengths are available at an additional cost, but may take longer to manufacture and are nonreturnable.

## TYPICAL SPECIFICATIONS

"Adjustable refrigerant liquid level controls shall have solid-state electronics, digital readouts, level set point and differential adjustments, Teflon® enclosed stainless steel probe rods and be suitable for refrigeration environments. Level controls shall be "Vari-Level®" as manufactured by Hansen Technologies Corporation or approved equal."

## OTHER HANSEN LEVEL CONTROLS

Techni-Level® Transducer Probes (4-20 mA); VLT Receiver Transducer Probes (0-5V, 1-6V); SVP, SHP Refrigerant Float Switches (HLL, HLLS) Single Point Level Sensors (SPL, SPS) Float Drain Regulators (High Side Floats and Defrost Drainers) Level Pulse Control System (LPS)

## HANSEN TECHNOLOGIES CORPORATION

6827 High Grove Boulevard  
Burr Ridge, Illinois 60521 USA  
Telephone: 630-325-1565  
Toll-free: 800-426-7368  
FAX: 630-325-1572  
E-mail: info@hantech.com  
Web Site: www.hantech.com