

# AUTO-PURGER® M

“ENERGY SAVER”

Compact, Non-Condensable Gas (Air) Refrigerant Purger

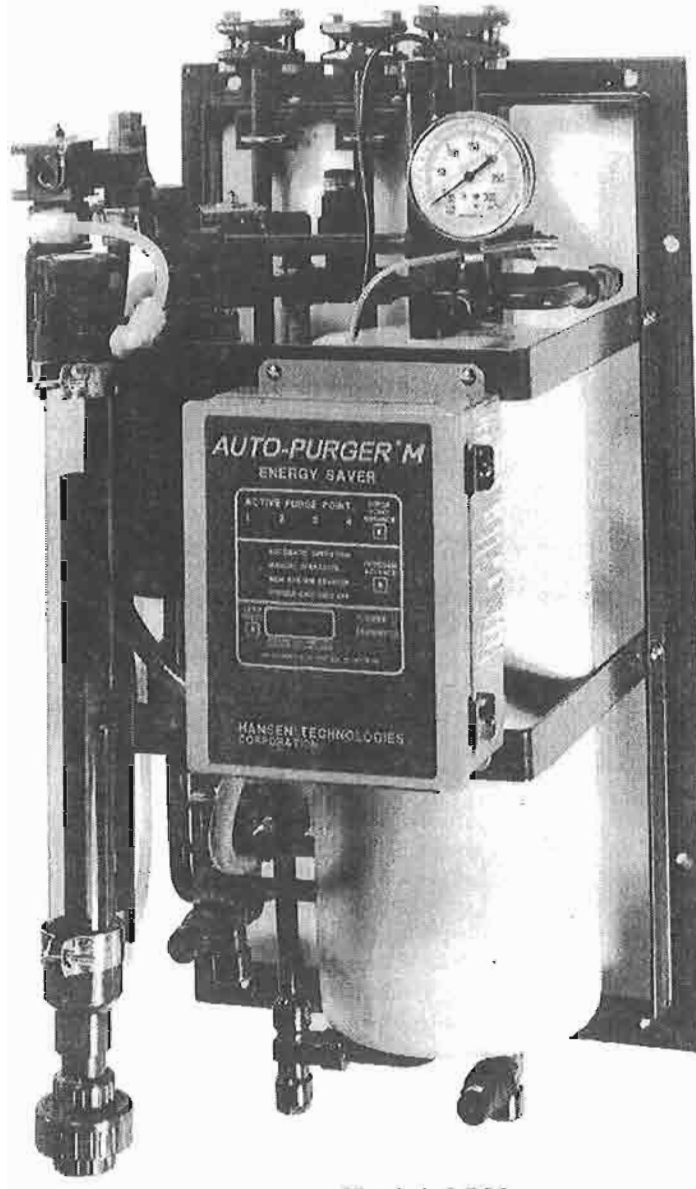

Model APM



## OPERATOR INSTALLATION & INSTRUCTION MANUAL

For 115V and 230V Models

## SECTION I MOUNTING & PIPING INSTALLATION

### INTRODUCTION

The AUTO-PURGER® M is a compact and totally automatic, electronically-controlled, non-condensable gas refrigerant purger for reducing condensing pressure and thereby saving electrical energy consumed by the refrigeration system. This deluxe purger is pre-assembled, pre-wired, tested, insulated and includes an automatic water bubbler. Installation requires piping the "foul gas" line, liquid line, suction line, water line, drain line, and wiring the power connection and the remote 1/2" (13 mm) port purge point solenoid valves, which must be purchased separately. Up to four (4) purge points can be controlled by this purger. The AUTO-PURGER® M (hereafter referred to as APM) features welded piping and watertight electrical construction. The APM meets the requirements of the Canadian Standards Association (CSA certified).

A typical APM installed in a plant with normal entering non-condensable loads will handle up to a 200 ton (700 kW) ammonia system. Each purge point will be active between 10 and 30 minutes, depending on non-condensable gas presence (mostly air) and purger mode operation.

### MOUNTING INSTRUCTIONS

Mount the APM straight and securely on a wall or sturdy steel channels. Eight mounting holes in the frame are provided to support the purger (See Figure 1). The APM should be located in an accessible area, but away from the movement of equipment that could accidentally damage the purger. Elevation with respect to condensers or high pressure receivers is not critical.

An APM is usually installed in the compressor room where it can be monitored, but also may be installed outdoors where temperatures below freezing are not anticipated. APM comes standard with a watertight NEMA 12,13 (IP55, IP65) control cabinet enclosure with sealed conduit wiring. Any unused electrical entrances to the enclosure must be sealed to protect electronics from moisture.

An optional valve package (VPM) for purger isolation is available from Hansen. It consists of three welded assemblies which include shut-off valves, gauge valves and mating flanges. An illustration detailing this optional valve package is on page 12 (Figure 12).

### INSTALLATION DIMENSIONS INCHES (mm)

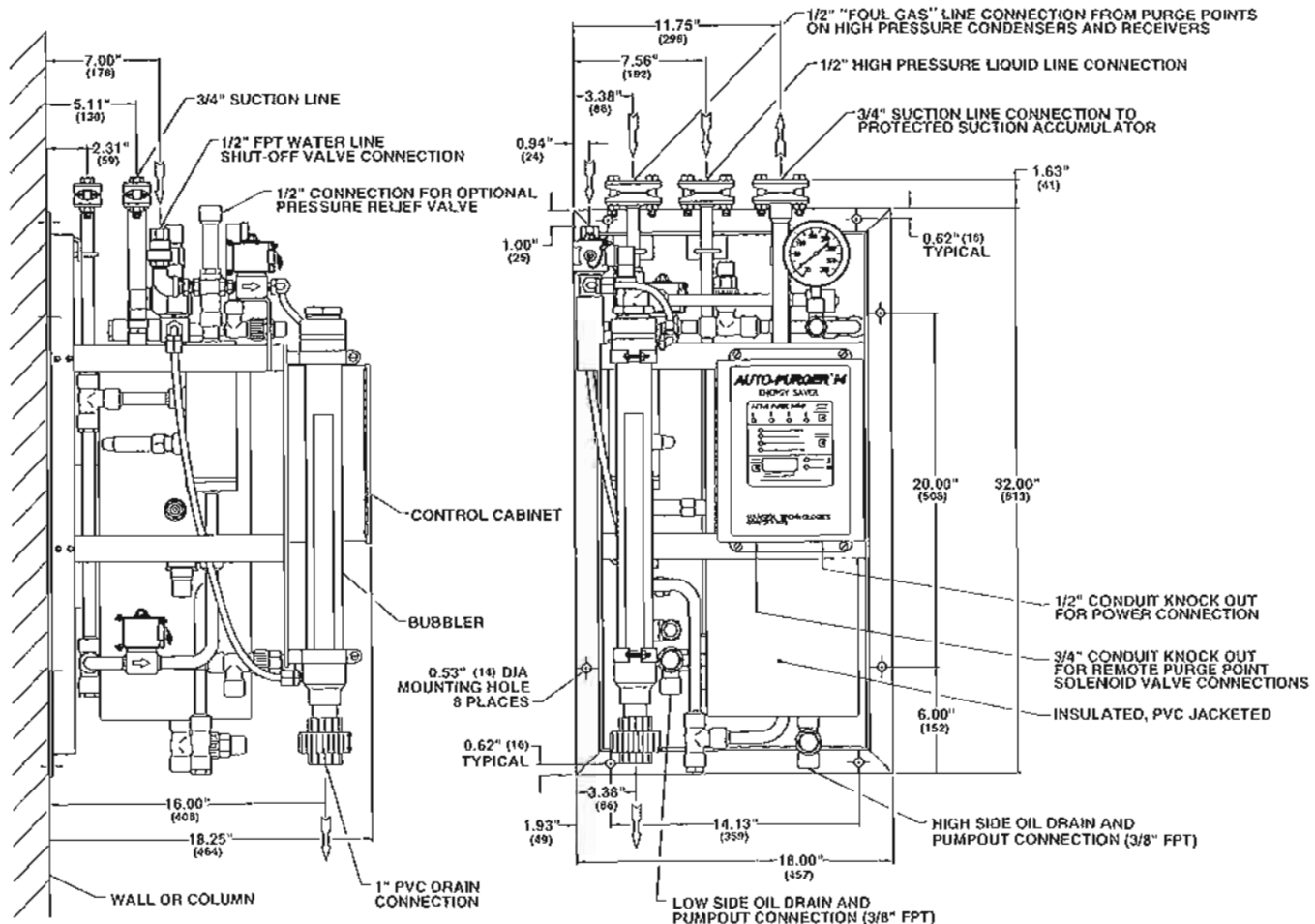

Figure 1.

### "FOUL GAS" PIPING

Purging at several points, up to four with the APM, on the high pressure side of the system is the best method for removing "foul gas" which is refrigerant gas containing some air or other non-condensibles. This is because it is nearly impossible to predict every point where non-condensable gas will accumulate in a system.

Even for multi-point purging, only one purge point should be purged at a time. Connecting two purge points from two condensers or receivers may result in gas flowing from one condenser to another due to unequal pressure drop, even though the differences in pressure drop are very small, for example 1/4 psig (0.02 bar). The result would be, that even in the best of circumstances, only one point would be effectively purged. The best practice is to purge each condenser and receiver circuit separately.

When utilizing multi-point purging, the purge point solenoid valves can be manifolded into one "foul gas" line to the purger. A 1/2" size line is the minimum and should be pitched towards the purger to drain any condensed liquid. Also, no liquid traps are allowed either before or after purge point solenoid valves (See Figure 2). The "foul gas" line should not pass through cold areas where further condensing of the saturated gas can occur. If this cannot be avoided, the line must be insulated because flooded purge point lines result in flooding the APM with liquid, causing a temporary halt of non-condensibles

being removed. If flooding can not be avoided, additional condensate drainage may be necessary.

It is important that all purge points be located above any liquid surfaces to avoid drawing liquid refrigerant rather than vapor into the APM.

### EVAPORATIVE CONDENSER PIPING

Typically, evaporative condenser outlet liquid drain lines on each circuit must drop a minimum of 4 feet (1.2 m) for ammonia from the center line of the evaporative condenser outlet to the center line of highest elevation of the liquid line manifold to receiver. Preferably each circuit should have a P-trap to balance variations in pressure drop in each circuit to prevent liquid from backing up into one or more condensers and thereby flooding the purge point. **Most air from the system will normally be trapped between the condenser and the P-trap.** Also, a properly sized equalizer line from the receiver will help drain condenser circuits into the receiver. Refer to ASHRAE GUIDELINES or IIR Papers on condenser piping design. Hansen Technologies can provide copies of these articles. Also, consult condenser manufacturers' installation instructions for additional piping and sizing information.

On evaporative condensers, avoid using one purge point solenoid valve to purge two circuits. This practice negates the P-trap on the condenser drain line because of the purge connections of the two circuits and may back liquid up into one circuit.

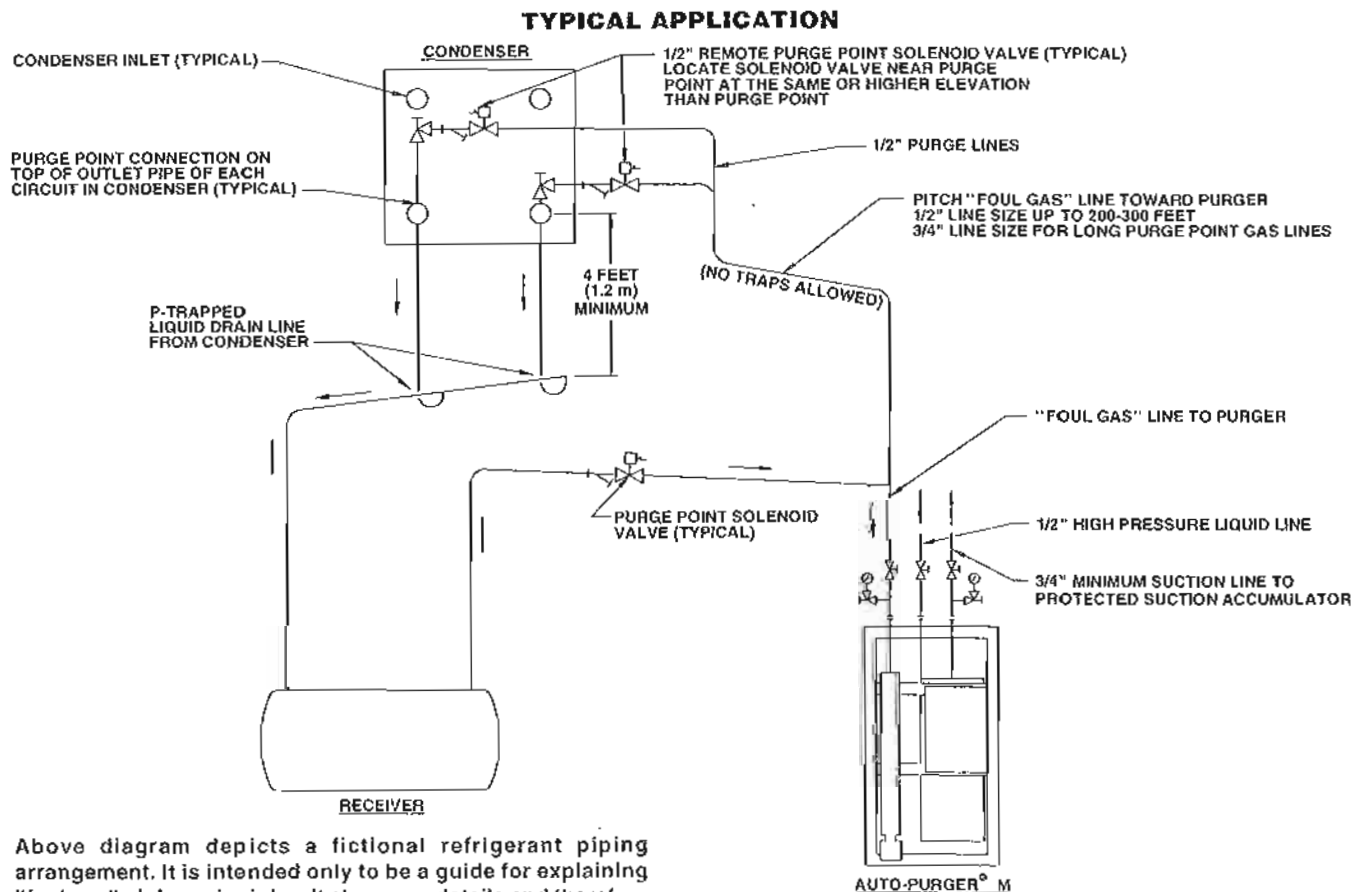

Above diagram depicts a fictional refrigerant piping arrangement. It is intended only to be a guide for explaining "foul gas" piping principles. It shows no details and therefore should not be used for construction.

Figure 2.

## PURGE POINT CONNECTIONS

"Foul gas" lines from condensers should be purged at points recommended by the condenser manufacturer. Usually, this is at the top of each circuit's outlet header which drains down through a p-trap to the receiver. In some cases, a small high pressure auxiliary receiver is located at the outlet of one or more condensers. This receiver should have a purge point at the top, preferably at a "dead" area away from condenser drain pipes. Below is a typical valve arrangement for a purge point (Figure 3). **Regardless of the purge point location, it is absolutely necessary to ensure that liquid is not drawn into the foul gas line.**

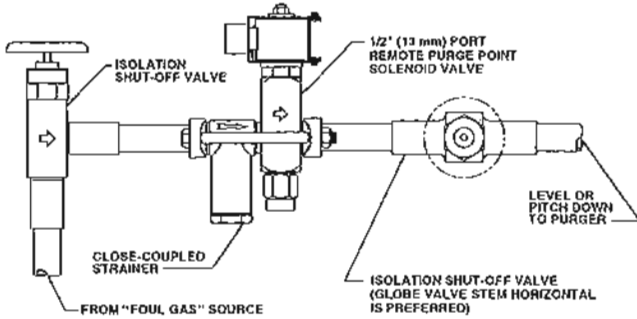

Figure 3.

Where a high pressure float regulator is used to drain one or more condensers, the top of the float valve chamber should also be a purge point.

Horizontal shell and tube water-cooled condensers, and heat exchangers should be purged at the top, usually at the point or points furthest from the compressor discharge main inlet.

Vertical condensers should be purged near the top of the vessel if possible.

For certain types of oil separators where very low velocities may exist near the top of the vessel, purging may be advisable from a top fitting.

It is normally not advisable to purge controlled pressure receivers, high pressure thermosyphon vessels, or vessels located on the low side of the system.

## SUCTION LINE

The  $\frac{3}{4}$ " suction line from the purger should be connected to a protected main suction line or a suction accumulator. Install suction line isolation shut-off valve near purger. Excess amounts of liquid from the purger evaporator may occasionally be transmitted through the suction line. The suction temperature must be 40F (4.4°C) or less to satisfy APM temperature sensor before purging will occur.

## LIQUID LINE

A high pressure  $\frac{1}{2}$ " liquid line is required for the APM. The connection to the high pressure liquid source should be a location where oil would not be directed into the purger. Install liquid line shut-off valve near purger. The liquid line supplies refrigerant during startup and feeds make-up liquid as required. The only requirement is the liquid supply pressure

must be sufficiently above the purger evaporator pressure, usually greater than 60 psi (4.1 bar). During operation, only 5% of the liquid refrigerant required for cooling comes from the liquid line. The remainder of the refrigerant is condensate from the "foul gas" line, which is collected in the drain, condensed in the coil, and into the evaporator.

## WATER LINE

The APM has an automatic water bubbler to eliminate any water bottle attention. Connect water supply to the purger water shut-off valve (See Figure 1). Water pressure should be between 30 and 80 psig (2 and 5 bar). The factory installed flow controller limits the amount of water going into the bubbler.

The transparent tube of the water bubbler may become coated with mineral deposits after a period of time. These deposits can be removed by adding a cup of vinegar to the water in the bubbler and cleaning the clear tube through the top plastic fitting with the brush supplied. A water conditioning filter cartridge and housing are available for abnormally hard water.

## DRAIN LINE

A 1" PVC socket water drain connection is located at the bottom of the bubbler (an alternate 1" FPT threaded adapter is also supplied). The water should flow to a suitable drain. Initially, fill water bubbler with water via the threaded plug located at the top of the bubbler. Keep plug lubricated and hand tight. A circular thin plastic stick-on acts as a bubbler relief device in case of water drain plugging. The drain line should be supported to prevent undue stress on water bubbler.

## OIL DRAINS

There are two  $\frac{3}{8}$ " valve oil drain connections near the bottom of purger (see Figure 1) from which oil can be drained. These valves are fitted with  $\frac{5}{16}$ " (8 mm) socket plugs. Before draining oil, first close the liquid and "foul gas" lines to prevent additional liquid from entering the purger. Wait approximately one half hour and then turn the purger off. Allow purger to pump out, then close the suction line shut-off valve. Use normal refrigerant oil draining precautions to prevent human or property damage. In general, oil will not be a problem unless the liquid line is connected to a vessel or line where oil can enter the purger. See also Caution section on page 12. Escaping refrigerant might cause personal injury, particularly to the eyes and lungs.

## LEAK TEST

Use standard refrigeration procedures to check APM for leaks before placing it into service. See also Caution section on page 12. Manually open one purge point solenoid valve. Open the "foul gas" line shut-off valve and wait a few moments for the flooded evaporator to pressurize through metering orifice. Allow pressure to build to condensing pressure as shown on the high side pressure gauge. Close "foul gas" line shut-off valve and check purger for leaks.

## SECTION II ELECTRICAL INSTALLATION & OPERATION

### ELECTRICAL CONNECTIONS

The standard electrical requirement for the APM is 115V 50/60 Hz; also available is 230V 50/60 Hz. The control cabinet has a bottom 1/2" knockout for power connection and bottom 3/4" knockout for individual purge point solenoid valves (See Figure 4). Any additional knockouts, if necessary, should be made on the bottom of the control cabinet. A grounding block inside the control cabinet is provided for 3-wire purge point solenoid coils. Carefully study the wiring diagram below (Figure 5) to avoid electrical short circuits.

Connect electrical wiring from each purge point solenoid to remote purge point solenoid plug-in connector screw terminals (1 through 8) plus the grounding block. Normally the voltage of the remote purge point solenoid valves is the same as the purger. However, if purge point solenoid valve coil voltage is different, simply remove and discard factory installed jumpers between terminals 13 & 14 and 15 & 16. Bring purge point solenoid line (L1) connection to terminal 14 and neutral (L2) to terminal 16.

### CONTROL CABINET (INSIDE VIEW)

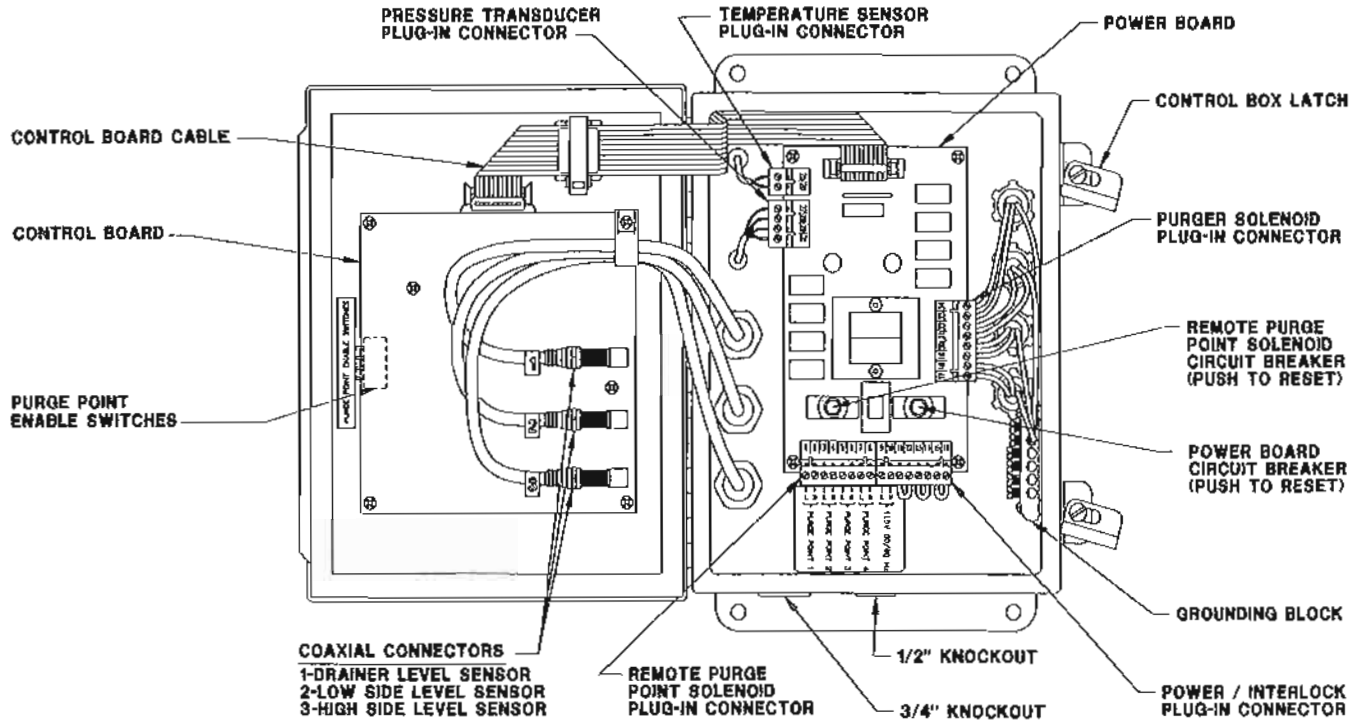

Figure 4.

### WIRING DIAGRAM

#### POWER BOARD

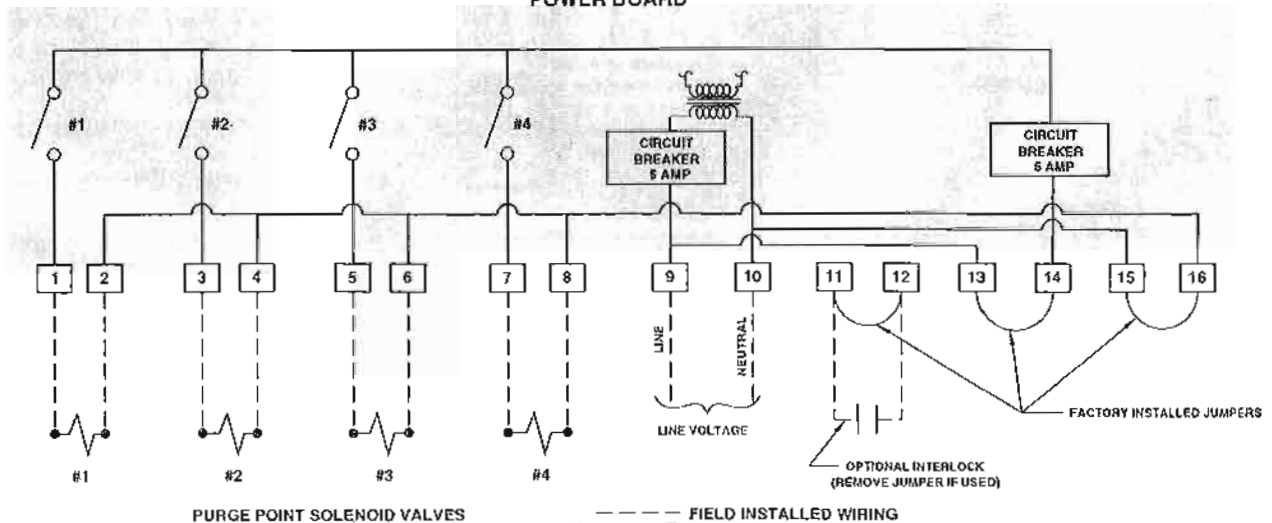

Figure 5.

## FEATURES OF THE APM

The purger can be set to one of several modes of operation to suit the requirement of the system. These include: Automatic Operation, Manual Operation, New System Startup, and Purgers Switched Off. The mode of operation can be selected by repeatedly pushing the program advance button on the front panel until the desired purger mode light is on. (See Figure 6).

## AUTOMATIC OPERATION

The Automatic Operation mode is where the purger should be set when normal levels of non-condensibles are in the refrigeration system. The microprocessor-based electronics of the APM uses its "logic" to locate non-condensibles and spend more time purging those points. The purger will energize the first enabled purge point solenoid (see page 7, Purge Point Enable Switches). If after 10 minutes passes, non-condensibles are not released, purger then will advance to the next enabled purge point. If non-condensibles are released at any purge point within the first 10 minutes, then the purger will continue to process gas and remain at that purge point for increments of 10 minute time periods as long as non-condensibles are released during the 10 minute time period. This "smart" feature will continue for a maximum of 30 minutes. After 30 minutes, the purger will go on to the next active purge point regardless if non-condensibles are released. Once non-condensibles have been minimized, and enabled purge points cycle without releasing non-condensibles, the purger will go into "Standby" mode for two hours (the Standby purger status light will be on). After two hours on Standby, the purger will then resume operation to seek out non-condensibles that may have collected.

## MANUAL OPERATION

Manual Operation mode allows the operator to select one purge point continuously. This is usually the case if a large volume of non-condensibles is suspected to be at a particular point. To select this mode, push program advance button until the Manual Operation purger mode light is on. Then push purge point advance button to select the purge point. In this mode, the purger will purge this point only. However, non-condensibles must be present for purger to release gas from the purger. If not, purger will go into Standby mode.

## NEW SYSTEM STARTUP

The New System Startup mode is to be used when the refrigeration system is known to contain large amounts of non-condensibles gas. This may be due to new system startup, extensive repairs to a system, or the presence of an abnormal vacuum leak on the low side of the system. The APM automatically sequences the purge point solenoid valves for a fixed period of 10 minutes each to remove air from each of the enabled purge points. Purgers will not go into Standby mode while in New System Startup mode.

## PURGER SWITCHED OFF

When the purger is in this position, all solenoid valves close and the purger will pump out if the suction valve is open.

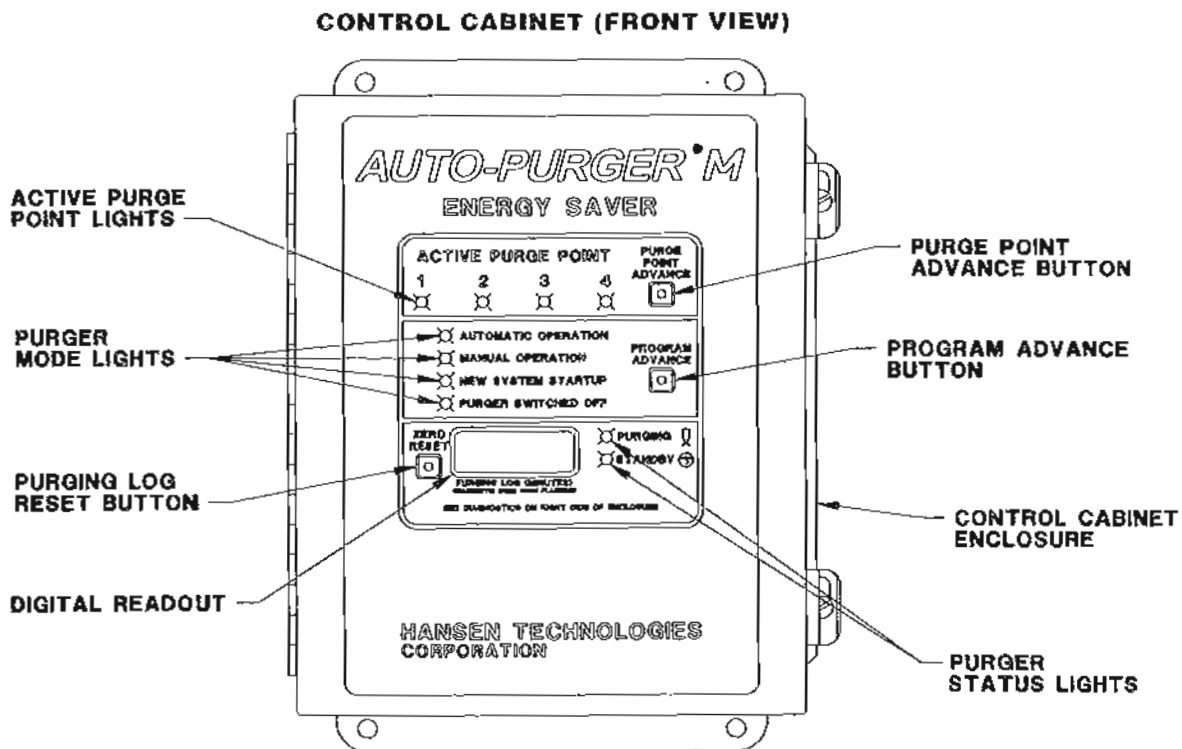

Figure 6.

### ACTIVE PURGE POINT

The front of the control cabinet has lights which indicate the active purge point. The active purge point can be manually advanced in any operational mode by pushing the purge point advance button.

### PURGER STATUS LIGHTS

There are two purger status lights on the front of the control cabinet next to the digital readout. These are the Purger status light and Standby status light which indicate when non-condensable gas (air) is being released from the purger (Purging); or indicate when the purger is in a waiting mode (Standby).

### PURGING LOG

The purging log is displayed on the digital readout. It displays the number of minutes the purge gas solenoid valve (C) has been open to release non-condensibles into the water bubbler.

The purger log can be used to track the release of non-condensable gas. If a daily or weekly record is kept, then any abnormal increases in the amount of non-condensable gases can be noted, and corrective measures can be taken. Little or no activity compared to normal operation may indicate non-condensibles have been thoroughly removed or a problem with the purger. Frequent activity beyond normal could mean excessive new leakage of air into the system. To reset the purge log, push the zero reset button next to the digital readout on the front panel.

### DIAGNOSTIC FEATURES

Although the APM is very reliable, after an extended operation or under severe conditions, problems may occur or be suspected. Under these conditions, due to the importance of the purging functions, restoration to normal operation is desired as quick as possible. The APM features diagnostic codes which are displayed on the digital readout when abnormal operation of the refrigeration system or the APM is detected. These flashing numbers help to identify the problem area. Below is a quick reference to these diagnostic codes. The digital readout will display the diagnostic code related to the occurrence which first put the APM into this mode; exception, 6666 will override 7777. Also see troubleshooting guide on page 10 for detailed explanation.

Flashing 2222 - LOSS OF "FOUL GAS" PRESSURE.

Flashing 3333 - PURGER TOO WARM.

Flashing 4444 - PURGED OVER 60 MINUTE TIME LIMIT.

Flashing 5555 - PURGER SHUT-OFF REMOTELY.

Flashing 6666 - LEVEL CONTROL OUT OF RANGE.

Flashing 7777 - LOSS OF HIGH PRESSURE LIQUID.

### PURGE POINT ENABLE SWITCHES

These switches are located on the control board and are all factory set to the ON position. They control whether or not a purge point can become active. If for example, only three purge points are being utilized, the number 4 purge point enable switch should be in the downward off position (see Figure 7). By doing this, the unused purge point is disabled and purger time is not wasted.

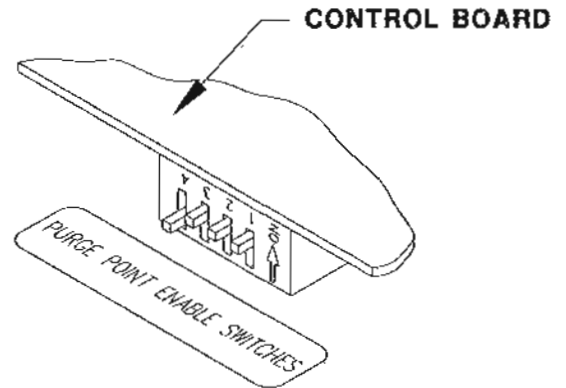

Figure 7.

### PUMP OUT PROCEDURE

Performing certain types of service on the APM may first require the purger to be pumped out (drained of liquid refrigerant). To begin pump-out, shut off foul gas line and high pressure liquid line. Wait for all refrigerant to evaporate to suction; this usually takes several hours to complete. Using safe refrigeration practices, reduce pressure to zero pounds. Check pressure gauge to make sure it reads zero psi. In addition to following these procedures, check lower portion of drainer and APM piping for signs of frost. If there's no frost, pump out is most probably complete. If there is frost, this means excess refrigerant is still in the drainer. To drain, energize drainer solenoid valve.

### SOLENOID VALVES

The APM is equipped with four solenoid valves. These are as follows: the liquid drainer solenoid valve (A); the liquid make-up solenoid valve (B); the purge gas solenoid valve (C); and the water solenoid valve (D). With the exception of the water solenoid valve, each is directly welded in-line and has a stainless steel removable seat/orifice (see Figure 8). The removable seat/orifice facilitates easy access to orifice for inspection or replacement. If necessary, the water solenoid valve (D), whose brass body has threaded ends, can easily be replaced or parts thereof changed.

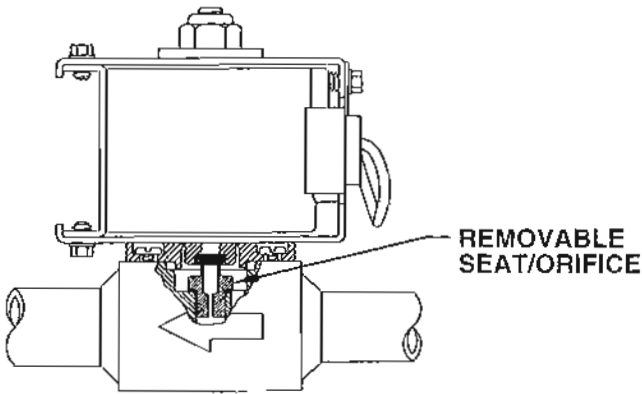

Figure 8.

In addition, separate remote point solenoid valves are required, one for each enabled purge point. These are not included with the APM. The Hansen type HS8 solenoid valve having 1/2" (13mm) port and stainless steel piston is recommended. Below is a typical purge point solenoid valve with close-coupled strainer (Figure 9).

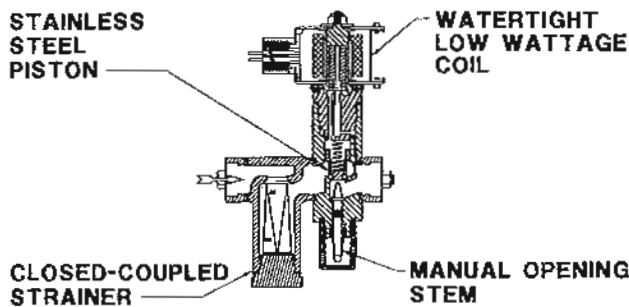

Figure 9.

### CHECK VALVES

There are three check valves on the purger. An 80 psig (5.5 bar) differential check valve is installed on the purge gas line to prevent any possibility of reverse flow of the water into the purger. A 225 psig (15.5 bar) differential relief check valve leads from the condensing coil inlet to the suction line; this prevents excessive purger pressure. A third check valve is installed from the liquid drainer to the evaporator coil to prevent reverse flow with a temporary loss of "foul gas" pressure.

### LIQUID DRAINER

The liquid drainer removes any condensed liquid that trickles from the "foul gas" line into the purger. This enables the purger to always be condensing gas rather than having liquid entering the condensing section of the purger and limiting proper operation. The drainer solenoid valve (A) will open to empty a reasonable amount of excess liquid directly to the flooded evaporator. However, if too much liquid comes down the "foul gas" line, due to improperly piped condensers, corrective action must be taken. See "Foul gas" piping section on page 3.

### STRAINER/ORIFICE

The strainer/orifice meters condensed liquid refrigerant from the high pressure side of the purger into its flooded evaporator. It features a dual filter arrangement to reduce potential orifice blockage. This dual filter (strainer) removes particles and houses the integral orifice (strainer/orifice screen assembly). See Figure 10.

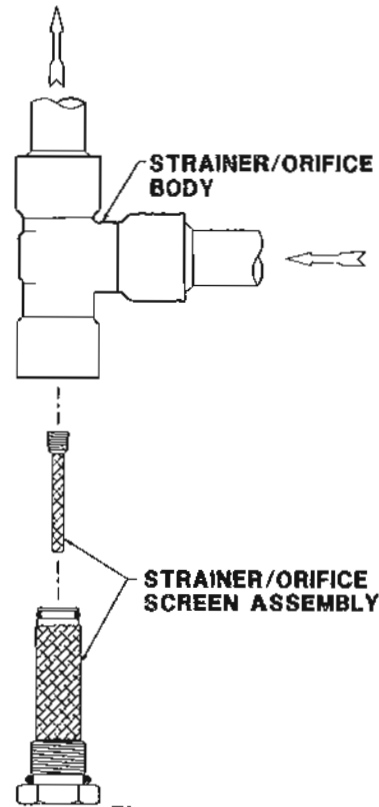

Figure 10.

### WATER BUBBLER

The APM is equipped with a water bubbler which eliminates any water bottle attention. Purge gas (non-condensibles) from the purger flows into the bottom of the water bubbler where residual ammonia can be absorbed into the water. The water with its absorbed ammonia flows to a drain. The water solenoid valve (D) opens to automatically replenish water to the bubbler each time the purge gas solenoid valve (C) energizes. A 30 second time delay keeps the water solenoid valve (D) open after the purge gas solenoid valve (C) de-energizes to refill water bubbler. Proper release of non-condensibles through bubbler is usually indicated by small 1/2" (13mm) diameter size bubbles.

## SECTION III APM OPERATION

The APM is designed to automatically start-up and operate without the assistance of plant personnel. Beginning at start-up, the following is a description of the refrigerant flow through a purger.

### PURGER START-UP SEQUENCE

On start-up, liquid refrigerant fills and begins to cool the purger. The liquid line solenoid valve (B) energizes to feed refrigerant to the flooded evaporator. The low side level sensor, located on the side of the flooded evaporator, senses when liquid reaches the proper level.

At the same time the flooded evaporator is filling, "foul gas" enters the flooded evaporator condensing coil and the refrigerant gas contained therein changes state to a liquid. The liquid and non-condensable gas gradually fill the downstream air separation chamber.

As the purger continues to cool down, a temperature sensor attached to the flooded evaporator senses its temperature. At approximately 40F (4.4°C) evaporator temperature, the readout will no longer display 3333 and the purger will enter the mode selected.

"Foul gas" is continually processed as long as a remote purge point solenoid is energized. It is important that one remote purge point solenoid valve is open at all times to prevent losing "foul gas" pressure to the purger. If "foul gas" pressure is lost (as sensed by pressure transducer), diagnostic code 2222 flashes on the APM digital readout. No purging of air will occur until pressure is restored.

### OPERATION

The "foul gas" may carry a certain amount of condensed refrigerant which is captured by the liquid drainer before it enters the flooded evaporator coil of the purger. The drainer level sensor operates solenoid valve (A) to drain the liquid directly into the low pressure flooded evaporator. This separation step enables the liquid refrigerant to bypass the purger's flooded evaporator condensing coil.

The liquid-free "foul gas" enters the condensing coil which is submerged in the cold liquid refrigerant of the flooded evaporator. The refrigerant gas condenses while the non-condensable gas passes into the air separator chamber. The condensed liquid refrigerant is removed from the air separator chamber through the strainer with integral orifice, and passed into the low pressure side of flooded evaporator.

Meanwhile, the non-condensable gas collects in the air separator chamber. The collected non-condensable gas gradually depresses the liquid level causing the high side level sensor to open both the purge gas solenoid valve (C) and water solenoid valve (D). Inside the water bubbler, non-condensable gas and water mix so that residual amounts of ammonia can be absorbed. The waste water is flushed to the drain through the overflow tube.

The purger will cycle each enabled remote purge point solenoid valve in sequence, when the purger is on Automatic Operation or New System Start-up. Purger will remain in selected purge point when in Manual Operation.

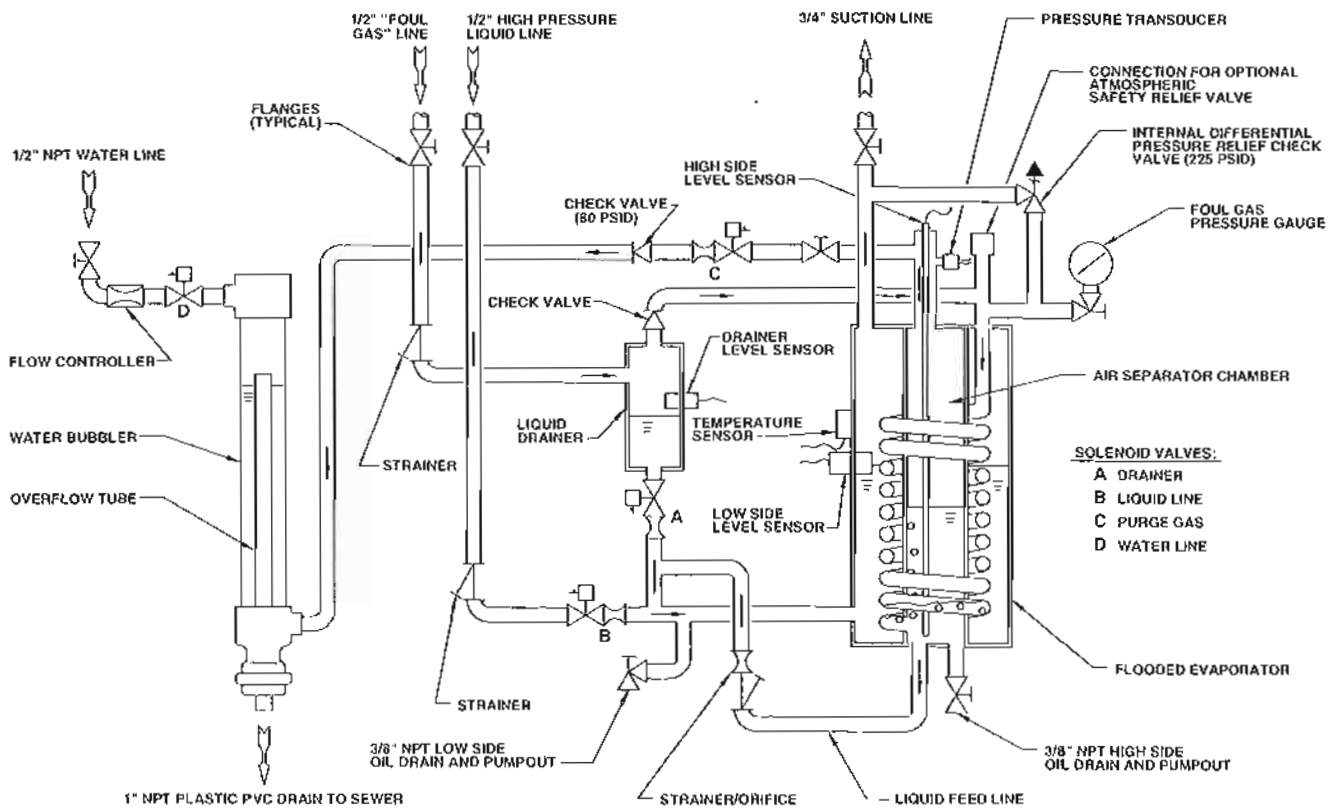

Figure 11.

## SECTION IV TROUBLE SHOOTING PURGER OPERATION

### Digital Readout Flashing 2222

**LOSS OF "FOUL GAS" PRESSURE.** This usually means the pressure in the air separator chamber is below 80 PSIG (5.5 bar). Pressure gauge on purger reads near suction pressure. The purger will not allow non-condensable gases to be released from the purger. However, the purger will continue to operate normally in all other functions.

**Reason 1:** Purge point solenoid coil burnt out.

**Check:** Push (to reset) remote purge point solenoid circuit breaker. Advance purge points with purge point advance button, waiting approximately 2 minutes before advancing, until circuit breaker opens or digital readout again flashes 2222. Faulty coil or wiring is now pinpointed.

**Action:** Replace coil or repair wire, and reset circuit breaker.

**Reason 2:** Remote purge point solenoid valve is jammed closed.

**Check:** The remote purge point solenoid valve which caused the diagnostic code to appear. Manually open solenoid valve and re-check pressure.

**Action:** If coil is energized, clean and replace solenoid valve parts as necessary. See also Caution section on page 12.

**Reason 3:** "Foul gas" line restricted.

**Check:** "Foul gas" line with closed shut-off valve(s) or plastic shipping cap in "foul gas" line flange.

**Action:** Open shut-off valves and/or remove shipping cap. See also Caution section on page 12.

**Reason 4:** Faulty pressure transducer.

**Check:** With the purger in an operational mode, check pressure gauge reading. If it is above 80 psig, check pressure transducer plug-in connector terminals 27 & 30 for 10 volts DC. Then check terminals 28 & 29 for at least 13 mV.

**Action:** If terminals 27 & 30 do not have 10 volts DC check for faulty wiring. If terminals 28 & 29 do not have at least 13 mV, replace pressure transducer (p/n 20-1857) with purger at zero pressure. See also Caution section on page 12.

### Digital Readout Flashing 3333

**PURGER TOO WARM.** If the purger evaporator temperature is 40F (4.4°C) or warmer, the purger will not release non-condensable gas from the purger because excessive refrigerant would also escape. The purger will continue to operate normally in all other functions. This code is also displayed during Initial start-up until purger flooded evaporator is cooled down.

**Reason 1:** Suction temperature too high.

**Check:** Pressure at purger suction line connection.

**Action:** Connect to lower temperature suction.

**Reason 2:** Restriction in suction line.

**Check:** Suction line and shut-off valves. These should be a minimum of 3/4" in size. On new installations, also check for plastic shipping cap in suction line flange.

**Action:** Eliminate restriction. See also Caution section on page 12.

**Reason 3:** Flooded evaporator inside of purger not filled with refrigerant.

**Check:** Liquid line shut-off valve. Also, check for energized liquid line solenoid valve (B).

**Action:** Open liquid line shut-off valve. If not energized, check for voltage at liquid line solenoid valve coil. Replace coil if burnt-out.

**Reason 4:** Faulty temperature sensor.

**Check:** With temperature sensor plug-in connector disconnected from power board (see Figure 4), check electrical resistance of sensor across wire leads.

**Action:** If resistance not between 30 K ohms and 486 K ohms replace temperature sensor (p/n 67-0052) with purger at zero pressure. See also Caution section on page 12.

### Digital Readout Flashing 4444

**PURGED OVER 60 MINUTE TIME LIMIT.**

If non-condensibles are released from the purger for 60 minutes continuously, a time delay will close the purge gas solenoid valve (C). This limits the possibility of substantial refrigerant inadvertently being released into the water bubbler in the unlikely event of purger malfunction.

**Reason 1:** Continuously large volume of non-condensibles being removed from system.

**Action:** Reset the time delay by momentarily turning the APM to Purger Switched Off and back to the desired operation mode. Delay is now reset for up to another hour of continuous purging. Otherwise put purger in New System Start-up mode for continuous purging without 60 minute time limit.

**Reason 2:** Purge gas solenoid valve (C) is not opening or removable seat/orifice blocked.

**Check:** For energized purge gas solenoid valve (C). If not, check for voltage at solenoid coil.

**Action:** Replace coil if burnt-out, otherwise clean or replace removable seat/orifice inside solenoid valve body. See also Caution section on page 12.

**Reason 3:** Shut-off valve located before purge gas solenoid valve (C) is closed.

**Check:** Purge gas not being sent to bubbler.

**Action:** Open valve.

### Digital Readout Flashing 5555

**PURGER SHUT-OFF REMOTELY.** This code indicates that the optional interlock remote relay contacts are open. These contacts are connected to the purger via the power/interlock plug-in connector terminals 11 and 12.

**Reason 1:** Purger is temporarily shut-off due to the interlocked compressor (or other device) being shut down by temperature controls or safety devices.

**Check:** Wait until interlocked compressor (or other device) begins to operate. If digital readout does not stop flashing diagnostic code 5555, then check interlock relay for proper operation.

#### **Digital Readout Flashing 6666**

**LEVEL CONTROL OUT OF RANGE.** This Flashing 6666 code will alternate with either a 6661, 6662, or 6663 code. The second code indicates which level sensor is out of the normal sensing range. This may indicate a mechanical or electrical problem with the drainer level sensor (6661), the low side level sensor (6662), or the high side level sensor (6663).

**Reason 1:** Discontinuity of coaxial wire from probe to control board.

**Check:** Level sensor coaxial connectors at control board for tightness.

**Action:** If connection appears proper, replace the suspected level sensor, with purger isolated from system and pressure at zero. See also Caution section on page 12.

#### **Digital Readout Flashing 7777**

**LOSS OF HIGH PRESSURE LIQUID.** If the liquid make-up solenoid valve remains energized for more than 30 minutes, it indicates insufficient high pressure liquid available to maintain an adequate level in the flooded evaporator of the purger. The purger will not purge air until this is corrected.

**Reason 1:** Liquid line solenoid valve (B) is not opening or removable seat/orifice blocked.

**Check:** For energized liquid line solenoid valve (B). If not, check for voltage at solenoid coil.

**Action:** Replace coil if burnt-out, otherwise clean or replace removable seat/orifice inside solenoid valve body. See also Caution section on page 12.

**Reason 2:** Liquid line restricted.

**Check:** Liquid line for closed shut-off valves, plugged strainers, or plastic shipping cap in liquid line flange.

**Action:** Inspect piping for possible closed shut-off valve. Open shut-off valves, clean strainer, or remove shipping cap. See also Caution section on page 12.

**Reason 3:** Flooded evaporator is full of oil.

**Check:** For oil at drain valves.

**Action:** Drain oil according to safe refrigeration practices.

#### **Non-condensibles are not being released.**

*(See also page 10; Digital Readout Flashing 3333)*

**Reason 1:** Non-condensibles not present in system.

**Check:** Compare refrigerant liquid temperature from condenser exit with condensing pressure. The pressure/temperature relationship should be within 2 or 3 PSIG (0.14 to 0.21 bar).

**Action:** None at this time.

**Reason 2:** Strainer/orifice plugged.

**Symptom:** Purger appears to be operating properly. Liquid feed line not frosted.

**Check:** Strainer/orifice for restriction.

**Reason 3:** "Foul gas" line is flooded with liquid.

**Symptom:** Line from bottom of liquid drainer solenoid valve (A) to inlet of purger evaporator often remains frosted.

**Check:** Condenser and "foul gas" piping. In many cases, the problem is liquid refrigerant being drawn from purge point. To prevent this from happening, select purge point locations above liquid surfaces and make sure purge point lines are installed so that only vapor, and not liquid, can be drawn in. Refer to Piping Instructions in Section I of this bulletin.

**Action:** Correct condenser and "foul gas" piping.

#### **Ammonia instead of non-condensibles released from purger.**

*(See also page 10; Digital Readout Flashing 3333)*

**Reason 1:** Purge gas solenoid valve (C) leaking at seat.

**Symptom:** Slow leak of non-condensibles to bubbler when Purging status light is off.

**Check:** Purge gas solenoid valve (C) has dirt or worn seat.

**Action:** Remove, clean or replace seat/orifice and solenoid tube plunger. See also Caution section on page 12.

**Reason 2:** Oil in purger.

**Symptom:** No frost around low side oil drain valve.

**Action:** Remove oil through both the low side and high side drain valves (See Figure 1) per safe refrigeration procedures and suggested oil removal instructions describe in the Oil Drain section on page 4.

#### **Water bubbler develops excessive mineral coating.**

**Reason 1:** Hard water.

**Action:** Add vinegar to bubbler water. Clean with supplied brush. Use water conditioning housing and cartridge in water supply line to purger.

### **DEFINITIONS**

**Non-condensibles:** Mostly air, this gas causes higher than necessary head pressure. Typically air enters a refrigeration system through vacuum leaks, break down of oil and refrigerant, and during service repairs.

**"Foul gas":** Mixture of non-condensibles and refrigerant gas.

**P-trap:** Piping arrangement, typically in condenser drain lines, to prevent passage of gas while enabling liquid to proceed.

**High pressure liquid:** Refrigerant liquid source from condenser or receiver.

**Purge gas:** The non-condensibles result of the separation of refrigerant gas from the "foul gas" by the purger.

**Purge point:** Represents a location on the refrigeration system from which "foul gas" is removed.

**Enabled purge points:** Purge points connected to purger and selected by the purge point enable switches, see page 7.

**Active purge point:** Purge point from which purger is currently removing "foul gas".

**Remote purge point solenoid valve:** A solenoid valve controlled by the purger located at a purge point.

**Water bubbler:** System by which the purge gas is cleaned of residual ammonia.

## OPTIONAL VALVE PACKAGE (VPM)

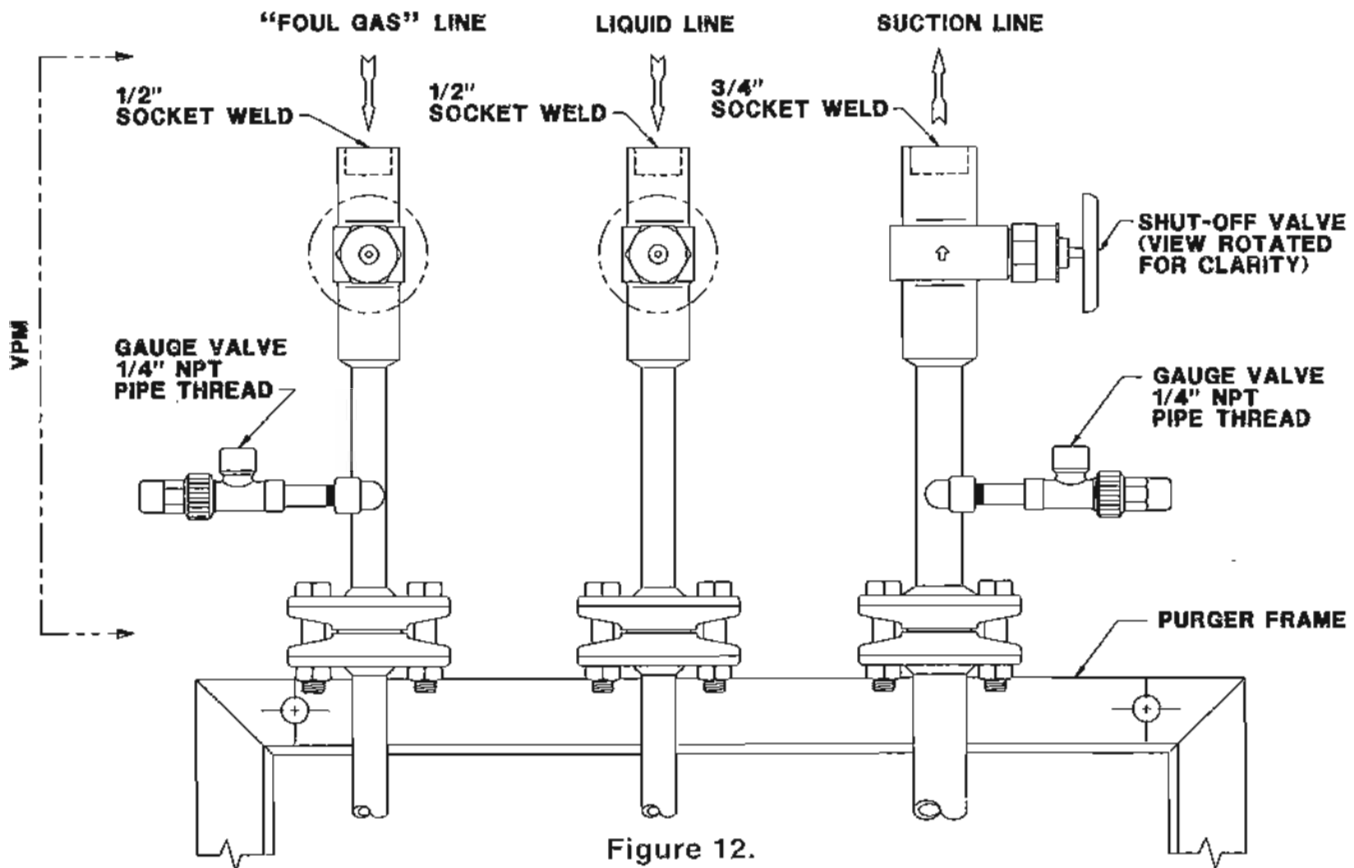

### PARTS LIST

#### ELECTRICAL

Control board .....	20-1836
Power board .....	20-1845
Cable, control board .....	20-1837
Pressure transducer .....	20-1857
Temperature sensor .....	67-0052
High side level sensor .....	77-0534
Drainer and low side level sensor .....	77-0535
Solenoid coil kit, 230V with DIN plug .....	70-1055
Solenoid coil kit, 115V with DIN plug .....	70-1054

#### MECHANICAL

Solenoid tube/plunger kit .....	70-1059
Water solenoid valve (D), less coil .....	HS2B(10)
APM bubbler .....	20-1959
Strainer/orifice screen assembly kit includes strainer/orifice screen assembly and necessary o-rings .....	20-2177
Water flow controller .....	20-1985
Removable seat/orifice kits	
For solenoid valve (B) or (C) .....	70-1068
For solenoid valve (A) .....	70-1069
80 psid check valve .....	20-1949
Foul gas/liquid line strainer kits include strainer basket and o-ring .....	78-1010

### CAUTION

Hansen purgers are only for refrigeration systems. These instructions and related safety precautions must be read completely and understood before selecting, using, or servicing these purgers. Only knowledgeable, trained refrigeration mechanics should install, operate, or service these purgers. Stated temperature and pressure limits should not be exceeded. Purger components should not be removed from purger unless system has been evacuated to zero pressure. See also Safety Precautions in current List Price Bulletin and Safety Precautions Sheet supplied with product. Escaping refrigerant can damage the eyes, lungs or other bodily parts.

### WARRANTY

Hansen electrical and electronic parts are guaranteed against defective materials and workmanship for 90 days F.O.B. our plant. All other components are guaranteed for one year F.O.B. our plant. No consequential damages or field labor is included.

## HANSEN TECHNOLOGIES CORPORATION

6827 High Grove Boulevard  
Burr Ridge, Illinois 60521 U.S.A.  
Telephone: (630) 325-1565  
Toll-free: 1-800-426-7368  
FAX: (630) 325-1572