

HANSEN TECHNOLOGIES CORPORATION



HCK4-4 Check Valve

INTRODUCTION

The HCK4 series of dependable, compact, rugged in-line check valves (disc type non-return valves) is ideally suited for refrigerant flow control applications. Valves open wide for flow in the arrow direction on the valve body. Valves close quickly and reliably when flow reversals occur.

Plated bodies and stainless steel seat discs and springs enable them to withstand expected industrial refrigeration conditions. Furthermore, these check valves can be mounted in any position, close-coupled to other valves, and use same flanges as Parker R/S, Frick, and Henry.

ADVANTAGES

These compact check valves offer reliable operation regardless of position. Corrosion resistant stainless steel seat disc. Metal-to-metal seats facilitate durable, tight closing of valves.

APPLICATIONS

These in-line check valves are designed to provide refrigerant flow control to hot gas lines, liquid lines, compressor discharge lines, suction lines, and hot gas heated drain pans.

These valves are not recommended for use with pulsating loads such as low speed compressor discharge and screw compressor side port applications. For applications such as these, use Hansen HCK1 piston type check valves.

Specifications, Applications, Service Instructions & Parts

HCK4 IN-LINE CHECK VALVES 5/8" thru 4" PORT (16 thru 100 mm)

Flanged
3/8" thru 4"
FPT, SW, WN, ODS
for refrigerants

KEY FEATURES

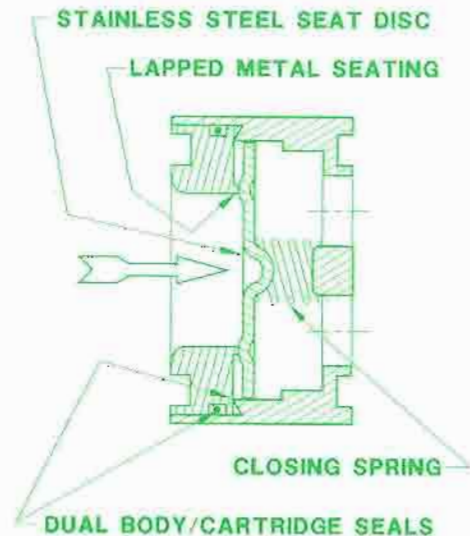

ADDITIONAL FEATURES

- Mounts in any position
- Less than 1 PSID wide opening pressure
- Can be close-coupled
- Low bubble leakage tolerance
- For Ammonia, R22, R134a, and other approved refrigerants
- Dimensionally replaces R/S CK4A-2, -3, -4, -8, & -1
- U.L. Listed

MATERIAL SPECIFICATIONS

Body:

5/8" thru 1 1/4": Steel, ASTM A108, zinc chromate plated

1 1/2" thru 4": Ductile iron, ASTM A536 (nodular iron GGG-40), zinc chromate plated

Seat Disc: Stainless steel

Seat Cartridge:

5/8" thru 1 1/4": Stainless steel, ASTM A582

1 1/2" thru 4": Steel, ASTM A108, zinc chromate plated

Spring: Stainless steel

Safe Working Pressure: 400 PSIG (27 bar)

Operating Temperature: -60F to 240F (-50 to 115°C)

INSTALLATION

Valve may be located in any position. Arrow on valve body should match direction of flow. Secure valve with gaskets between flanges and tighten bolts evenly. Do not use this valve or any component to align pipes or tighten gap between flanges.

Do not install on inlet side of solenoid valves or control valves with electric shut-off or shut-off valves unless a relief valve is used from therein between piping. Do not install on inlet side of outlet pressure regulators where liquid may become trapped. Instead, check valves should be located on outlet side of these valves. Check valves can be close-coupled to other matching solenoid valves, pressure regulators, or strainers by using a Male Adapter Ring and longer bolts supplied when so specified on order.

INSTALLATION DIMENSIONS

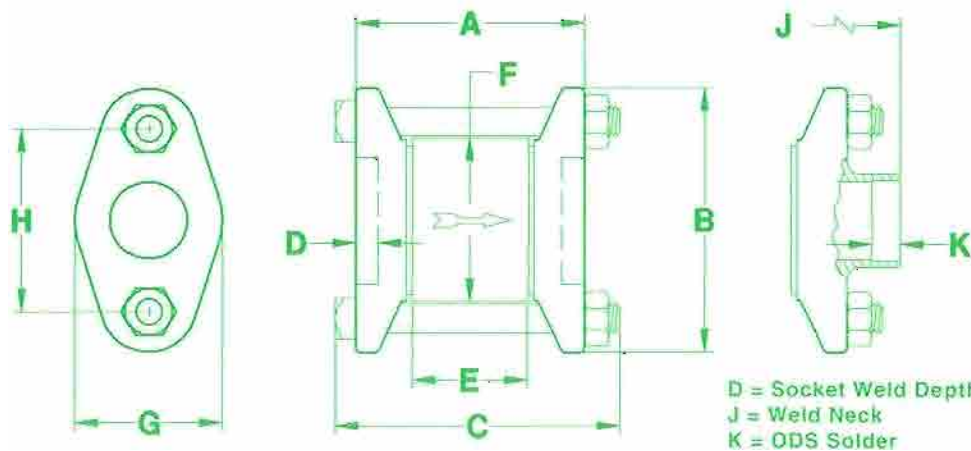

DIMENSION LETTER	HCK4-2* 5/8" PORT	HCK4-3* 3/4" PORT	HCK4-4* 1" PORT	HCK4-5 1 1/4" PORT	HCK4-7 1 1/2" PORT	HCK4-8* 2" PORT	HCK4-9 2 1/2" PORT	HCK4-0 3" PORT	HCK4-1* 4" PORT
A	2.50" (64 mm)	3.25" (83 mm)	3.25" (83 mm)	3.25" (83 mm)	5.06" (129 mm)	5.06" (129 mm)	6.06" (154 mm)	6.06" (154 mm)	6.39" (162 mm)
B	3.19" (81 mm)	4.50" (114 mm)	4.50" (114 mm)	4.50" (114 mm)	4.56" (116 mm)	4.56" (116 mm)	6.00" (152 mm)	6.00" (152 mm)	7.13" (181 mm)
C	3.50" (89 mm)	4.50" (114 mm)	4.50" (114 mm)	4.50" (114 mm)	6.38" (162 mm)	6.38" (162 mm)	7.50" (191 mm)	7.50" (191 mm)	8.00" (203 mm)
D	0.38" (10 mm)	0.50" (13 mm)	0.50" (13 mm)	0.50" (13 mm)	0.75" (19 mm)	0.75" (19 mm)	1.00" (25 mm)	1.00" (25 mm)	1.00" (25 mm)
E †	1.03" (26 mm)	1.22" (31 mm)	1.22" (31 mm)	1.22" (31 mm)	2.56" (65 mm)	2.56" (65 mm)	2.92" (74 mm)	2.92" (74 mm)	3.50" (89 mm)
F	1.50" (38 mm)	2.37" (60 mm)	2.37" (60 mm)	2.37" (60 mm)	3.62" (92 mm)	3.62" (92 mm)	4.84" (123 mm)	4.84" (123 mm)	6.06" (154 mm)
G	1.56" (40 mm)	2.50" (64 mm)	2.50" (64 mm)	2.50" (64 mm)	4.56" (116 mm)	4.56" (116 mm)	6.00" (152 mm)	6.00" (152 mm)	7.13" (181 mm)
H	2.19" (56 mm)	3.12" (79 mm)	3.12" (79 mm)	3.12" (79 mm)	3.06" (78 mm)	3.06" (78 mm)	4.00" (102 mm)	4.12" (105 mm)	5.00" (127 mm)
J	3.26" (83 mm)	4" (102 mm)	4" (102 mm)	4" (102 mm)	6.06" (154 mm)	6.06" (154 mm)	7.06" (179 mm)	7.06" (179 mm)	9.89" (251 mm)
K	0.33" (8 mm)	0.49" (12 mm)	0.59" (15 mm)	0.62" (16 mm)	0.71" (18 mm)	0.87" (22 mm)	0.96" (24 mm)	1.08" (27 mm)	1.40" (36 mm)
Valve Cv (Kv)	5.8 (5)	8.2 (7)	11.7 (10)	14.0 (12)	39 (33)	50 (43)	74 (63)	93 (80)	210 (180)
Pipe Size	1/2", 3/4"	3/4"	1"	1 1/4"	1 1/2"	2"	2 1/2"	3"	4"

*Dimensionally replaces R/S check valve models CK4A-2, -3, -4, -8, and -1. † "E" dimension is check valve body outside edge to outside edge. Flange groove depth: nominal 0.12" each of two; gasket thickness: nominal 0.06" each of two.

PARTS LIST

HCK4-2 (2-BOLT)

ITEM	DESCRIPTION	QTY	PART NO
	Valve Assembly Kit Above Kit Consists of:		
1	Seat Disc	1	72-0069
2	Closing Spring	1	72-0070
3	Seat Cartridge	1	72-0068
4	Seat Cartridge O-ring	1	72-0071
5	Flange Gasket	2	70-0065
6	Body, HCK4-2	1	72-0067
7	Bolt ($\frac{7}{16}$ " - 14 x 3.25")	2	70-0225
8	Nut ($\frac{7}{16}$ " - 14)	2	70-0055
9	Flange (FPT, SW, WN, ODS)	2	FACTORY

HCK4-2 (2-BOLT)

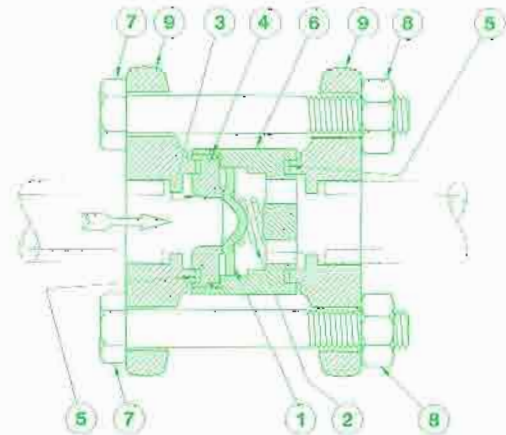

Socket weld shown. FPT, weld neck, ODS: available.

HCK4-3, -4, -5 (2-BOLT)

ITEM	DESCRIPTION	QTY	PART NO
	Valve Assembly Kit Above Kit Consists of:		
1	Seat Disc	1	72-0006
2	Closing Spring	1	70-0204
3	Seat Cartridge	1	72-0002
4	Seat Cartridge O-ring	1	72-0003
5	Flange Gasket	2	70-0132
6a	Body, HCK4-3	1	72-0004
6b	Body, HCK4-4	1	72-0008
6c	Body, HCK4-5	1	72-0001
7	Bolt ($\frac{5}{8}$ " - 11 x 4")	2	72-0005
8	Nut ($\frac{5}{8}$ " - 11)	2	70-0136
9	Flange (FPT, SW, WN, ODS)	2	FACTORY

HCK4-3, -4, -5 (2-BOLT)

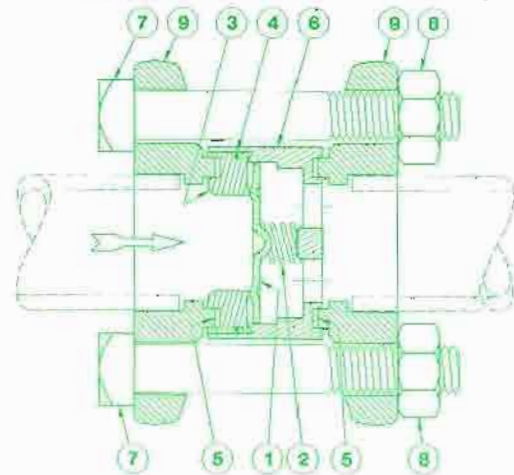

Socket weld shown. FPT, weld neck, ODS: available.

HCK4-7, -8, -9, -0, -1 (4-BOLT)

ITEM	DESCRIPTION	QTY	PART NO
1a	Seat Disc 1½", 2"	1	72-0016
1b	Seat Disc 2½", 3"	1	72-0034
1c	Seat Disc 4"	1	72-0053
2a	Closing Spring 1½", 2"	1	72-0021
2b	Closing Spring 2½", 3"	1	72-0032
2c	Closing Spring 4"	1	72-0048
3a	Seat Cartridge 1½", 2"	1	72-0020
3b	Seat Cartridge 2½"	1	72-0029
3c	Seat Cartridge 3"	1	72-0028
3d	Seat Cartridge 4"	1	72-0047
4a	Seat Cartridge O-ring 1½", 2"	1	72-0017
4b	Seat Cartridge O-ring 2½", 3"	1	72-0027
4c	Seat Cartridge O-ring 4"	1	72-0049
5a	Flange Gasket 1½", 2"	2	75-0138
5b	Flange Gasket 2½"	2	75-0125
5c	Flange Gasket 3"	2	75-0137
5d	Flange Gasket 4"	2	75-0253
6a	Body, HCK4-7	1	72-0042
6b	Body, HCK4-8	1	72-0019
6c	Body, HCK4-9	1	72-0025
6d	Body, HCK4-0	1	72-0026
6e	Body, HCK4-1	1	72-0046
7a	Bolt, HCK4-7, -8 ($\frac{5}{8}$ " - 11 x 6")	4	70-0268
7b	Bolt, HCK4-9, -0 ($\frac{3}{4}$ " - 10 x 7")	4	72-0033
7c	Bolt, HCK4-1 ($\frac{7}{8}$ " - 9 x 7.5")	4	72-0051
8a	Nut, HCK4-7, -8 ($\frac{5}{8}$ " - 11)	4	70-0136
8b	Nut, HCK4-9, -0 ($\frac{3}{4}$ " - 10)	4	75-0210
8c	Nut, HCK4-1 ($\frac{7}{8}$ " - 9)	4	75-0280
9	Flange (FPT, SW, WN, ODS)	2	FACTORY

HCK4-7, -8, -9, -0, -1 (4-BOLT)

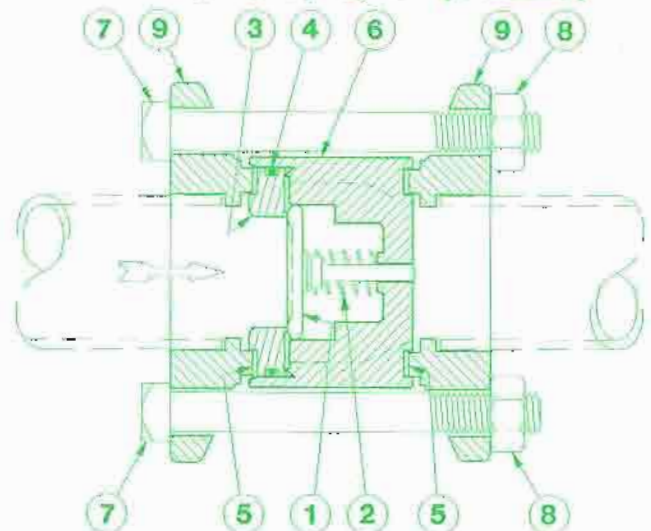

Socket weld shown. Weld neck, ODS: available.

OPERATION

HCK4 check valves are normally closed valves. As inlet pressure increases, it overcomes the closing spring force. As the seat disc is pushed back and away from the seat cartridge, flow through the valve occurs. The valve will remain open until the inlet pressure drops below the closing spring force or there is a flow reversal, at which time the seat disc will close against the seat cartridge, preventing reverse flow.

SIZING

Check valves are normally selected on the basis of line size. However, for gas flow applications at low load conditions, a minimum of 1 psid across the valve is essential. This will maintain valve at full open position. Valve Cv (Kv) is listed in the installation dimension table on page 2. Factory valve sizing assistance is available.

SERVICE AND MAINTENANCE

These valves are a reliable part of a refrigeration system. However, if valve does not appear to be operating satisfactorily, isolate it from the refrigeration system. Remove all refrigerant from associated piping and valves. Follow the guidelines in the caution section. Loosen each flange nut on the check valve. Break each flange gasket seal. Carefully loosen flange bolts one at a time, being cautious to avoid any refrigerant which still may be present. Remove check valve from flanges and inspect. Lapped seating surfaces should be smooth and free of pits or scratches.

To confirm valve operation, move seat disc with eraser end of pencil. Movement should be free from friction. If not, disassemble and visually inspect for dirt in valve or burrs on seat disc. Clean or replace parts as necessary. Valve discs and seats can be restored by lapping on a flat plate.

Reassemble valve and insert between flanges. Replace and tighten bolts and nuts evenly. Carefully check for leaks before returning to service.

CAUTION

Hansen check valves are only for refrigeration systems. These instructions and related safety precautions must be completely read and understood before selecting, using, or servicing these valves. Only knowledgeable, trained refrigeration mechanics should install, operate, or service these valves. Stated temperature and pressure limits should not be exceeded. Valves should not be removed unless system has been evacuated to zero pressure. See also Safety Precautions in current List Price Bulletin and Safety Precautions Sheet supplied with product. Escaping refrigerant might cause personal injury, particularly to the eyes and lungs.

WARRANTY

Hansen valves are guaranteed against defective materials or workmanship for one year F.O.B. our plant. No consequential damages or field labor is included.

ORDERING INFORMATION, HCK4 CHECK VALVES

TYPE	PORT SIZE (mm)	FLANGE CONNECTION STYLE & SIZES		
		FPT, SW, WN		ODS
		STD	ALSO	STD
HCK4-2*	3/8" (16)	1/2"	3/8", 3/4"	3/8"
HCK4-3*	1/2" (20)	3/4"	1", 1 1/8"	7/8"
HCK4-4*	1" (25)	1"	3/4", 1 1/8"	1 1/8"
HCK4-5	1 1/8" (32)	1 1/8"	3/4", 1"	1 1/8"
HCK4-7	1 1/2" (40)	1 1/2"	2"	1 1/2"
HCK4-8*	2" (50)	2"	1 1/2"	2 1/8"
HCK4-9	2 1/2" (65)	2 1/2"	3"	2 5/8"
HCK4-0	3" (80)	3"	--	3 1/8"
HCK4-1*	4" (100)	4"	--	4 1/8"

* Replaces R/S CK4A-2, CK4A-3, CK4A-4, CK4A-8, & CK4A-1. HCK4-2 close-couples to HS6 & HS8 Solenoid Valves. HCK4-3, -4, & -5 close-couples to HS7 Solenoid Valve. FPT available only 3/8" to 1 1/2".

TO ORDER: Specify valve type, connection style and size, and close-coupling information if needed.

TYPICAL SPECIFICATIONS

"Refrigeration in-line check valves shall have steel or ductile iron bodies, stainless steel seat discs, stainless steel closing springs, and be suitable for a safe working pressure of 400 PSIG, as manufactured by Hansen Technologies Corporation type HCK4 or approved equal."

Typical close-coupling to solenoid valve.

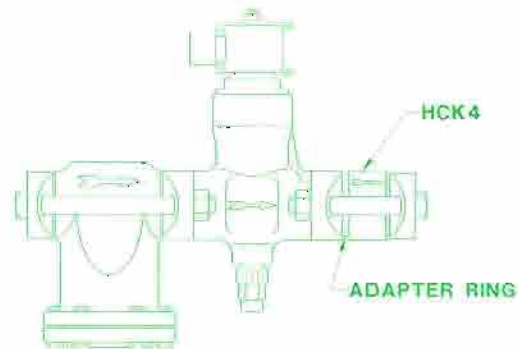

HANSEN TECHNOLOGIES CORPORATION

6827 High Grove Boulevard
Burr Ridge, Illinois 60521 U.S.A.
Telephone: (630) 325-1565
Toll-free: 1-800-426-7368
FAX: (630) 325-1572