

HANSEN TECHNOLOGIES CORPORATION



SHP
SVP
Level Transducer Probes

INTRODUCTION

Due to the increasing cost of refrigerants and the existing and pending governmental regulations concerning the escape, leakage and replenishment of refrigerants, more accurate and sophisticated methods are needed to conserve and track refrigerant usage. These level transducer probes are specifically designed to be inserted directly into refrigerant receivers and facilitate the continuous accurate measurement of refrigerant liquid levels. From this, the following results can be achieved: refrigerant loss detection, refrigerant inventory measurements, warnings of excessive refrigerant levels, insufficient refrigerant quantity and other information available as a result of receiver liquid level monitoring. Furthermore, it can become a very valuable trouble shooting tool, aiding in the speedy return to normal refrigeration system operation.

KEY FEATURES

- Solid state - No moving parts
- Full length vertical monitoring
- Proven design; no optics
- 0 to 5 volt D.C. signal output *
- Standard 3/4" NPT fitting
- Custom lengths available
- Watertight NEMA 4 (IP65) enclosure
- Suitable for R22, R134a, and other approved refrigerants

Specifications, Applications, Service Instructions & Parts

S SERIES REFRIGERANT LEVEL TRANSDUCER PROBES

0 to 5 Volt D.C. Output *
for vertical or horizontal
receivers

TYPICAL APPLICATIONS

VERTICAL RECEIVER

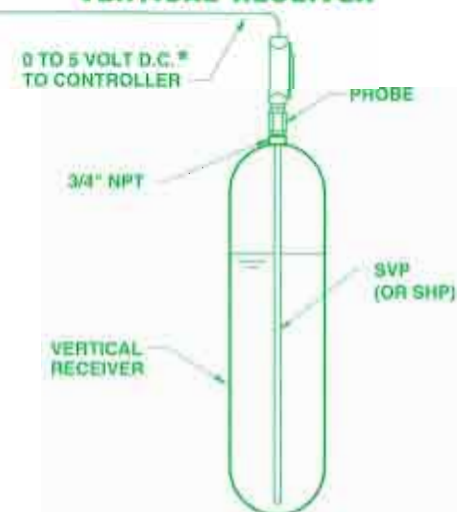

HORIZONTAL RECEIVER

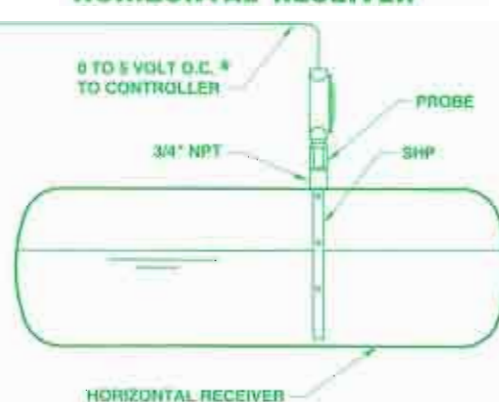

* Or 1 to 6 volt D.C. Output

MATERIAL SPECIFICATIONS

ELECTRICAL

Signal Output: 0 to 5 volt D.C. (or 1 to 6 volt) proportional to liquid level
Maximum Load: 10K ohms
Supply Voltage: 11 to 47 volt D.C.
Ambient Temperature Range: 50F to 125F
Enclosure: NEMA 4, watertight (IP65)
Linearity: Typically $\pm 2\%$ of actual

MECHANICAL

Safe Working Pressure: 400 PSIG (27 bar)
Refrigerant Temperature: 50F to 150F (10 to 65°C)
heavy-duty construction for other temperatures
Probe: Stainless steel, teflon enclosed
Shielding Tube: Stainless steel (SHP models only)
Fitting: Steel, zinc chromate plated
Threads: $\frac{3}{4}$ " NPT

APPLICATION

Horizontal Receivers: 6" to 24" diameter
Vertical Receivers: 12" to 20" diameter
(other diameters need special engineering)

ADVANTAGES

These level transducer probes are normally supplied factory pre-calibrated and tested. There are no moving parts to break, jam or fail. Probe-to-receiver connection is simple $\frac{3}{4}$ " NPT. Probes provide a 0 to 5 volt D.C. output (or 1 to 6 volt) proportional to liquid level. This signal is already commonly used with supermarket refrigeration rack system controllers, PLC's, and other accessories for various purposes. The signal output is conditioned to ignore normal turbulence inside receiver to provide a steady, accurate indication of level.

These probes enable user to easily and precisely set up: high level alarm/cutout, low level alarm/cutout, level monitoring and refrigerant inventory calculation. If signal is input to a PLC or rack system controller with modem capabilities, it can be accessed remotely by a central office, local contractor, or electronics manufacturer for trouble shooting, refrigerant inventory control or other purposes.

Heavy-duty construction is available for non-standard applications where the ambient or refrigerant temperature range is exceeded, probe insertion into cold evaporators or accumulators, or for outdoor use. This version includes an extended probe body neck, special electronic temperature compensation, and epoxy resin encapsulated electronics for extra moisture protection.

INSTALLATION

To select proper probe size, receiver inside height and fitting length should be known, see diagram below. Subtract 1.06" or 27 mm (typical engagement plus probe minimum clearance to receiver bottom) from "F" dimension; the result is the maximum possible insertion length of probe. Actual probe insertion length may be less, perhaps down to the next standard insertion length, provided it is long enough to measure lowest desired receiver level. Minimum clearance is suggested to avoid possible damage to probe by running it into bottom of receiver.

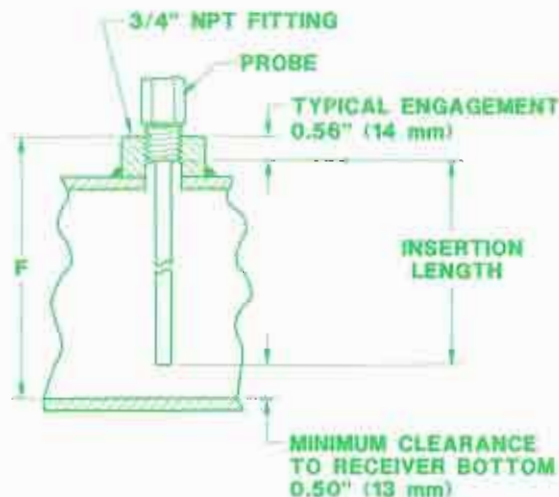

Locate fitting away from liquid inlet of receiver to avoid splashing probe with incoming refrigerant. Also, avoid possible probe interference with dip tube or other internal parts. Adequate clearance above the $\frac{3}{4}$ " FPT fitting on the receiver should be provided to permit the installation and removal of probe without bending.

Carefully remove probe from carton. Use proper sealant on probe-to-receiver connection (for SVP electrical contact is required via the NPT threaded fitting; excessive teflon tape might cause trouble). Insert into the NPT opening on the receiver. Tighten probe on hex; do not grip probe housing. Pressurize receiver and test for leaks.

ELECTRICAL

These level transducer probes are low voltage, three wire devices. They require an input power supply of 11 to 47 volt D.C. and will provide a regulated signal output of 0 to 5 volt D.C. proportional to liquid level, but can be calibrated for 1 to 6 volt D.C. output. Control loop wiring size should be at least 20 AWG (0.5 mm²) and limited to 100 ft. (30 m) in length. For best electrical noise protection, do not run control loop wiring with or near power wiring. See page 3 for typical wiring diagram.

Important: To protect electronics from moisture, dirt, etc., seal the $\frac{3}{4}$ " NPT electrical opening on top of probe housing with a watertight cable connector or seal wires inside field installed conduit fitting with silicone sealant.

INSTALLATION DIMENSIONS

| FOR HORIZONTAL RECEIVERS * | |
|----------------------------|------------------|
| CAT. NO. | INSERTION LENGTH |
| SHP00 | 0" (152 mm) |
| SHP08 | 8" (203 mm) |
| SHP12 | 12" (305 mm) |
| SHP18 | 18.3" (387 mm) |
| SHP20 | 19.2" (487 mm) |
| SHP24 | 23.1" (586 mm) |

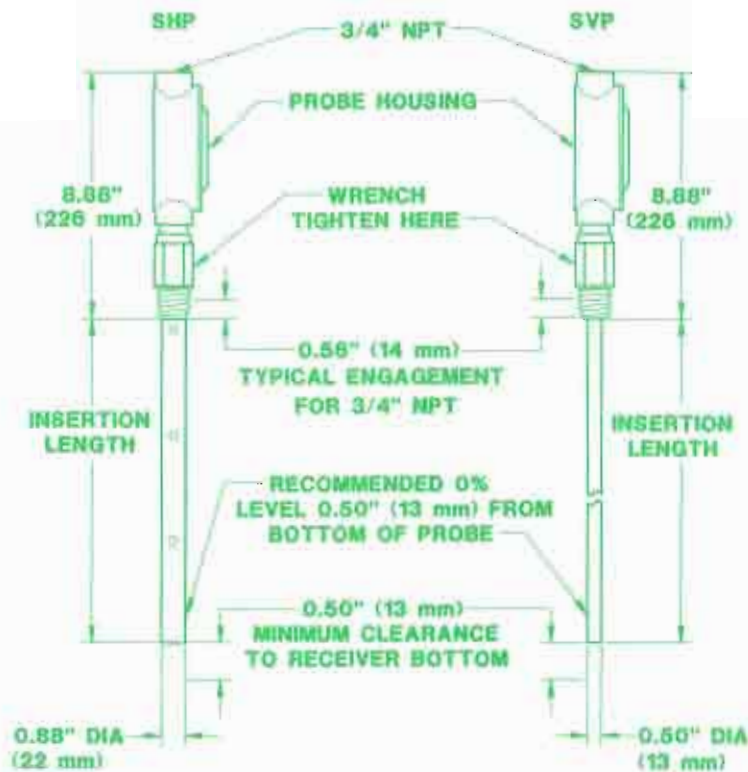

| FOR VERTICAL RECEIVERS * | |
|--------------------------|------------------|
| CAT. NO. | INSERTION LENGTH |
| SVP36 | 36" (914 mm) |
| SVP48 | 48" (1219 mm) |
| SVP54 | 64" (1372 mm) |
| SVP60 | 80" (1824 mm) |

* Horizontal Receiver Probes (SHP) should also be used in short, narrow or wide vertical receivers.

TYPICAL WIRING DIAGRAM

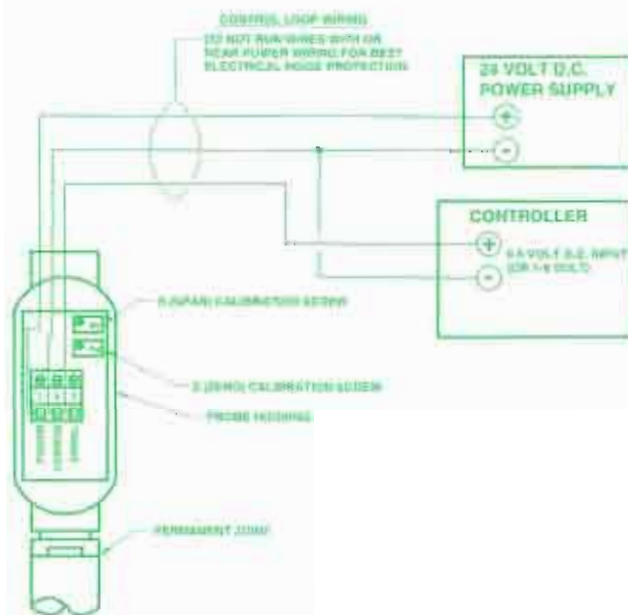

RE-CALIBRATION INSTRUCTIONS

These transducer probes are accurately factory pre-calibrated for receivers with the specified refrigerant. SHP probes should not require any field adjustment in calibration settings whatsoever unless refrigerant is different. SVP probes are factory calibrated for a 18" diameter vertical receiver and generally will only require re-calibration for other receiver diameters or refrigerants. If one determines that a transducer probe is not satisfactorily calibrated or that refrigerant is other than that specified on probe housing, re-calibrate as described below.

These instructions assume a 0 to 5 volt calibration; 1 to 6 volt procedure is the same except values are different. To check voltage output, a volt meter should be installed in parallel with the signal (terminal #3) and common (terminal #2) leads of the control loop.

Lower the refrigerant level in the receiver to a level equal to 0%; the volt meter should display 0.05 volts D.C. If not adjust the Z (zero) calibration screw. Probe electronics will not adjust to zero (0.00) volts.

Raise the liquid level in the receiver to the 50% level or some other known level. The volt meter should display 2.5 volts D.C. for a 50% probe immersion level. For other levels, the corresponding equivalent voltage should be displayed. If not, adjust the S (scan) calibration screw.

CAUTION

These transducer probes have been designed for refrigeration systems. These instructions and related safety precautions must be completely read and understood before selecting, using or servicing these probes. Only knowledgeable, trained refrigeration mechanics should install, operate or service these probes. Stated temperature and pressure limits should not be exceeded. Probes should not be removed from receiver unless system has been evacuated to zero pressure.

WARNING: As with all electronic and mechanical components, there is a limited life expectancy. An expected life of seven to ten years is typical. This should be understood as only a suggested replacement time period. Actual condition and performance of electronics due to ambient conditions, quality of electrical current, voltage, etc. may necessitate a different replacement schedule. Regardless, probes should be inspected at least annually to insure their safe and continuous service. See also Safety Precautions in current List Price Bulletin and Safety Precaution Sheet supplied with product. Escaping refrigerant might cause personal injury, particularly to the eyes and lungs.

PRINCIPLES OF OPERATION

These probes are capacitance type level transducers. Capacitance is an electrical measurement which is commonly used to indicate an object's potential to store electricity. These objects usually consist of two electrodes with a medium separating them.

With Hansen level transducer probes, the teflon enclosed stainless steel rod acts as one electrode, the stainless steel perforated shielding tube (SHP models) or vertical receiver wall (SVP models) acts as the other, and separating them is the refrigerant liquid and vapor. Because the potential to store electricity is far greater for refrigerant liquid than that of vapor, capacitance changes nearly proportionally with the refrigerant liquid level. With this information, the electronics can calculate the percentage of the probe immersed in liquid refrigerant and supply an appropriate output signal.

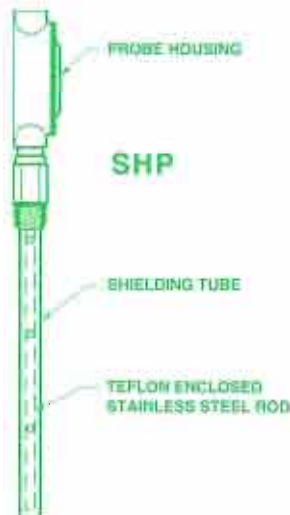

ORDERING INFORMATION, LEVEL TRANSDUCER PROBES

| FOR HORIZONTAL RECEIVERS | | |
|--------------------------|------------------|----------|
| CAT. NO. | INSERTION LENGTH | |
| SHP06 | 6" | (152 mm) |
| SHPO8 | 8" | (203 mm) |
| SHP12 | 12" | (305 mm) |
| SHP16 | 15.3" | (387 mm) |
| SHP20 | 19.2" | (487 mm) |
| SHP24 | 23.1" | (586 mm) |
| SHPXX | CUSTOM LENGTH | |

Horizontal Receiver Probes (SHP) should also be used in short, narrow or wide vertical receivers.

| FOR VERTICAL RECEIVERS | | |
|------------------------|------------------|-----------|
| CAT. NO. | INSERTION LENGTH | |
| SVP36 | 36" | (914 mm) |
| SVP48 | 48" | (1219 mm) |
| SVP54 | 54" | (1372 mm) |
| SVP60 | 60" | (1524 mm) |
| SVPXX | CUSTOM LENGTH | |

For vertical receivers 12" to 20" diameter

TO ORDER: Specify the catalog number, refrigerant and factory calibration: 0 to 5 volt or 1 to 6 volt. Custom Insertion Length probes and Heavy-duty Construction Option are available at an additional cost, but may take longer to manufacture and are nonreturnable.

For commercial refrigeration applications where electronic signals are not desired, the S series of probes are available to operate at line voltage with 2 adjustable 10 amp SPDT relays. This is the Level Cat option.

For industrial refrigeration applications which may require special electronic "noise" isolation, greater temperature range, cable length, control units, etc.; contact factory for information on industrial refrigeration level controls and monitoring devices—such as Vari-Level® Adjustable Level Controls with control unit and level probe, and Techni-Level® Transducer Probes with 4-20 mA output.

WARRANTY

Hansen electronics are guaranteed against defective materials or workmanship for 90 days F.O.B. factory. All other components are guaranteed for one year F.O.B. factory. No consequential damages or field labor is included.

HANSEN TECHNOLOGIES CORPORATION

6827 High Grove Boulevard
Burr Ridge, Illinois 60521 U.S.A.
Telephone: (708) 325-1565
Outside IL: 1-800-426-7368
FAX: (708) 325-1572