

## HANSEN TECHNOLOGIES CORPORATION



Level Pulse Control System (LPS)  
with Optional Strainer

### Specifications, Applications, Service Instructions & Parts

#### Level Pulse Control System (LPS)

#### Pulse-Width Modulated Liquid Level Control for Refrigerants

ISO 9002

### INTRODUCTION

The Level Pulse Control System (LPS) is a pulse-width modulating system that incorporates a sophisticated controller (PWC, PWCA) with a specially designed, high-cycle, long-life, pulse-width valve (PWV). Using a 4–20 mA input signal from a customer supplied level probe, the LPS modulates the flow of liquid to control liquid level, matches the supply of makeup liquid to the system load, and, most importantly, minimizes fluctuations in vessel pressure. The LPS is ideally suited for use with Hansen's Vari-Level (with MOD420) or Techni-Level (VLT) level probes.

### KEY FEATURES

- Stabilizes suction pressure and reduces unnecessary loading/unloading of compressors.
- Reduces pump disturbances and shutdowns due to cavitation.
- Auto-tune controller adapts to the operation of individual systems.
- Valve dampens on closing to minimize inlet liquid shock to piping and other system components.
- Tight seating shutoff.
- Has a reserve capacity for start-up and post defrost fill.
- Incorporates an adjustable capacity setting to accommodate system size or load changes without orifice replacement.

### APPLICATIONS

The Level Pulse Control System (LPS) is ideal for modulating liquid refrigerant to feed recirculator packages, pump accumulators, receivers, intercoolers, and surge drums connected to flooded heat exchangers and process equipment. The LPS can be used to replace existing float valves, motorized ball valves, pneumatic-controlled valves, and single solenoid valves.

### MATERIAL SPECIFICATIONS

#### Pulse-Width Valve

- Bodies: Ductile iron and cast steel
- Seats: Teflon
- Safe Working Pressure: 400 psig (27 bar)
- MOPD: 285 psi (19.7 bar)
- Refrigerant Temperature: –60°F to +240°F (–50°C to +115°C)
- Refrigerants: ammonia, R22, R134a, and other Hansen approved refrigerants

#### Controller

- Electrical: 24 to 28 VAC, 50/60 Hz, 60VA
- Input: 4–20 mA loop
- Impedance: 100 ohm
- Enclosure: Watertight, NEMA 4
- Ambient temperature: –20°F to +150°F (–29°C to +65°C); 90% RH Max

## OPERATION

The Level Pulse Control System (LPS) modulates the flow of liquid into a vessel. This is done by monitoring the deviation from the level set point and opening or closing a long-life solenoid valve during a repeating six second time span. The amount of time the valve is open during each six second cycle is proportional to how far the liquid level is from the set point. If the liquid level is greatly below the set point, the valve may stay open for the entire six seconds. As the level approaches the set point, the valve is open for less time during each six second cycle. When the level reaches the set point or above, the valve will not open during the six seconds. When the liquid level falls below the set point, the valve will open again.

LPS1, 2, and 3, sizes ¾" (20 mm) through 1½" (32 mm), have a single solenoid coil which energizes to open the valve, and de-energizes to close the valve.

LPS5, 2" (50 mm), has two solenoid coils, one to open and one to close. During operation, one of the two coils is energized at all times, but not both at the same time. The downstream coil is energized to open the valve, and the upstream coil is energized to close the valve.

## SIZING THE LPS

Select the appropriate Level Pulse Control System (LPS) using Chart A: LPS Capacity Ranges to find the correct catalog number. For example: 225 ton full load ammonia accumulator feed requires the Level Pulse Control System LPS3.

For widely fluctuating loads of greater than 5 to 1 full load to low load, two pulse-width valves with controllers in parallel, one level set point slightly higher than the other, are recommended. Contact the factory for more details.

For liquid feed applications from intermediate temperature to low temperature vessels, the LPS capacity (as shown in chart A) should be multiplied by a factor of 0.5 for the lower pressure drop.

## CHART A: LPS CAPACITY RANGES

Cat. No.	Capacity Ranges in Tons (kW)			
	Ammonia		R22	
LPS1	10 - 110	(35 - 387)	2.0 - 25	(7.0 - 88)
LPS2	15 - 185	(53 - 651)	3.0 - 40	(11 - 141)
LPS3	30 - 330	(106 - 1181)	6.0 - 70	(21 - 246)
LPS5	220 - 1000	(770 - 3500)	50 - 220	(180 - 770)

Capacities are based on 75% pulse on time, +86°F (+30°C) saturated liquid, and 0°F (-20°C) evaporating temperature. For R134a capacities, multiply R22 capacity by .73 (accuracy within 8%).

## INSTALLATION

The liquid line to the inlet of the pulse-width valve (PWV) should be sized for a maximum liquid refrigerant velocity of 7 feet/second for ammonia or 5 feet/second for R22. Liquid lines must be appropriately anchored, as is required with any liquid solenoid valve. Also, liquid lines should be free of vapor. Following these installation guidelines will help minimize liquid velocity shock (liquid hammer) in the pipe; refer to Chart B: Recommended PWV Inlet Line Size. Additionally, a riser with a gas space may be installed in the piping before the PWV to further minimize liquid hammer.

For liquid feed applications from intermediate temperature to low temperature vessels, the PWV should be positioned near the outlet of the intermediate temperature vessel to minimize the possibility of flash gas at the inlet of the valve. The outlet line to the low temperature vessel should be properly sized to take into account flash gas and liquid.

The optional strainer, for the 2" pulse-width valve, PWV5, cannot be close-coupled.

Separate isolation valves must be installed to facilitate servicing the PWV. The expansion valve portion of the PWV cannot be used to isolate the solenoid valve portion of the PWV for servicing because the pressure sensing tube of the PWV bypasses the seat of the expansion valve portion.

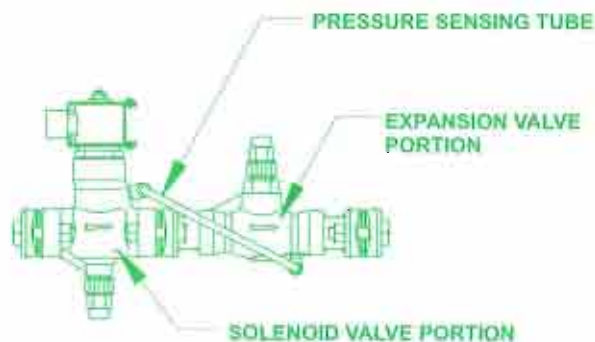

## CHART B: RECOMMENDED PWV INLET LINE SIZE\*

Line Size	Maximum Capacity Ammonia	Maximum Capacity R22
¾"	40 Tons (141 kW)	8.0 Tons (28 kW)
1"	80 Tons (281 kW)	15 Tons (53 kW)
1¼"	175 Tons (615 kW)	34 Tons (120 kW)
1½"	270 Tons (950 kW)	51 Tons (179 kW)
2"	620 Tons (2180 kW)	120 Tons (492 kW)
2½"	900 Tons (3165 kW)	190 Tons (809 kW)
3"	1400 Tons (5979 kW)	340 Tons (1407 kW)

Capacities are based on 75% pulse on time, 2 psi drop per 100 ft of equivalent line length, and a velocity limit of 7 ft/s for ammonia, and 5 ft/s for R22. For R134a, multiply R22 capacity by .73 (accuracy within 8%).

\*For applications with a large pressure drop across the pulse-width valve, attention must be paid to proper outlet line sizing to accommodate flash gas.

## TYPICAL APPLICATIONS

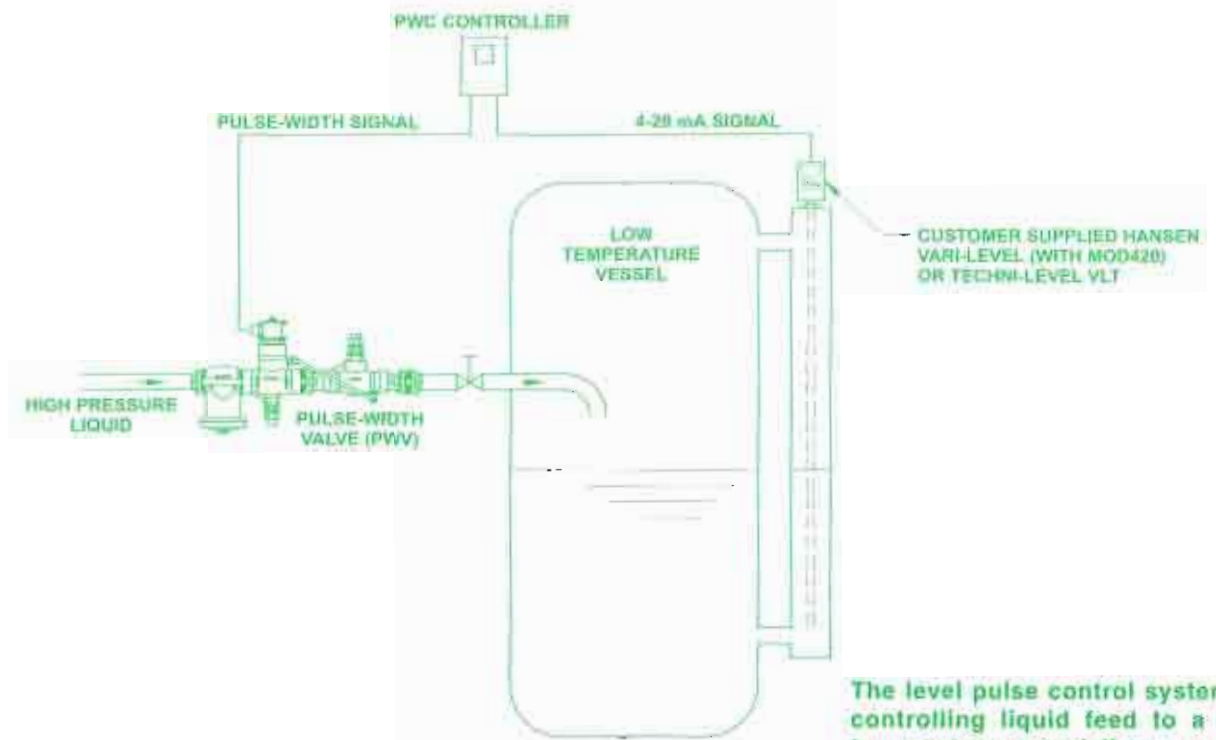

The level pulse control system is controlling liquid feed to a low temperature vessel (for example, a pump accumulator).

Low Temperature Vessel

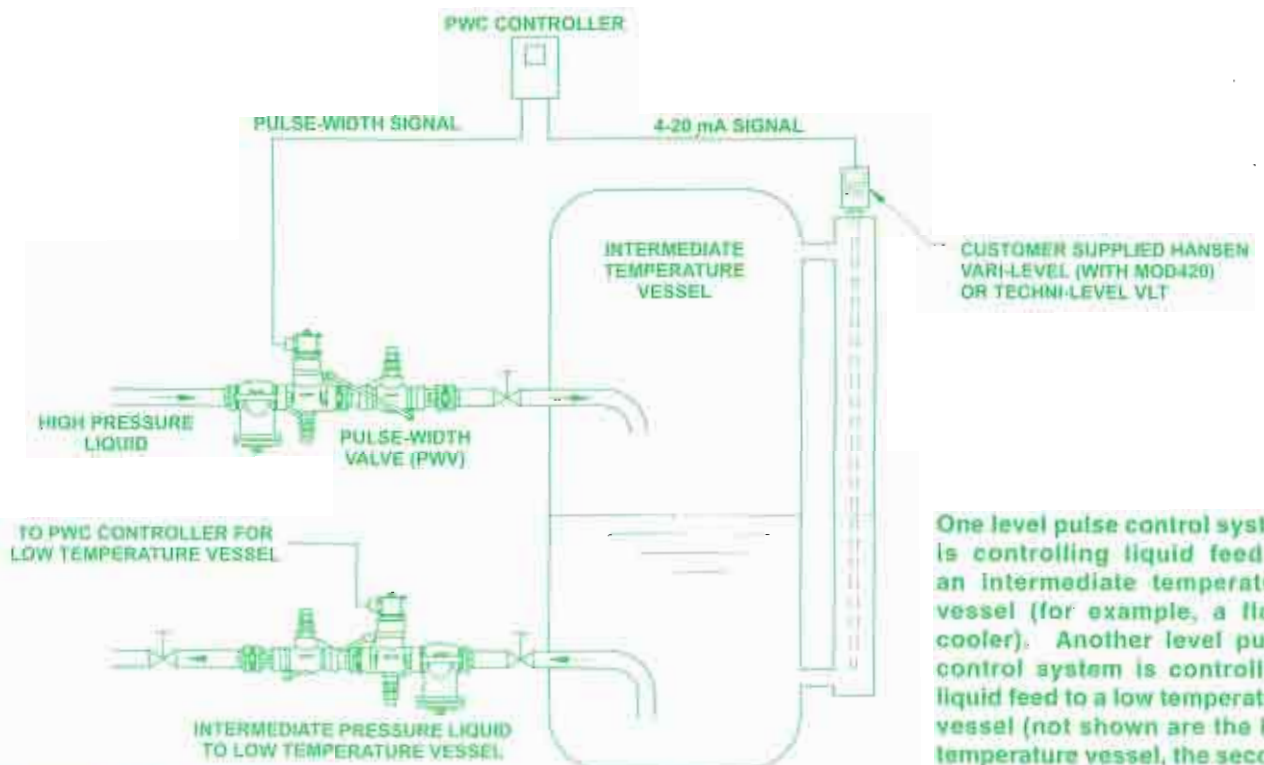

One level pulse control system is controlling liquid feed to an intermediate temperature vessel (for example, a flash cooler). Another level pulse control system is controlling liquid feed to a low temperature vessel (not shown are the low temperature vessel, the second level probe, and the second controller).

The drawings in this bulletin are for illustration purposes only and should not be used for actual engineering or installation.

Intermediate Temperature Vessel

## TYPICAL APPLICATIONS

PWC CONTROLLER

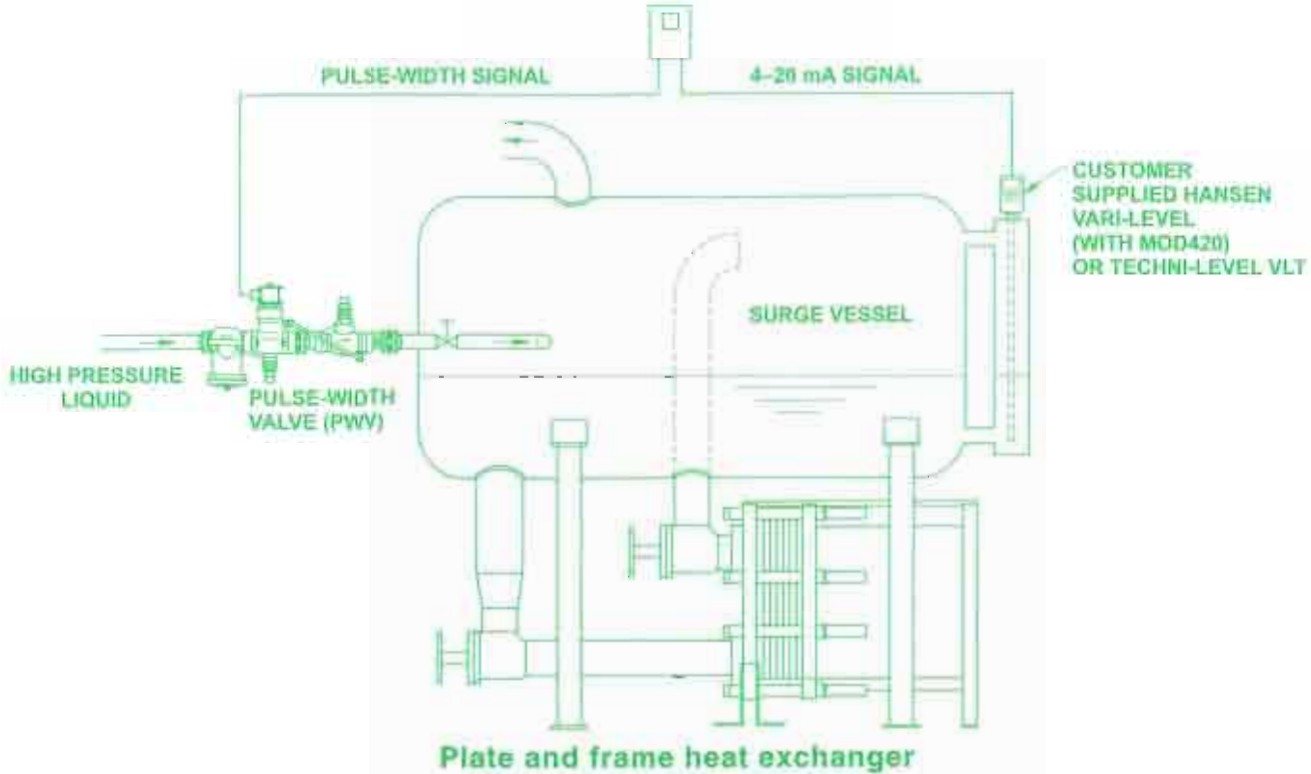

## INSTALLATION DIMENSIONS, INCH (MM)

3/4" thru 1 1/4" Pulse-Width Valves (PWV1, 2, & 3)

2" Pulse-Width Valve (PWV5)

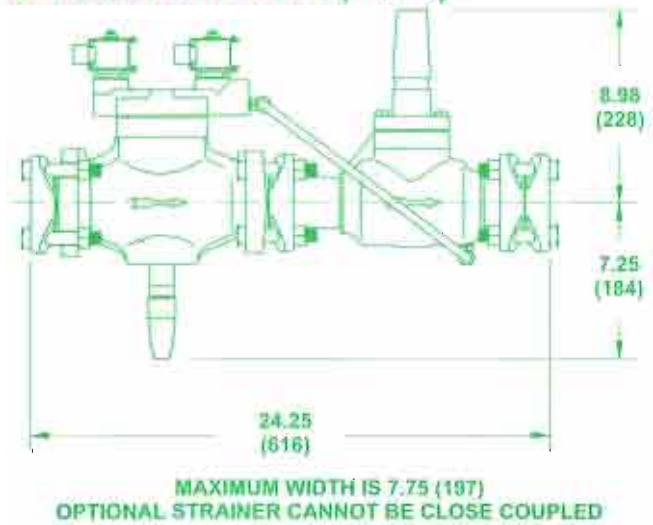
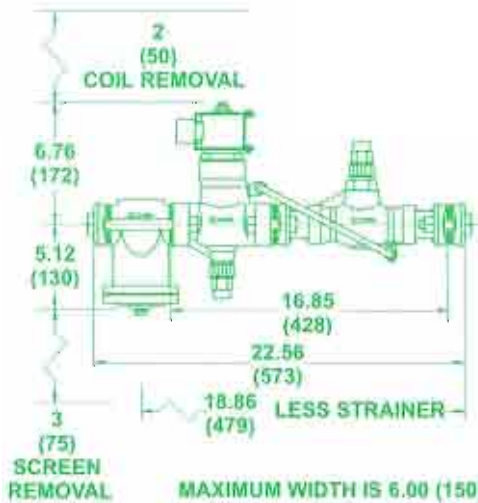

## Pulse-Width Controllers (PWC and PWCA)

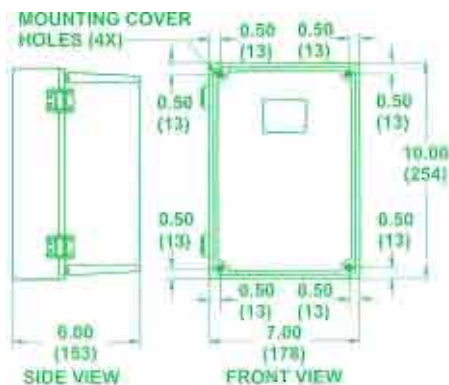

## TYPICAL WIRING

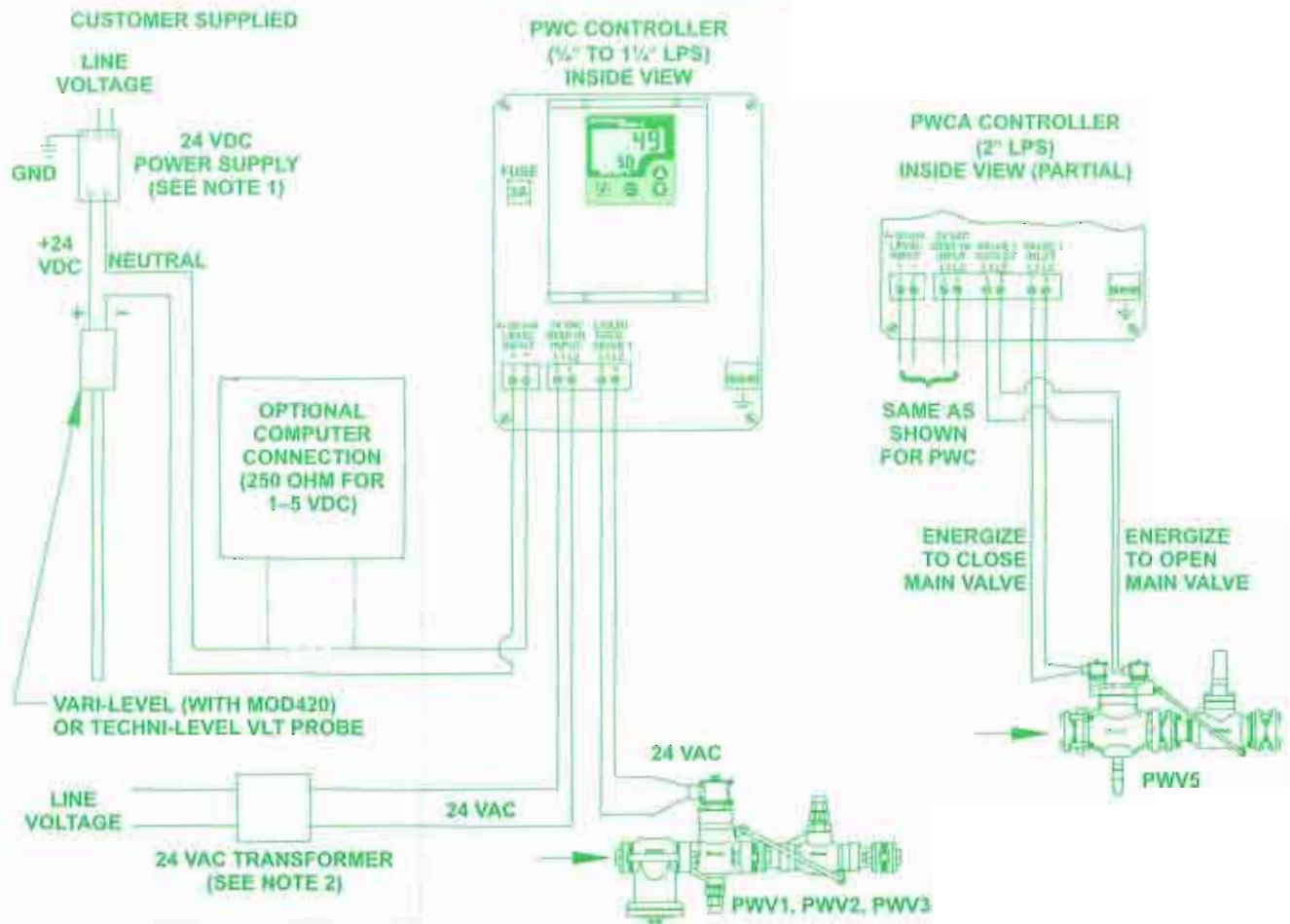

NOTE 1: OPTIONAL POWER SUPPLY (PART NO. PSU) AVAILABLE FROM HANSEN.  
 NOTE 2: OPTIONAL TRANSFORMER (PART NO. TR92) AVAILABLE FROM HANSEN.

## ELECTRICAL

The controller requires 24 VAC, 50/60 Hz, 60 VA minimum. A transformer should be selected with this output and the appropriate AC line voltage input. The appropriate transformer (TR92) can be purchased from Hansen if needed. The pulse-width valve solenoid coil draws approximately 19 watts from the controller. To ensure adequate voltage at the solenoid coil, determine the appropriate 24 VAC wire size based on the distance from the 24 VAC transformer to the controller plus the distance from the controller to the pulse-width valve.

Distance (feet)	Wire Size (AWG)
100	18
150	16
250	14

The standard encapsulated coil connection is a ½" fitting (NPSM) for conduit with 18" (450 mm) pigtail leads. Coils with DIN plug, Quick Disconnect Coil, or Coil with Junction box are available. Contact the factory. All coils are encapsulated and have a standard corrosion resistant, plated, steel housing which meets NEMA 3R (rainproof) and NEMA 4 (splashproof, approximately IP65) requirements. The junction box is NEMA 1. The coil should only be energized while on solenoid tube, otherwise the coil may quickly

burnout. To avoid bending the solenoid tube, remove the coil from the valve before tightening any conduit connection.

Additionally, the level probe requires a 24 VDC regulated output power supply with a minimum of 25 mA current output. A power supply unit should be selected with this output and the appropriate AC line voltage input. The appropriate power supply unit (PSU) can be purchased from Hansen if needed.

## OPTIONAL COMPUTER CONNECTION

If desired, the level pulse control system (LPS) can be connected to a computer for monitoring liquid level. Refer to the schematic above for wiring. For more information on using a Hansen level probe with a computer, refer to the appropriate Hansen technical bulletin (Vari-2 or P109).

If the LPS is connected to a computer and the computer goes down or power is lost at the computer, the LPS will continue to function normally in nearly all cases. Until corrective action is taken on the computer, information normally sampled by the computer will be unavailable. Once the computer problem is corrected, operation will return to normal. No additional steps normally need to be performed on the LPS.



## SETTING THE PULSE-WIDTH VALVE

Once the pulse-width valve is installed in the line and the controller correctly wired, set the PWV for optimal operation. Based on the system capacity and the selected LPS, determine the best setting (turns open) from Chart C.

For example: The correct model for a 225 ton ammonia accumulator feed system is LPS3, as described earlier. The correct setting for the LPS3 pulse-width valve in this example is approximately 5 turns open (229 tons), as shown in Chart C.

Remove the seal cap from the capacity-adjusting stem and turn the stem fully closed (clockwise). Then, rotate the stem open (counterclockwise) the correct number of turns, in this case five. Replace the seal cap. The controller can now be set.

## SETTING THE CONTROLLER

Apply power to the controller. The valve will operate to adjust the liquid level to the factory preset of 25%. To set the controller for a different level, use the UP  or DOWN  button until the desired set point level is displayed in the lower readout. This can be done while the valve is operating. The upper readout shows the actual level percentage in the level column.

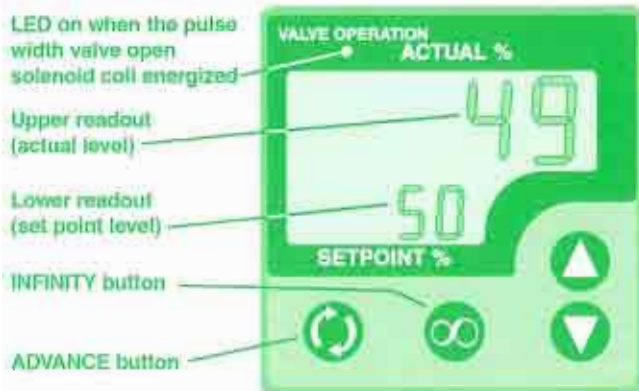

With the pulse-width valve properly adjusted to the correct "turns open" setting, allow the system to reach the desired actual liquid level. The controller is operating in a proportional mode. When the system is at full nominal load, proceed to the Auto-tune cycle, as described in the next section.



Controller Face

## AUTO-TUNE CYCLE

The Auto-tune cycle is used by the controller to "learn" the characteristics of the individual system. Auto-tune is a calibration process that enables the controller to perform optimally in maintaining a stable liquid level. The system should be at nominal full load with no coils in defrost and the liquid should be at the desired level when performing Auto-tune.

Depress the ADVANCE button once. The *PB* prompt is displayed in the lower readout. If the value in the upper readout is 0, use the UP  button to change the setting to any value other than 0. Depress the ADVANCE button again to display the *AUT* prompt in the lower readout. Press the UP  button once to change the upper readout from *OFF* to *TUNE*. Press

## CHART C: LPS SETTING BY CAPACITY IN TONS (kW)

Cat. No.	Turns Open, Ammonia				
	2	3	4	5	6
LPS1	12 (42)	28 (98)	52 (183)	80 (281)	114 (401)
LPS2	17 (60)	35 (123)	68 (239)	125 (440)	188 (661)
LPS3	17 (60)	52 (183)	114 (401)	229 (805)	331 (1164)
LPS5	228 (802)	428 (1508)	628 (2208)	828 (2911)	1027 (3613)

Cat. No.	Turns Open, R22				
	2	3	4	5	6
LPS1	2.5 (8.6)	6.3 (22)	12 (42)	18 (63)	25 (88)
LPS2	3.8 (13)	7.5 (26)	15 (53)	28 (98)	42 (148)
LPS3	3.8 (13)	12 (42)	25 (88)	51 (179)	73 (257)
LPS5	51 (178)	95 (333)	139 (486)	183 (643)	227 (799)

Capacities are based on 75% pulse on time, +86°F (+30°C) saturated liquid, and 0°F (-20°C) evaporating temperature. For R134a capacities, multiply R22 capacity by .73 (accuracy within 8%).

the INFINITY button to return to the normal display and begin the Auto-tune cycle.

During the Auto-tune cycle, the upper readout alternates between the actual liquid level percentage and the *TUNE* prompt. During the tuning cycle, there may be a wide downward swing in liquid level in the vessel. This is normal. The level will return to the level set point on completion of the Auto-tune cycle. Auto-tune typically takes one to two minutes, but may take longer depending on the system.

After the Auto-tune cycle is complete, the controller automatically returns to the normal operation mode, as indicated when the upper readout stops alternating to the *TUNE* prompt and displays only the actual liquid level. The Level Pulse Control System is now calibrated and in the normal operation mode.

## RE-ADJUSTMENT

The level pulse system is designed to operate satisfactorily under varying load conditions. However, re-adjustment of the pulse-width valve capacity setting may be desired in some cases, such as a sustained substantial load change. This is easy, since the valve has an adjustable orifice. Pump out is not required to change the capacity setting of the Hansen pulse-width valve. Simply remove the seal cap from the capacity-adjusting stem and change the setting as necessary, see Chart C. Then perform the Auto-tune cycle. It is important to perform the Auto-tune cycle whenever the capacity setting is substantially changed. Replace the seal cap and observe the system operation to verify that the adjustment was adequate.

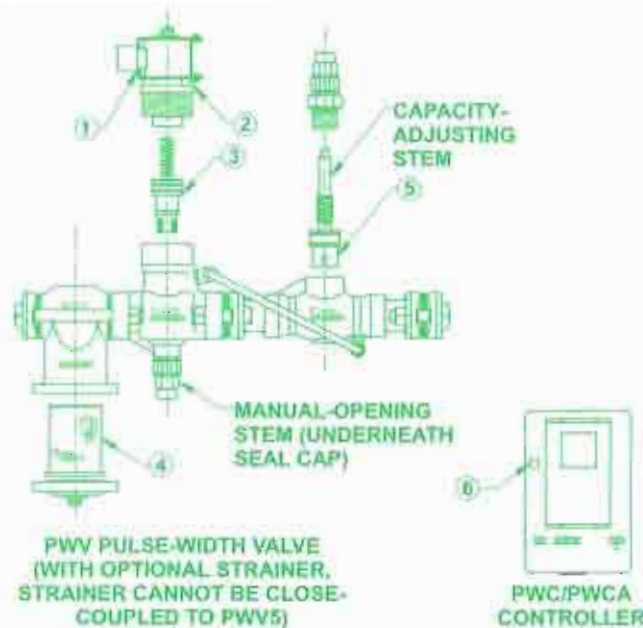

### SERVICE CODES

The PWC and PWCA controllers automatically display service codes when necessary. These codes are displayed on the controller digital readouts.

The most common codes are listed in the chart below. When the controller displays a service code, make note of the code and consult the chart. Perform the corrective action indicated and observe the operation of the controller to verify normal operation.

If the controller continues to display the service code or a service code appears that is not listed in the chart, turn power to the controller off, then on. If the service code continues to appear, contact the factory.

### PARTS LIST

Item	Description	Catalog Number
1	<b>Solenoid Coil Kit, 24V, 1/2" Fitting</b> Above kit consists of: Bare Coil Coil Housing Assembly Kit Coil Washer Coil Nut	70-1058*
2	<b>Solenoid Tube/Plunger Kit, PWV</b> Above kit consists of: Plunger Assembly with Seals Solenoid Tube Solenoid Tube Gasket Tube Screws Coil Washer Coil Nut	70-1072*
3	<b>Piston Assembly Kit</b> For PWV1, PWV2, PWV3 For PWV5 Above kit consists of: Piston Assembly Closing Spring Upper Body O-ring/Gasket Lower Body O-ring (n/a for PWV5)	70-1073 70-1078
4	<b>Strainer Screen Kit for ST100</b> <b>Strainer Screen Kit for ST250</b> Above kits consist of: Screen Assembly Bottom Cover Gasket	78-1003 78-1006
5	<b>Throttling Plug Kit, PWV1</b> <b>Throttling Plug Kit, PWV2</b> <b>Throttling Plug Kit, PWV3</b> <b>Throttling Plug Kit, PWV5</b> Above kits consist of: Throttling Plug Ball Bearings Ball Retainer Bonnet O-ring/Gasket	50-1079 50-1015 50-1016 50-1047
6	3 amp fuse	20-1698

\*Requires two (2) for PWV5 if servicing both inlet and outlet.

### CONTROLLER SERVICE CODES & TROUBLESHOOTING

Code/Problem	Probable Cause	Action
Blank Readout	Power to the unit may be off, wiring broken, or incorrect input power.	Check switches, breakers, connectors, and other items to verify "on" position and operating condition. Verify correct input power.
ERR 1 or ERR 2	The 4-20 mA probe or control loop may be improperly wired, reversed, shorted, or open.	Check the probe connections and wiring for proper installation and condition of connections and wiring.
ERR 3 or ERR 4	Current in the 4-20 mA probe control loop may be too high.	Verify the probe output current for a 4-20 mA signal. Verify that the ambient temperature at the controller is within specifications.
ERR CAL	The calibration data is corrupt.	Perform Auto-tune on the controller.
Controller will not exit Auto-tune	Refrigeration system operating at low load with insufficient level change for Auto-tune.	To force controller out of Auto-tune and return to previous settings, depress the ADVANCE button twice to display the <i>OUT</i> prompt in the lower readout. Press UP  button once to change the upper readout from <i>TUNE</i> to OFF. Press the INFINITY button once to return to the normal display. Repeat Auto-tune with system at full nominal load.
Refrigerant level grossly overshoots & undershoots set point	Incorrect or inadequate Auto-tune settings.	To get the refrigerant level stable, it may be necessary to return to the factory set proportional band of 3. Depress the ADVANCE button once to display the <i>PSI</i> prompt in the lower readout. Use the UP  and DOWN  buttons to change the upper readout to 3. Press the INFINITY button once to return to the normal display.
No voltage at solenoid coil	Fuse in PWC/PWCA is blown.	Check if coil is burned out. Replace fuse.

For other service codes, contact the factory.

## VARI-LEVEL® ADJUSTABLE LEVEL CONTROLS FOR REFRIGERANTS

The Hansen Vari-Level® consists of a level probe for a 3" or 4" pipe level column plus a solid-state control unit for ON-OFF of up to five individual, relay operated level control points. Three commonly used control points are a high alarm/cutout, operating level, and low alarm/cutout. A 4-20 mA output module, MOD420, is available for all Vari-Levels for use with the Hansen Level Pulse Control System.

A bright digital LED displays percent level in vessel. Each level control point is adjustable for height and operating differential with a built-in level simulator. The standard electrical input is 115V, 50/60Hz; 230V, 50/60Hz is available. Suitable for ammonia, R22, R134a and other compatible refrigerants.



### CAUTION

Hansen products are for refrigeration systems only. These instructions and related safety precautions must be read completely and understood before selecting, using, or servicing the product. Only knowledgeable, trained refrigeration technicians should install, operate, or service the products. Stated temperature and pressure limits should not be exceeded. Components should not be removed from the system unless the system has been evacuated to zero pressure. See also the Safety Precautions in the current List Price schedule and the Safety Precautions Sheet supplied with this product. Escaping refrigerant can cause injury, especially to the eyes and lungs.

### WARRANTY

Hansen electrical and electronic items are guaranteed against defective materials and workmanship for 90 days F.O.B. our plant. All other components are guaranteed for one year F.O.B. our plant. No consequential damages or field labor is included.

## TECHNI-LEVEL® (VLT) LEVEL TRANSDUCER PROBES

These specially-designed level transducer probes with 4-20 mA isolated output are for refrigerant level control in computer operated plants or connection to a Hansen Level Pulse Control System. All transducer electronics are compact and located on top of probe. Fifty feet (15 m) of two wire cable is included with the probe. The level column connection on the probe is 1/2" MPT. Suitable for ammonia, R22, R134a and other compatible refrigerants.



## ORDERING INFORMATION, LEVEL PULSE CONTROL SYSTEM

Cat. No.	Nominal Size inches (mm)	Flange Connection Styles and Sizes		
		FPT, SW, WN		ODS
		Standard	Also	Standard
LPS1	1/2 (20)	1/2	1, 1 1/2	1/2
LPS2	1 (25)	1	1 1/2, 1 3/4	1 1/2
LPS3	1 1/2 (32)	1 1/2	1 3/4, 1 3/8	1 3/4
LPS5	2 (50)	2	1 3/4	2 1/2

The Level Pulse Control System (LPS) includes a pulse-width valve (PWV) and a controller (PWC or PWCA).

**TO ORDER:** Specify the catalog number of the controller and the valve, the required nominal capacity (tons or kW), refrigerant, connection style and size, and recommended optional strainer.

**OPTIONS:** Recommended strainer; for LPS1, 2, and 3 use ST100, for LPS5 use ST250 with flanges. A 115VAC/230VAC: 24VAC transformer is available to power the controller. Specify part number TR92 if needed. A 115VAC/230VAC: 24VDC power-supply unit is available to power the level probe. Specify part number PSU if needed.

Also available is a reverse acting valve that maintains the level in a vessel by controlling the flow out of the vessel. Contact the factory for more details.

### WARNING

The PWC/PWCA has built-in multiple control capabilities for other industries. Hansen has programmed the controller for the particular use described in this bulletin. Do not attempt to penetrate barriers to other programming.

## HANSEN TECHNOLOGIES CORPORATION

6827 High Grove Boulevard  
Burr Ridge, Illinois 60521 USA  
Telephone: 630-325-1565  
Toll-free: 800-426-7368  
FAX: 630-325-1572  
E-mail: info@hantech.com  
Web site: www.hantech.com