



*Model HPT717
Pressure/Temperature Transducer*

INTRODUCTION

Temperature and pressure determine whether a refrigerant is at saturation, superheat, or subcooling. The Hansen Pressure/Temperature Transducer measures both temperature and pressure within a single sensor. Electronics in the sensor then calculate the superheat or subcooling for the specified refrigerant. This value is converted to a milliamp signal for use by a customer supplied computer or controller.

APPLICATIONS

Measurement of superheat to control an electronic expansion valve for a DX evaporator.

Measurement of subcooling.

Measurement of non-condensable gas in a refrigeration system, which because it has a pressure higher than expected at the given temperature looks like subcooling.

Measurement of superheat to monitor/control de-superheater temperature.

Measurement of superheat to monitor/control suction gas temperature to compressor.

Specifications, Applications, Service Instructions & Parts

PRESSURE/ TEMPERATURE TRANSDUCER

4-20 mA Output of Superheat / Subcooling

KEY FEATURES

Specifically designed for industrial refrigeration

Replaceable solid-state electronics

Computer compatible, 2-wire 4-20 mA signal output

DIN plug standard, or optional 1/2" NPSM Quick Disconnect

Standard single 3/4" NPT fitting to system

Watertight NEMA 4 (IP65) enclosure

Standard model is suitable for ammonia

Also suitable for R22, R134a, and many other refrigerants with the appropriate refrigerant key

SPECIFICATIONS

Supply Voltage: 12-30 VDC

Signal Output: 4-20 mA proportional to superheat or subcooling (see page 2)

Maximum Load Resistance: 1200 Ohms at 24 VDC

Ambient Temperature Range: -20°F to +125°F
(-30°C to +50°C)

Refrigerant Temperature: -35°F to +150°F
(-37°C to +65°C)

Enclosure: NEMA 4, watertight (IP65)

Accuracy: +/- 1°F (0.6°C) superheat / subcooling

Safe Working Pressure: 400 psig (27 bar)

ADVANTAGES

Because the superheat or subcooling is calculated right in the transducer head, control systems are greatly simplified. A standard PLC or off-the-shelf PID controller can be used with this sensor. Combining the temperature measurement and pressure measurement in one sensor simplifies installation. Having the temperature sensor extend into the fluid flow greatly increases the accuracy and response time of the temperature measurement.

PRINCIPLES OF OPERATION

A precision thermistor in the extension tube accurately measures the refrigerant temperature. A precision, temperature compensated, pressure transducer in the transducer body accurately measures the refrigerant pressure. Electronics within the transducer head convert these measurements to a superheat or subcooling value. Data for the refrigerant properties of ammonia are stored on the base circuitry. Data for the refrigerant properties of many other refrigerants including R22, and R134a are stored on refrigerant keys that plug into the circuit board inside the NEMA 4 electrical enclosure. When one of the keys is plugged into the circuit board, the electronics use the data for the refrigerant specified by the key, instead of the ammonia data. The superheat or subcooling value is then converted to a mA output signal. 12 mA output corresponds to saturation (i.e. zero superheat, zero subcooling). 4 mA corresponds to 30°F (16.7°C) subcooling. 20 mA output corresponds to 30°F (16.7°C) superheat.

HPT SENSOR OUTPUT SIGNAL

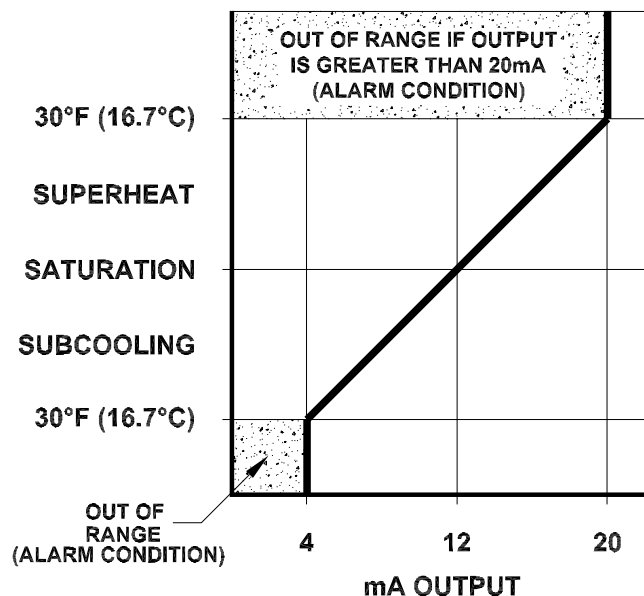

INSTALLATION

For vapor flow install the transducer so that the tip of the extension tube is in the flow stream, for the most accurate measurement. For mixed liquid and vapor flow, install the transducer so that the tip of the extension tube is near the bottom of the flow so that it is most likely to be in liquid, for the most accurate measurement. See sketch below. For liquid flow, the installation location is less critical, but having the tip in the flow is recommended.

Ensure there is enough clearance for the extension tube insertion length. The insertion length can not be changed in the field.

Tighten the 3/4" NPT fitting with the 1-1/2" (38 mm) across the flats hex only. Use appropriate pipe thread sealant. Do not turn the 1-1/2" round section with a pipe wrench. A pipe wrench on the 1-1/2" round section may severely damage or break the transducer.

Insulate pipe one foot on each side of Pressure/Temperature Transducer to minimize the effects of ambient temperature.

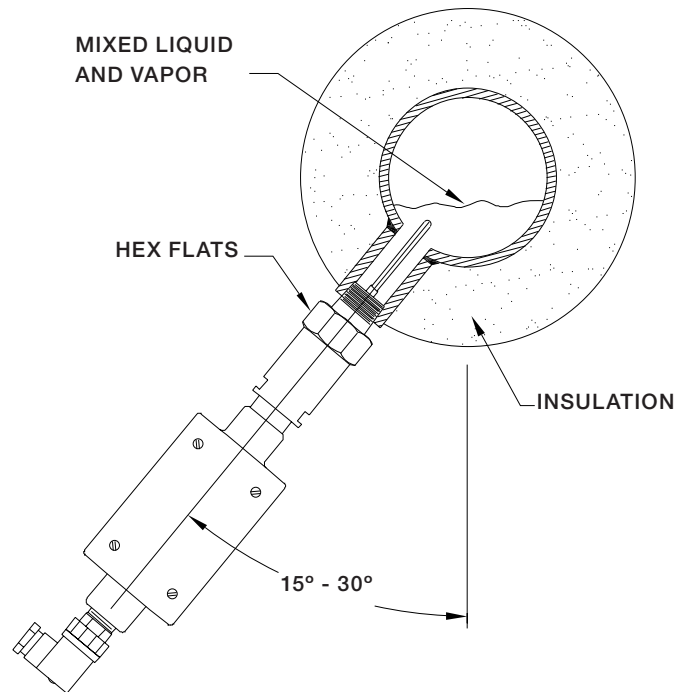

ELECTRICAL

The Pressure/Temperature Transducer is a two wire, loop powered, 4-20 mA device. A 24 VDC power supply is required for the milliamp loop circuit, but no additional power wires are required for the Pressure/Temperature Transducer. See Typical Wiring Diagram.

RESPONSE TIME

The Hansen HPT Pressure/Temperature Transducer is designed to have very fast response time to changes in temperature and pressure. This feature enhances control of direct expansion evaporator liquid feed valves. However, many applications do not demand a quick response (ie. non-condensable gas in condensers). Momentary changes in pressure may give transient high output readings of subcooling or superheat. The controls designer should take into consideration this possibility and build into the control system time averaging, time delay, or PID control logic to minimize potential disruptions to the refrigeration system.

ALARMS

The HPT Pressure/Temperature Transducer measures sub-cooling to 30°F(16.7°C) below saturation temperature or to 30°F(16.7°C) superheat above saturation temperature. Above or below these values, alarms may be necessary to prevent potential refrigeration system problems. It is up to the system designer to determine if alarms are required. A reading of 4 mA or less is out of range of the transducer. A reading of 20mA or more is out of range of the transducer.

TYPICAL WIRING DIAGRAM

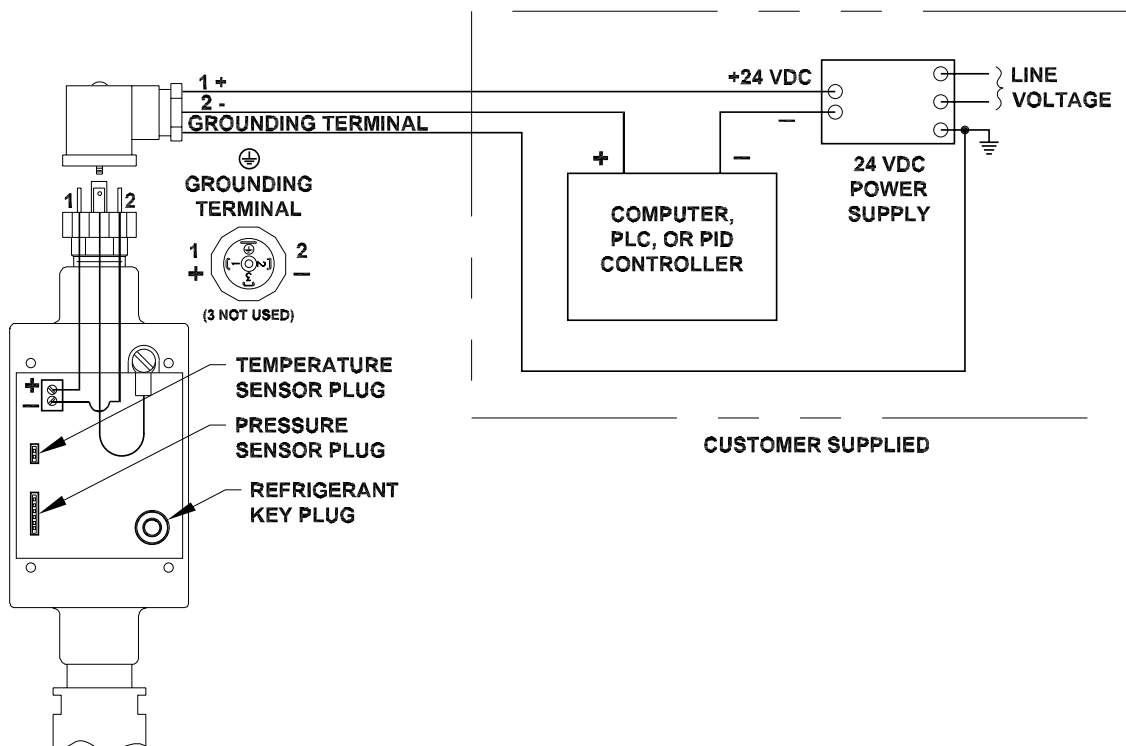

The drawings in this bulletin are for illustration purposes only and should not be used for actual engineering or installation. Not to scale.

APPLICATION: DIRECT EXPANSION EVAPORATOR

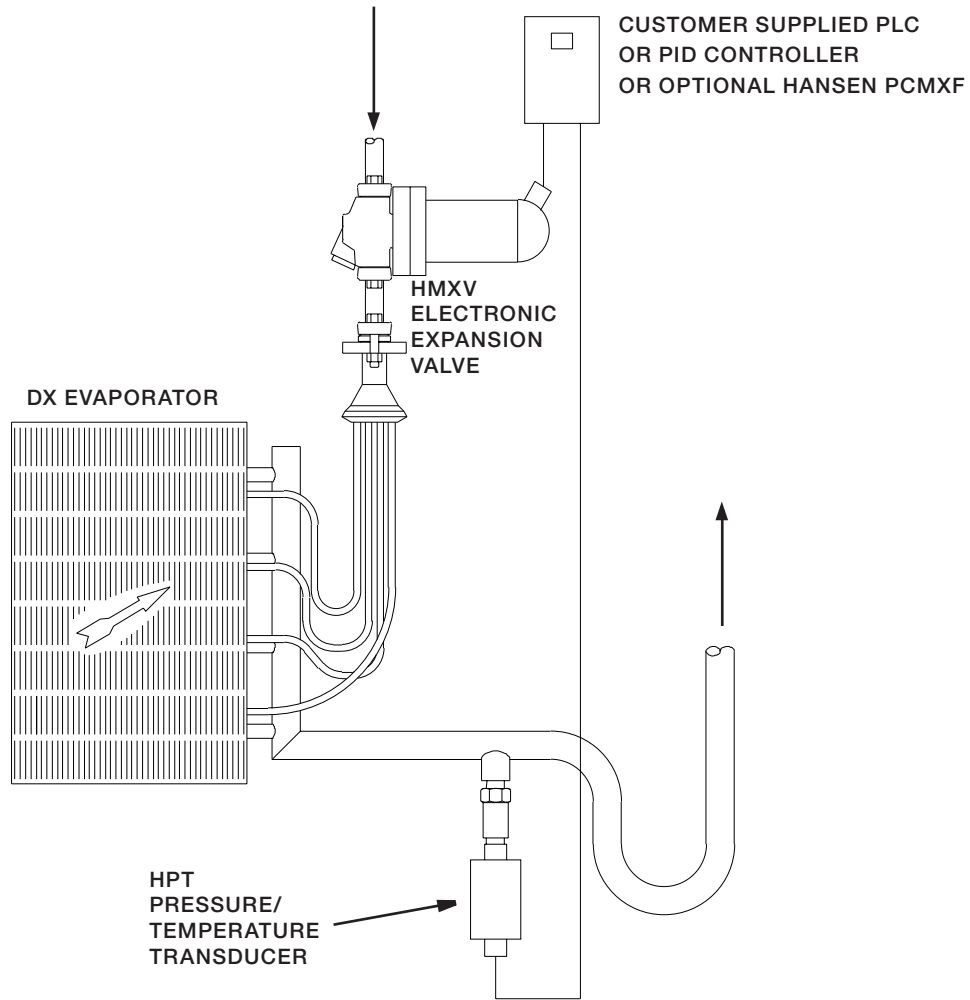

APPLICATION: NON-CONDENSIBLE GAS SENSING

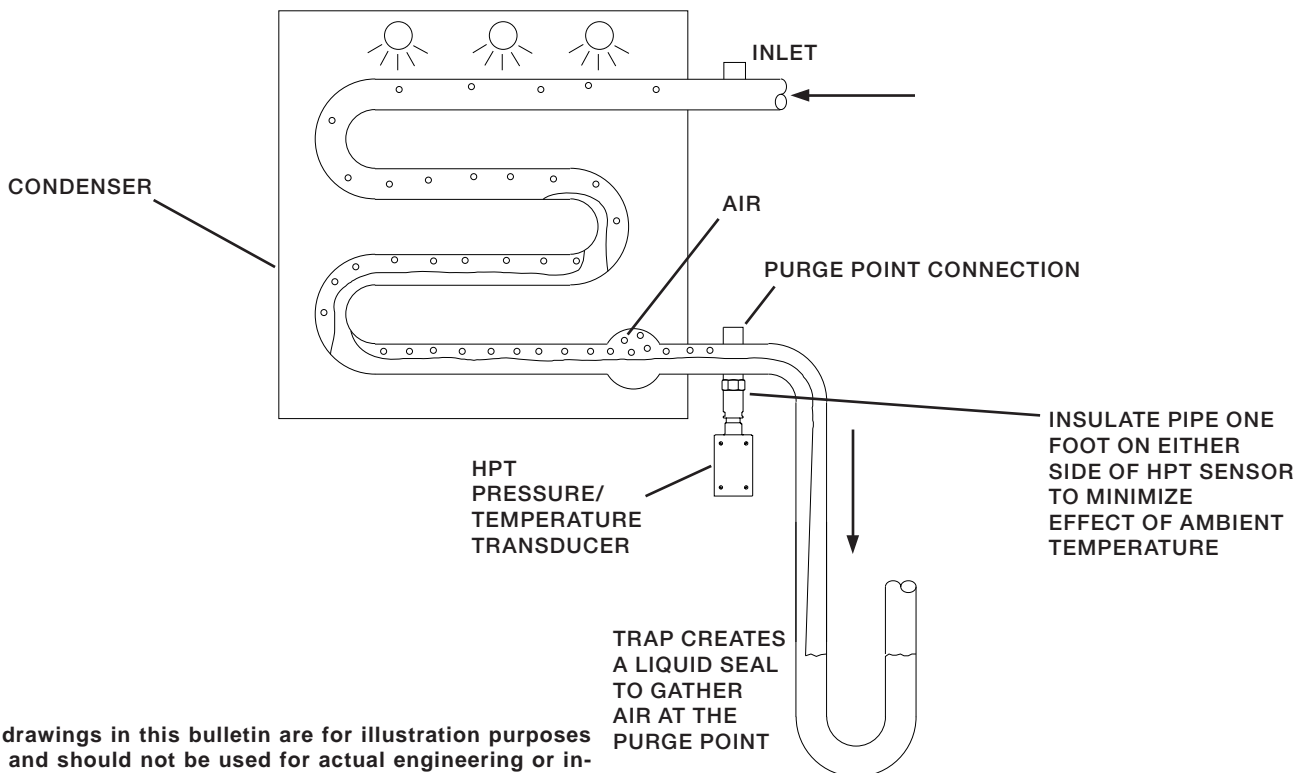

The drawings in this bulletin are for illustration purposes only and should not be used for actual engineering or installation. Not to scale.

APPLICATION: SUB-COOLED LIQUID

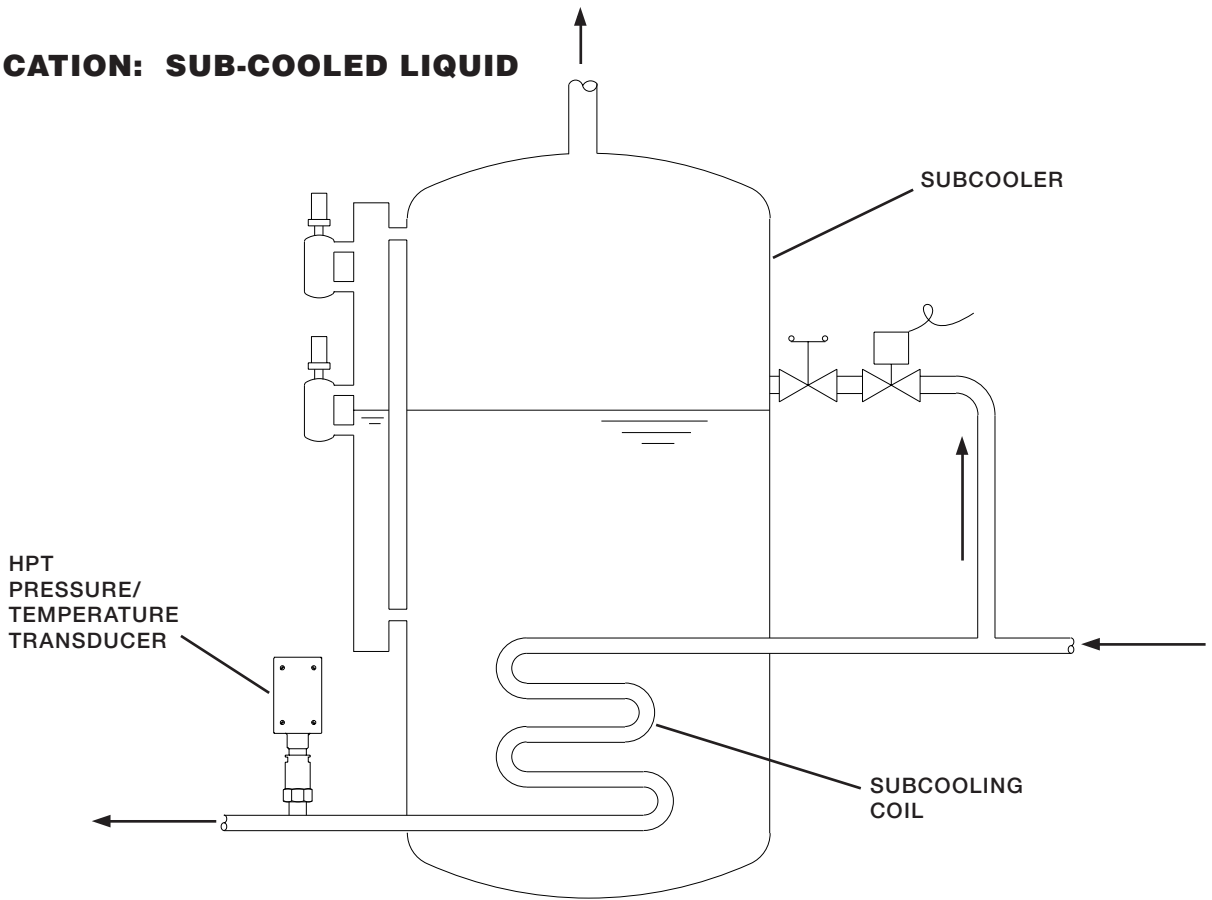

APPLICATION: MONITOR SUPERHEAT TO COMPRESSOR SUCTION

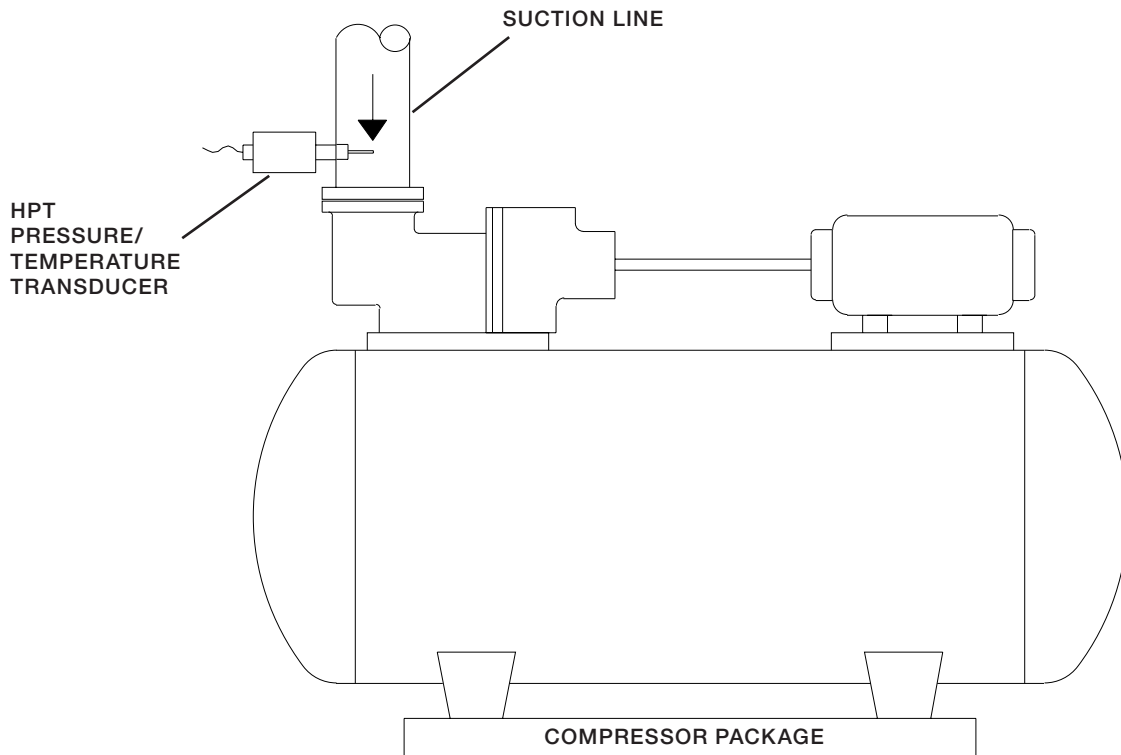

The drawings in this bulletin are for illustration purposes only and should not be used for actual engineering or installation. Not to scale.

INSTALLATION DIMENSIONS
INCHES [MILLIMETERS]

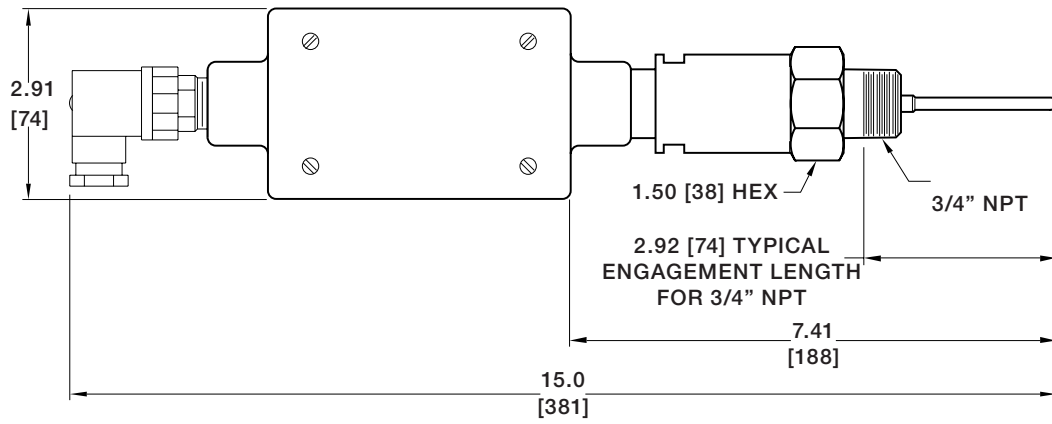

MILLIAMP OUTPUT TABLES

REFRIGERANT CONDITION	SUPERHEAT/SUBCOOLING °F	MILLIAMP OUTPUT
Out of Range		> 20
Superheat Degrees from Saturation Point	30	20.0
	29	19.7
	28	19.5
	27	19.2
	26	18.9
	25	18.7
	24	18.4
	23	18.1
	22	17.9
	21	17.6
	20	17.3
	19	17.1
	18	16.8
	17	16.5
	16	16.3
	15	16.0
	14	15.7
	13	15.5
	12	15.2
11	14.9	
10	14.7	
9	14.4	
8	14.1	
7	13.9	
6	13.6	
5	13.3	
4	13.1	
3	12.8	
2	12.5	
1	12.3	
Refrigerant at Saturation Point		12.0
Subcooled Degrees from Saturation Point	1	11.7
	2	11.5
	3	11.2
	4	10.9
	5	10.7
	6	10.4
	7	10.1
	8	9.9
	9	9.6
	10	9.3
	11	9.1
	12	8.8
	13	8.5
	14	8.3
	15	8.0
	16	7.7
	17	7.5
	18	7.2
	19	6.9
	20	6.7
	21	6.4
22	6.1	
23	5.9	
24	5.6	
25	5.3	
26	5.1	
27	4.8	
28	4.5	
29	4.3	
Out of Range	30	≤ 4.0

REFRIGERANT CONDITION	SUPERHEAT/SUBCOOLING °C	MILLIAMP OUTPUT
Out of Range		> 20
Superheat Degrees from Saturation Point	16.5	19.9
	16.0	19.7
	15.5	19.4
	15.0	19.2
	14.5	19.0
	14.0	18.7
	13.5	18.5
	13.0	18.2
	12.5	18.0
	12.0	17.8
	11.5	17.5
	11.0	17.3
	10.5	17.0
	10.0	16.8
	9.5	16.6
	9.0	16.3
	8.5	16.1
	8.0	15.8
	7.5	15.6
	7.0	15.4
	6.5	15.1
	6.0	14.9
	5.5	14.6
	5.0	14.4
	4.5	14.2
	4.0	13.9
	3.5	13.7
	3.0	13.4
2.5	13.2	
2.0	13.0	
1.5	12.7	
1.0	12.5	
0.5	12.2	
Refrigerant at Saturation Point		12.0
Subcooled Degrees from Saturation Point	0.5	11.8
	1.0	11.5
	1.5	11.3
	2.0	11.0
	2.5	10.8
	3.0	10.6
	3.5	10.3
	4.0	10.1
	4.5	9.8
	5.0	9.6
	5.5	9.4
	6.0	9.1
	6.5	8.9
	7.0	8.6
	7.5	8.4
	8.0	8.2
	8.5	7.9
	9.0	7.7
	9.5	7.4
	10.0	7.2
	10.5	7.0
	11.0	6.7
	11.5	6.5
	12.0	6.2
	12.5	6.0
	13.0	5.8
	13.5	5.5
	14.0	5.3
14.5	5.0	
15.0	4.8	
15.5	4.6	
16.0	4.3	
Out of Range	16.5	< 4.1

CAUTION

The Hansen Pressure/Temperature Transducers are for refrigeration systems only. These instructions and related safety precautions must be completely read and understood before selecting, using, or servicing these transducers. Only knowledgeable, trained refrigeration technicians should install, operate, or service these transducers. Stated temperature and pressure limits should not be exceeded. Transducer bodies should not be removed from the system unless the system has been evacuated to zero pressure. Escaping refrigerant can cause injury, especially to the eyes and lungs.

WARNING: As with all electronic and mechanical components, there is a limited product life expectancy. An expected life of seven to ten years is typical. This should be understood as only a suggested replacement time period. Actual condition and performance of electronics due to ambient conditions, quality of electrical current, voltage, etc., may necessitate a different replacement schedule. Regardless, transducers should be inspected at least once a year to ensure their safe and continuous service. See also Safety Precautions in the current List Price Bulletin and the Safety Precautions Sheet supplied with this product.

TROUBLESHOOTING GUIDE

The Pressure/Temperature Transducers are simple, solid-state devices. In the event that a problem should arise, the following guidelines should be followed for troubleshooting the probe.

Make sure that the actual conditions match the calibration conditions. The refrigerant that the probe is calibrated for is ammonia, unless a refrigerant key is plugged into the circuit board. The refrigerant type is stamped on the key.

It is very important to prevent moisture from entering the transducer housing at all times. Take steps to ensure that the internal electronics stay dry during storage, installation, and operation. Moisture inside the probe housing can damage the transducer electronics.

If the electronics are damaged, they may be replaced while leaving the transducer body installed in the refrigeration system. The temperature sensor and the pressure sensor connect electrically to the circuit board with plug-in connectors. Simply unplug the output connector, disconnect the plugs for the temperature and pressure sensors, replace the electronics, and reconnect the plugs and output wiring. No recalibration is required.

ORDERING INFORMATION

CATALOG NUMBER	DESCRIPTION
HPT717	Pressure/Temperature Transducer with 4-20mA output for ammonia
HPT22	For R-22
HPT134	For R-134a
HPT290	For Propane
HPT404	For R-404A
HPT507	For R-507A
HPT744	For CO2

TO ORDER

Specify catalog number. DIN Plug is standard, optional 1/2" NPSM Quick Disconnect Plug is available; specify when ordering. For other refrigerants, consult factory.

WARRANTY

Hansen electronics are guaranteed against defective materials or workmanship for 90 days F.O.B. our factory. All other components are guaranteed for one year F.O.B. our factory. No consequential damages or field labor is included.

TYPICAL SPECIFICATIONS

"The Pressure/Temperature Transducer shall measure pressure and temperature in a single sensor, calculate superheat / subcooling, and provide a 4-20 mA signal output, as manufactured by Hansen Technologies Corporation or approved equal."

HANSEN

Hansen Technologies Corporation
6827 High Grove Boulevard
Burr Ridge, Illinois 60527 USA
Tel: 630.325.1565 Fax: 630.325.1572 Toll: 800.426.7368
Email: info@hantech.com Web: www.hantech.com
USA · Asia · Europe · India · Latin America · Middle East
© 2006 Hansen Technologies Corporation