



Sealed Motor Valve: HMV 1 1/4"

Specifications, Applications,
Service Instructions & Parts

SEALED
MOTOR
VALVE

Motor Operated Valve
for Refrigerants
and other
Hansen Approved Fluids

INTRODUCTION

The Hansen Sealed Motor Valve (HMV) is a unique motor operated valve which eliminates the most common concern of other motor operated valves, valve stem seal leakage. The HMV has no valve stem seal because the motor's non-electric rotor is enclosed in a stainless steel can which contains the fluid pressure. The motor's electric stator is outside the stainless steel can, isolated from the fluid in the valve. Typical applications include a slow opening solenoid valve, a temperature controlled evaporator regulator, or a gravity drain valve. Patents are pending.

APPLICATIONS

The Hansen Sealed Motor Valve (HMV) is ideal for applications where external leakage is intolerable. The HMV is suitable for use with a variety of fluids, including those that are incompatible with copper, such as ammonia, because the motor stator's copper windings are isolated from the fluid in the valve.

The HMV is slow opening and closing (about 15 to 30 seconds depending on valve size), which minimizes the potential for liquid velocity shock or "water hammer" often experienced with quick opening and closing solenoid valves.

The HMV requires no pressure drop to operate, unlike most pressure regulators and solenoid valves which require a minimum 2 psi pressure drop to keep the valve fully open. Therefore, the HMV can be used for applications which require a very low pressure drop (e.g. suction lines), or no pressure drop (e.g. equalizing or drain lines).

KEY FEATURES

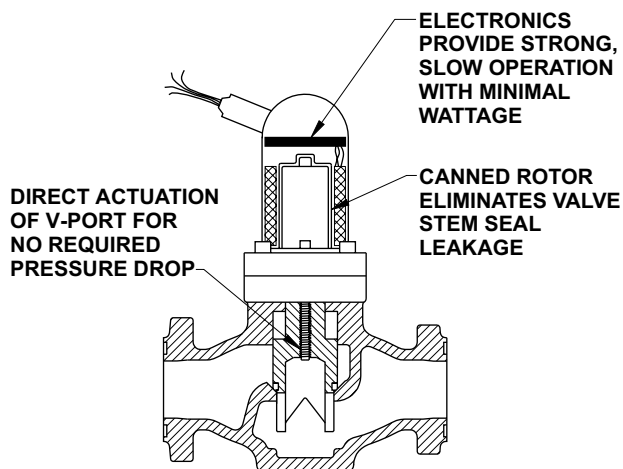

ADDITIONAL FEATURES

- Tight closing Teflon seat.
- Controlled opening and closing minimizes liquid velocity shock, "water hammer."
- All moving parts are sealed so that frost will not affect operation.
- Motor is more compact and lightweight than other motor operated valves.
- Same flanges and spacing as Hansen HA4A/HS4A pressure regulators and solenoid valves.
- Suitable for use with ammonia, R22, R134a, glycol, water, brines, and other Hansen approved fluids.

MATERIAL SPECIFICATIONS

Mechanical

Body: ductile iron, ASTM A536

Bonnet Plate: steel, zinc plated with yellow chromate

V-port Seat: Teflon

Rotor Can: stainless steel

Rotor Can O-ring: neoprene

Stator Housing: stainless steel

Safe Working Pressure: 400 psig (27 bar)

Operating Temperature: -60°F to +240°F (-50°C to +115°C)

Electrical

Power: 28 VDC, 75 W peak, 10 W average

Enclosure: watertight, NEMA 4X

Cable: 5 wire, 18 AWG, length 10 feet (3 m)

OPERATION

The motor shaft is coupled to a threaded stem which directly drives the valve v-port open or closed. The motor is a brushless DC servo-motor which operates on 28 VDC. Electronics inside the stator housing pulse power to the motor to provide strong, slow operation with minimal wattage.

The valve is electrically operated by five wires. Two provide 28 VDC power, and a third is ground. The other two wires are control signal wires; they command the valve to either open or close. Electrically connecting the open wire to 28 VDC common will drive the valve open. Electrically connecting the close wire to 28 VDC common will drive the valve closed. If neither open or close wire is electrically connected to 28 VDC common, the valve will remain at its last position. (Also, on loss of power the valve will remain at its last position.)

The locked rotor amperage is not significantly higher than the running amperage; therefore, continuing to supply power to the motor after it has fully opened or closed is acceptable and typical for the HMV valve. The power supply and wiring must be sized for a 75 W peak pulsed load. However, average power consumed is 10 W. Since the motor consumes minimal wattage, electrical costs and overheating are not concerns.

CAPACITIES

SUCTION VAPOR CAPACITIES, TONS AMMONIA

Evap. Temp. °F	Pressure Drop (psi)	Nominal Size				
		¾"	1"	1¼"	1½"	2"
40	0.25	4.4	8.0	11	24	32
	0.50	6.2	11	16	34	45
	1.0	8.7	16	22	48	64
	2.0	12	22	31	67	90
0	0.25	2.8	5.1	7.1	15	20
	0.50	3.9	7.1	10	21	29
	1.0	5.5	10	14	30	40
	2.0	7.6	14	20	42	56
-40	0.25	1.9	3.4	4.7	10	14
	0.50	2.6	4.7	6.6	14	19
	1.0	3.6	6.5	9.2	20	26
	2.0	4.8	8.8	12	26	36
Cv		6.4	11.7	16.4	35	47

Capacities assume 86°F condensing, except -40°F assumes +20°F liquid (e.g. two stage). For overfeed evaporator suction, add 20% to the evaporator load or use next larger size to accommodate liquid volume.

HOT GAS DEFROST CAPACITIES, TONS AMMONIA

Nominal Size				
¾"	1"	1¼"	1½"	2"
9 to 15	15 to 28	28 to 39	39 to 73	73 to 106

Evaporator tons at 10°F temperature differential, valve capacities are conservative.

HIGH PRESSURE LIQUID CAPACITIES, TONS AMMONIA

Pressure Drop (psi)	Nominal Size				
	¾"	1"	1¼"	1½"	2"
2	139	255	357	762	1023
3	171	312	437	933	1253
5	220	403	564	1205	1618

Capacities assume +86°F liquid, +20°F evaporator, and no flashing through the valve.

WIRING CUSTOMER SUPPLIED POWER SUPPLY AND CONTROLLER

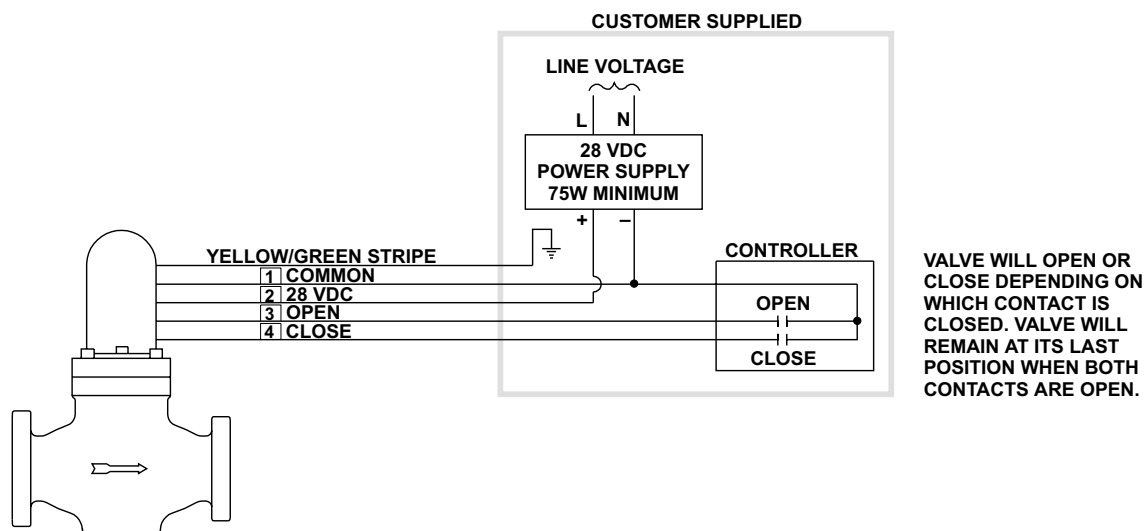

TYPICAL APPLICATIONS

MODULATING: ROOM TEMPERATURE CONTROL

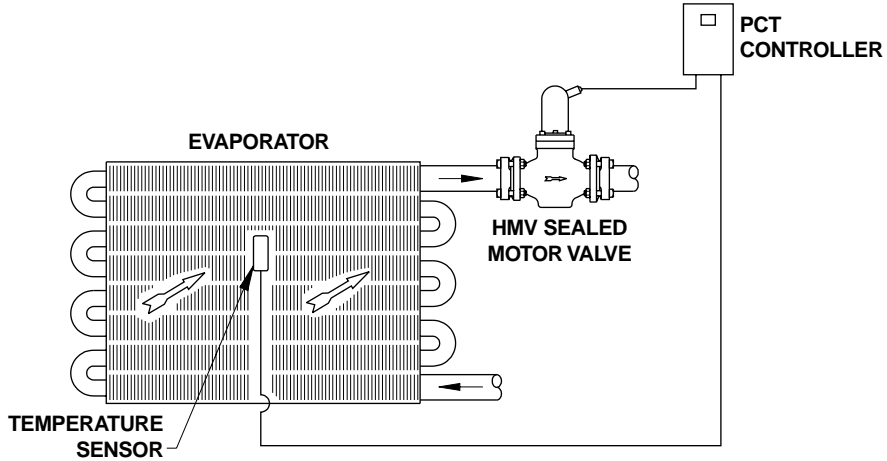

SLOW OPENING AND CLOSING: SUCTION STOP VALVE

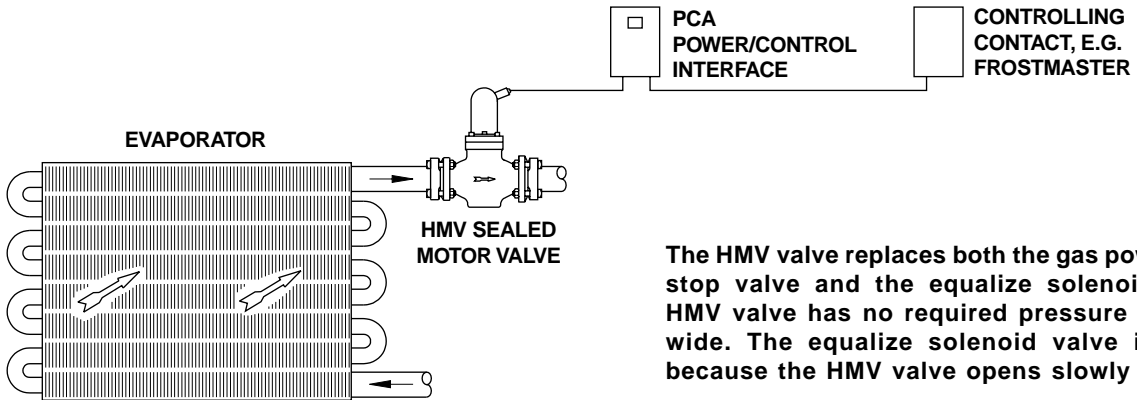

NO PRESSURE DROP: GRAVITY DRAIN

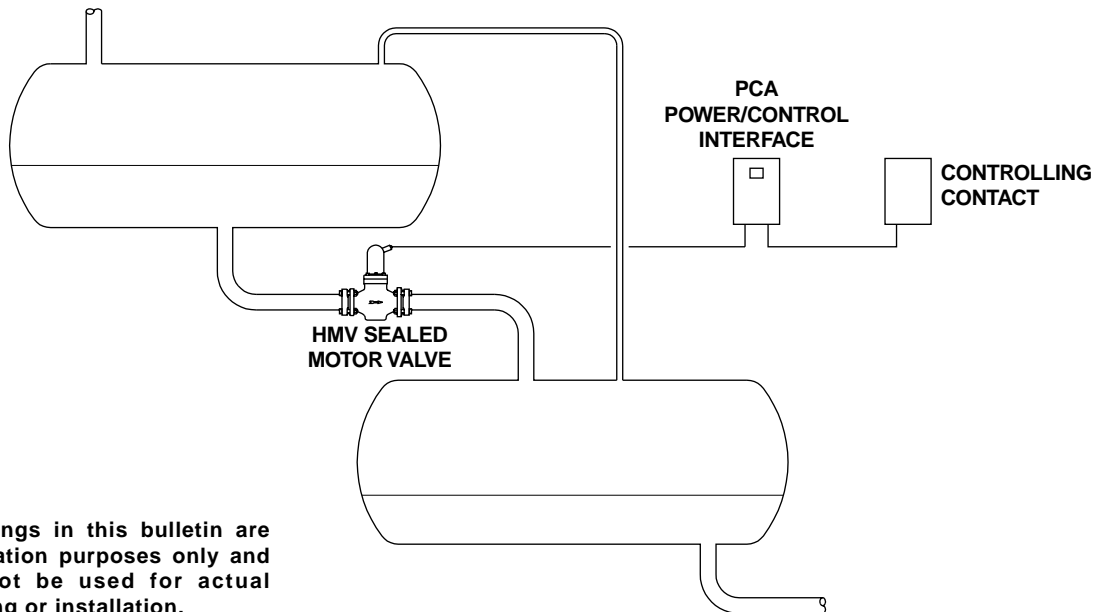

The drawings in this bulletin are for illustration purposes only and should not be used for actual engineering or installation.

**INSTALLATION DIMENSIONS, INCH (MM)
3/4" THROUGH 1 1/4" SEALED MOTOR VALVE**

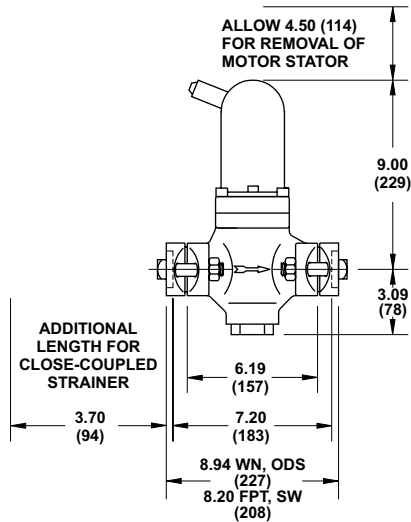

1 1/2" THROUGH 2" SEALED MOTOR VALVE

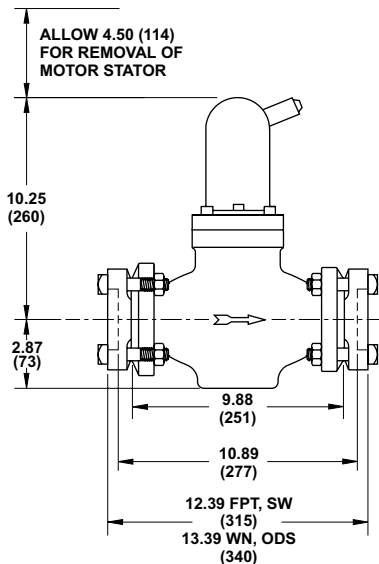

STRAINER CANNOT BE CLOSE-COUPLED

CAUTION

Hansen valves are for refrigeration systems only. These instructions and related safety precautions must be read completely and understood before selecting, using, or servicing these valves. Only knowledgeable, trained refrigeration technicians should install, operate, or service these valves. Stated temperature and pressure limits should not be exceeded. Bonnets should not be removed from these valves unless the system has been evacuated to zero pressure. See also Safety Precautions in current List Price Bulletin and Safety Precautions Sheet supplied with product. Escaping refrigerant can cause injury, especially to the eyes and lungs.

WARRANTY

Hansen electrical and electronic parts are guaranteed against defective materials and workmanship for 90 days F.O.B. our plant. All other components are guaranteed for one year F.O.B. our plant. No consequential damages or field labor is included.

**ORDERING INFORMATION,
HMV SEALED MOTOR VALVE**

Nominal Size inch (mm)	Flange Connection Styles and Sizes		
	FPT, SW, WN		ODS
	Standard	Also	Standard
3/4 (20)	3/4	1, 1 1/4	7/8
1 (25)	1	3/4, 1 1/4	1 1/8
1 1/4 (32)	1 1/4	3/4, 1	1 3/8
1 1/2 (40)	1 1/2	2	1 5/8
2 (50)	2	1 1/2	2 1/8

TO ORDER: Specify valve type HMV, nominal size, connection style and size, and optional strainer if required.

OPTIONAL CONTROLS

Catalog Number	Description
PCA	Power/Control Interface for open/close applications
PCB	Power/Control Interface for modulating applications
PCT	Power Supply/Modulating Controller for temperature control* (includes sensor)

*For liquid level control, contact factory.

TYPICAL SPECIFICATIONS

Motor operated control valves shall feature direct actuation of the main valve seat by the motor shaft, a canned motor to eliminate valve stem seal leakage, a ductile iron body, and be suitable for a safe working pressure of 400 psig (27 bar), as manufactured by Hansen Technologies Corporation, or approved equal.

HANSEN TECHNOLOGIES CORPORATION

6827 High Grove Boulevard
Burr Ridge, Illinois 60521 U.S.A.
Telephone: 630-325-1565
Toll-free: 800-426-7368
FAX: 630-325-1572
E-mail: info@hantech.com
Web Site: www.hantech.com