

## HANSEN TECHNOLOGIES CORPORATION

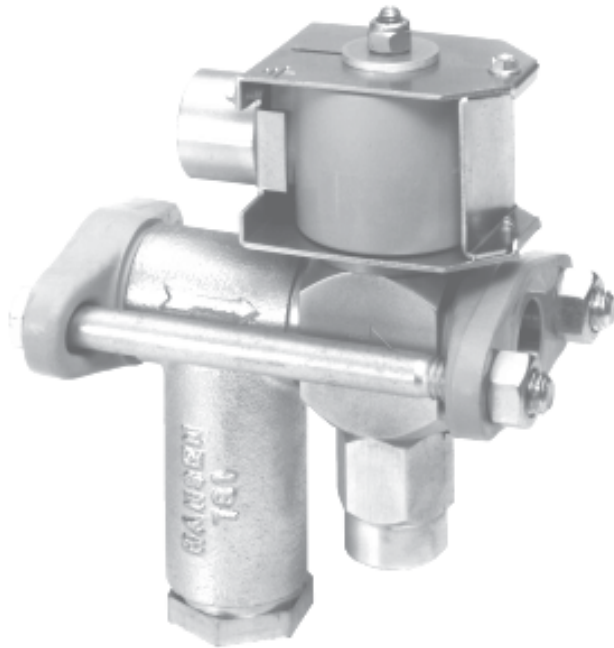

HS6 Solenoid Valve

### INTRODUCTION

This flanged, industrial refrigeration duty solenoid valve is very simple and compact but rugged in construction. Body is plated steel alloy while direct lifting stainless steel plunger contains teflon seat which closes upon stainless steel orifice. When electrically energized, seat opens wide; when de-energized, it closes to stop flow in the arrow direction on the valve body.

### APPLICATIONS

This small, direct lifting valve is used primarily as a pilot for various larger gas-powered or liquid powered main valves, as a remote pilot for back pressure regulators or other devices, or as a liquid stop valve for expansion valves, float valves, or as a general purpose pilot line for ammonia, R22, R134a, and other approved refrigerants or oil.

### MAXIMUM RATINGS, AMMONIA

Liquid, Receiver Pressure: 15 Tons  
Flow Factor: Cv = 0.41

## Specifications, Applications, Service Instructions & Parts

### HS6 SOLENOID VALVE 5/32" (4mm) PORT

Flanged  
1/4" thru 1/2"  
FPT, SW, WN, ODS  
for refrigerants

### KEY FEATURES

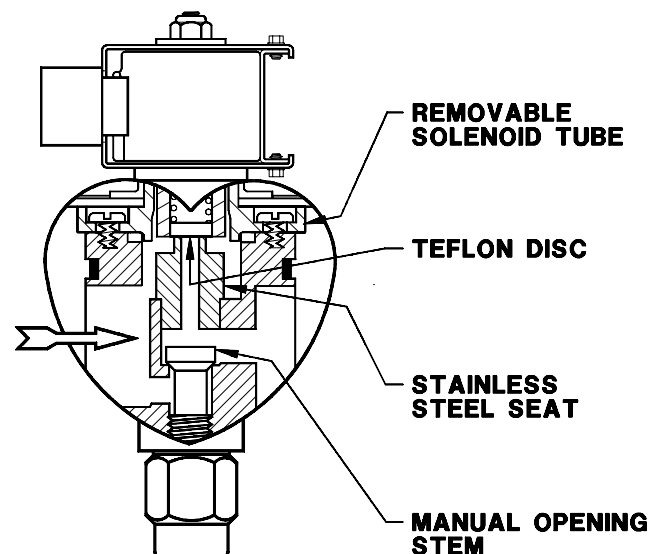

### ADDITIONAL FEATURES

Dimensionally Interchanges with R/S S6N  
Molded Hansen standard coil  
300 PSI (20 bar) MOPD  
Available close-coupled strainer  
Heavy-duty, direct lift  
CSA Certified  
Non-asbestos gaskets

## MATERIAL SPECIFICATIONS

Body: Steel, plated  
 Solenoid Tube: Stainless steel  
 Plunger: Stainless steel  
 Seat Orifice: Stainless steel  
 Seat: Teflon  
 Safe Working Pressure: 400 PSIG (27 bar)  
 Operating Temperature: -60F to 240F (-50 to 115°C)

## ADVANTAGES

Power saving, low-wattage molded coil; teflon seat; stainless steel trim; spring-closing; double-seal manual opening stem; replaces R/S S6N. One standard molded coil fits all Hansen valves.

## INSTALLATION

Match arrow on body with system flow direction. Protect interior of valve from dirt during installation; normally use close-coupled inlet strainer. Allow 2" (50mm) above valve for coil removal, 1" (25mm) below for seal cap removal, and 3" (76mm) below strainer for screen removal. If a pressure reversal can occur, as during hot gas defrost with liquid recirculation, use a check valve on the outlet side of the HS6.

## INSTALLATION DIMENSIONS

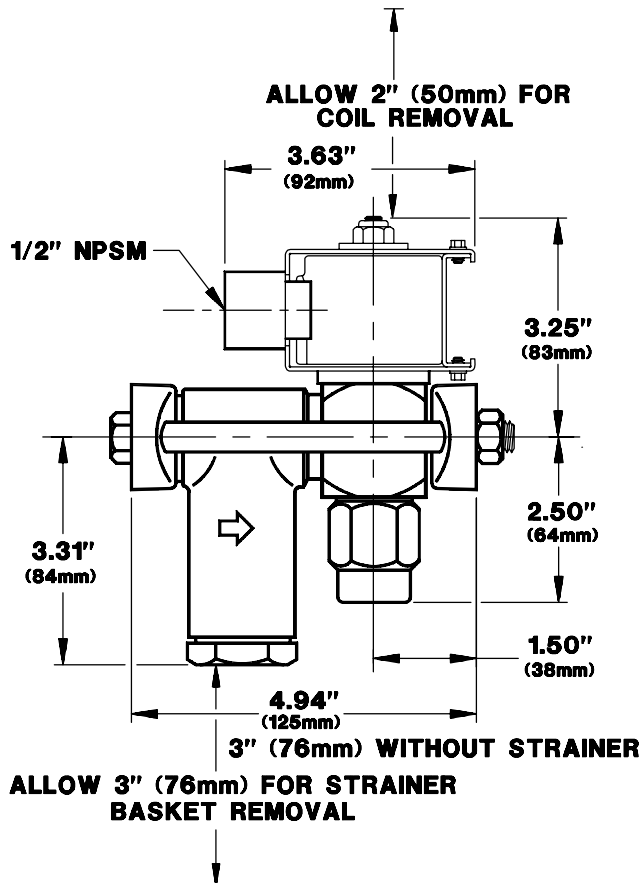

## ELECTRICAL

The coil draws 16 watts and will operate properly between 85% and 110% of rated voltage (24V coil draws 19 watts). Standard coil connection is a 1/2" fitting (NPSM) for conduit, with 18" pigtail leads. Coils with DIN plug or junction box are available; contact factory. All coils have a standard zinc plated, steel housing which meets NEMA 3R (rain-proof) and NEMA 4 (splashproof, approx. IP65) requirements; junction box is considered NEMA 1. Coil should only be energized while on solenoid tube; otherwise immediate coil burnout may occur. To avoid bending the solenoid tube, remove coil from valve before connecting any electrical conduit.

Lighting is available.

ITEM	DESCRIPTION	QTY	PART NO
	<b>Coil Kit (115V) 1/2" Fitting</b>		<b>70-1057</b>
	<b>Coil Kit (208/230V) 1/2" Fitting</b>		<b>70-1056</b>
	<b>Coil Kit (24V) 1/2" Fitting</b>		<b>70-1058</b>
	<b>Coil Kit (Other Voltages)</b>		<b>FACTORY</b>
	Above Kits Consist of:		
1a	Bare Coil, 115V 50/60Hz, wire leads	1	70-0271
1b	Bare Coil, 208/230V 50/60Hz, wire leads	1	70-0286
1c	Bare Coil, 24V 50/60Hz, wire leads	1	70-0284
1d	Other Voltage Coils	1	FACTORY
2	Coil Housing Assembly Kit	1	70-1060
3	Coil Washer	1	70-0289
4	Coil Nut	1	70-0281
	<b>Solenoid Tube/Plunger Kit *</b>		<b>70-1059</b>
	Above Kit Consists of:		
5	Plunger	1	70-0295
6	Solenoid Tube	1	70-0298
7	Solenoid Tube Gasket	1	70-0301
8	Tube Screws	4	70-0297
3	Coil Washer	1	70-0289
4	Coil Nut	1	70-0281
	<b>Gasket Kit Consists of:</b>		<b>70-1011</b>
7	Solenoid Tube Gasket	1	70-0301
9	Flange Gasket	3	70-0065
10	Stem O-ring	1	70-0010
11	Stem Washer	1	70-0026
12	Stem Packing	1	70-0025
13	Packing Nut	1	70-0019
14	Pin	1	70-0150
15	Seal Cap Gasket	1	70-0008
16	<b>Assembled Body Replacement Kit</b> Complete Valve less Coil Kit		<b>70-1012</b>
	<b>Seal Cap Kit Consists of:</b>		<b>70-1004</b>
17	Seal Cap	1	70-0007
15	Seal Cap Gasket	1	70-0008
	<b>Strainer Screen Kit Consists of:</b>		<b>78-1001</b>
18	Screen Assembly	1	78-0005
19	Strainer Cap Gasket	1	78-0016
	<b>Bolt and Nut Kit</b>		
	For HS6 less Strainer (a)		70-1006
	For HS6 with Strainer (b)		70-1007
	Consists of:		
21	Flange Nut (7/16" - 14)	2	70-0055
22a	Flange Bolt (less strainer) 3.75"	2	70-0073
22b	Flange Bolt (with strainer) 5.5"	2	70-0076
20	Strainer Cap	1	78-0002
23	<b>Assembled Strainer Replacement Kit</b>		<b>78-1002</b>
24	<b>Flange Kit (FPT,SW,WN,ODS)</b> Includes (2) Flanges only. Specify Style and Size		<b>FACTORY</b>

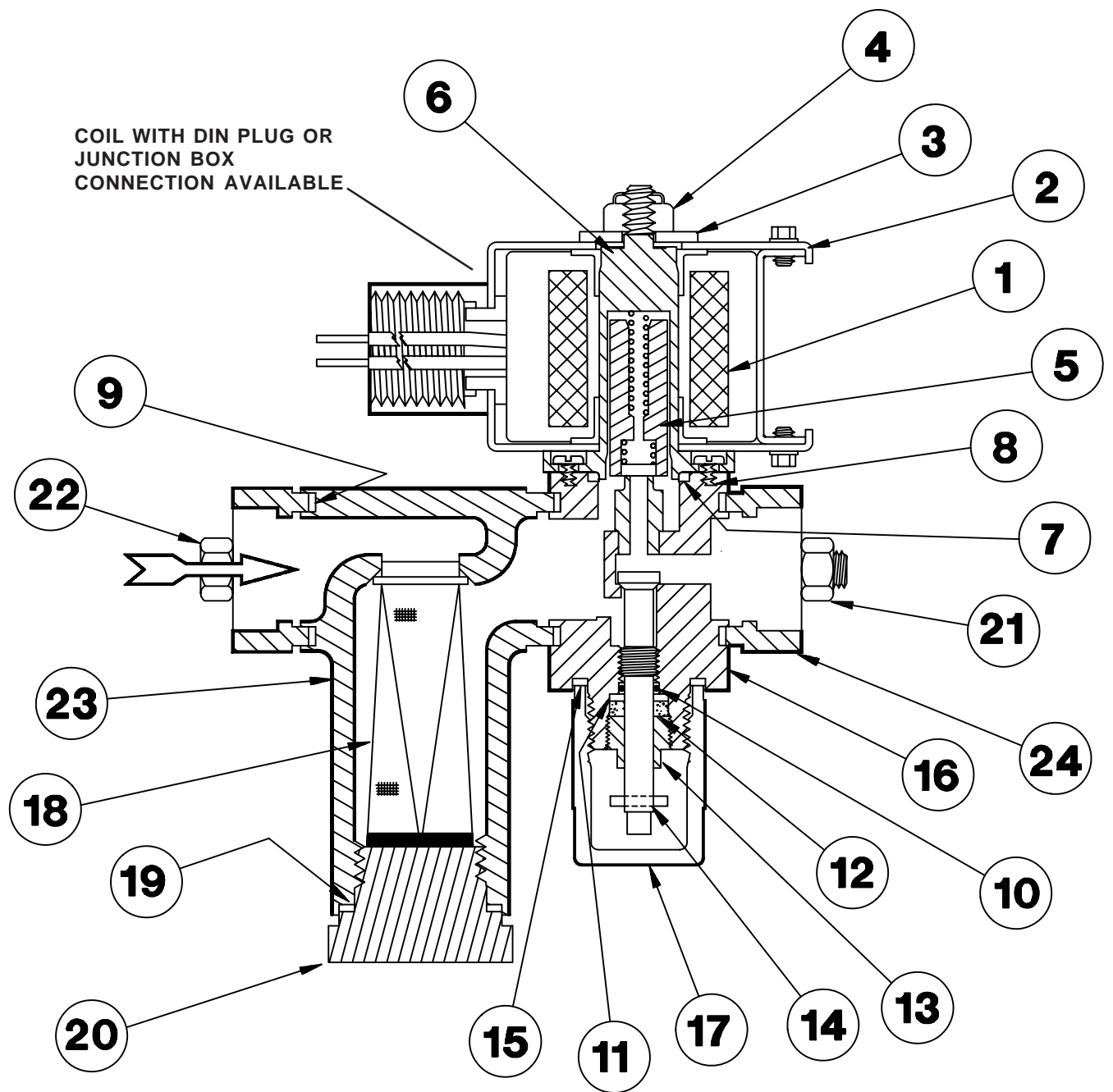

\* Beginning in 1993, a new interchangeable, threaded top, solenoid tube as shown in this bulletin, will be used on all solenoid valves. See Hansen Coil Bulletin SC1 for more details.

## SERVICE AND MAINTENANCE

**Failure to open:** wrong voltage coil; low line voltage; controlling switch or thermostat not contacting; coil is burned-out; inlet/outlet pressure differential too high; plunger is jammed closed with dirt.

**Failure to close:** controlling switch or thermostat not opening contacts; manual opening stem is turned in; dirt under seat; eroded seat parts; plunger is jammed upward by dirt.

Before opening the valve for service, be sure it is isolated from the system and all refrigerant is removed. Disconnect electrical power from coil. Remove the coil by unscrewing the coil nut and removing the washer. Loosen the four solenoid tube screws, proceeding cautiously to avoid any refrigerant still remaining inside the valve. Remove tube screws and pry off the solenoid tube from the body.

Check face of teflon seat in plunger, plunger spring, and seat orifice in body. Clean, polish or replace parts as necessary. The seat orifice is integral with the body. Install new solenoid tube gasket and oil lightly. Reassemble tube to body with four screws. Carefully check the valve for leaks before restoring to service.

## CAUTION

Hansen valves are only for refrigeration systems. These instructions must be completely read and understood before selecting, using or servicing Hansen valves. Only knowledgeable, trained refrigeration mechanics should install, operate, or service these valves. Stated temperature and pressure limits should not be exceeded. Solenoid tubes should not be removed from valves unless system has been evacuated to zero pressure. Must also see Safety Precautions in current List Price Bulletin and Safety Precautions Sheet supplied with product.

## WARRANTY

Hansen valves are guaranteed against defective materials or workmanship for one year F.O.B. factory. No consequential damages or field labor is included.

## ORDERING INFORMATION, HS6 SOLENOID VALVE

FLANGE CONNECTION STYLE & SIZES		
FPT, SW, WN		ODS
STD	ALSO	STD
1/2"	1/4", 3/8"	5/8"

FPT: Female Pipe Thread (American National Standard)  
SW: Socket Weld to accommodate American and API pipe  
WN: Weld Neck to match American Schedule 40 pipe  
ODS: Outside Diameter Sweat, for copper tube size

Standard molded solenoid coil is included for 50/60Hz 208/230, 115, or 24 volts; other voltages offered. Standard coil connection is a 1/2" fitting (NPSM). Coils with DIN plug or junction box are available; contact factory. Pilot lights are also available.

**TO ORDER:** Specify type, connection style and size, volts, and strainer if required. Unless otherwise specified, standard coil with 1/2" fitting will be supplied.

## TYPICAL SPECIFICATIONS

"Refrigerant solenoid valves shall have molded, watertight coils, teflon seats, steel or ductile iron bodies, spring closing pilot and main valve seats, and be suitable for a safe working pressure of 400 PSIG, as manufactured by Hansen Technologies Corporation or approved equal."

## OTHER PRODUCTS

Gauge, Purge, and Needle Valves: 1/4"  
Threaded Shut-off Valves: 3/8" to 1 1/4"  
Socket Weld Shut-off Valves: 1/2" to 2 1/2"  
Welding Steel Shut-off Valves: 2" to 14"  
Expansion Valves (Regulators): 3/8" to 4"  
Refrigerant Solenoid Valves  
Pressure Regulators  
Refrigerant Check Valves  
Gas-Powered Valves  
Refrigerant Float Switches  
Float Regulators (High Side)  
Refrigerant Liquid Pumps  
Vari-Level® Adjustable Level Controls  
Techni-Level® Transducer Probes  
AUTO-PURGERS®  
Frost Master® Defrost Controllers

## HANSEN TECHNOLOGIES CORPORATION

6827 High Grove Boulevard  
Burr Ridge, Illinois 60527 U.S.A.  
Telephone: (708) 325-1565  
Toll-free: 1-800-426-7368  
FAX: (708) 325-1572