



HS6 Solenoid Valve
with Close-Coupled ST050 Strainer

INTRODUCTION

This flanged, industrial refrigeration duty solenoid valve is very simple and compact but rugged in construction. Body is plated steel alloy with a direct lifting stainless steel plunger that contains a teflon seat that closes on a stainless steel orifice. When electrically energized, seat opens wide; when de-energized, it closes to stop flow in the arrow direction on the valve body.

APPLICATIONS

This small, direct lifting valve is used primarily as a pilot for various larger gas-powered or liquid powered main valves, as a remote pilot for back pressure regulators or other devices, or as a liquid stop valve for expansion valves, float valves, or as a general purpose pilot line for ammonia, R22, R134a, CO2 and other approved refrigerants or oil.

MAXIMUM RATINGS, AMMONIA

Liquid, Receiver Pressure: 15 Tons (52 kW)
Flow Factor: $C_v=0.41$ ($K_v=0.35$)

ADDITIONAL FEATURES

Dimensionally Interchanges with R/S S6N
Encapsulated Hansen standard coil
300 psi (20 bar) MOPD
Available close-coupled strainer
Heavy-duty, direct lift
CSA Certified
Non-asbestos gaskets

Specifications, Applications, Service Instructions & Parts

**HS6
SOLENOID VALVE
5/32" (4 mm) PORT**

**Flanged
1/4" thru 3/4"
(7 mm thru 20 mm)
for refrigerants**

KEY FEATURES

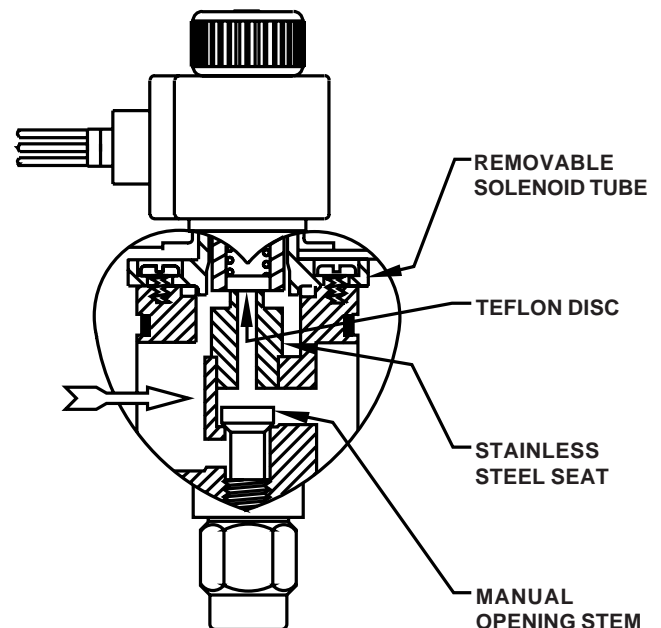

MATERIAL SPECIFICATIONS

Body: Steel, plated

Solenoid Tube: Stainless steel

Plunger: Stainless steel

Seat Orifice: Stainless steel

Seat: Teflon

Safe Working Pressure: 400 psig (27 bar),
600 psig (40 bar) available for CO2

Operating Temperature: -60°F to 240°F
(-50°C to 115°C)

ADVANTAGES

Power saving, low-wattage encapsulated coil; teflon seat; stainless steel trim; spring-closing; double-seal manual opening stem; replaces R/S S6N. One standard encapsulated coil fits all Hansen valves.

INSTALLATION

Match arrow on body with system flow direction. Protect interior of valve from dirt during installation; normally use close-coupled inlet strainer. Allow 2.25" (57 mm) above valve for coil removal, 1" (25 mm) below for seal cap removal, and 3" (76 mm) below strainer for screen removal. If a pressure reversal can occur, as during hot gas defrost with liquid recirculation, use a check valve on the outlet side of the HS6.

ELECTRICAL

The coil draws 16 watts and will operate properly between 85% and 110% of rated voltage (24V coil draws 19 watts). Standard coil connection is a 1/2" fitting (NPSM) for conduit, with two 18" wire leads and ground wire. Coils with DIN plug or 1/2" NPSM quick disconnect plug are available. Contact the factory. All coils are totally encapsulated and meet NEMA 3R (rainproof) and NEMA 4 (splashproof, approx. IP65) requirements. The coil should only be energized while on the solenoid tube. Otherwise, immediate coil burnout may occur. To avoid bending the solenoid tube, remove the coil from valve before connecting any electrical conduit. Pilot lights are available.

INSTALLATION DIMENSIONS

INCHES (MILLIMETERS)

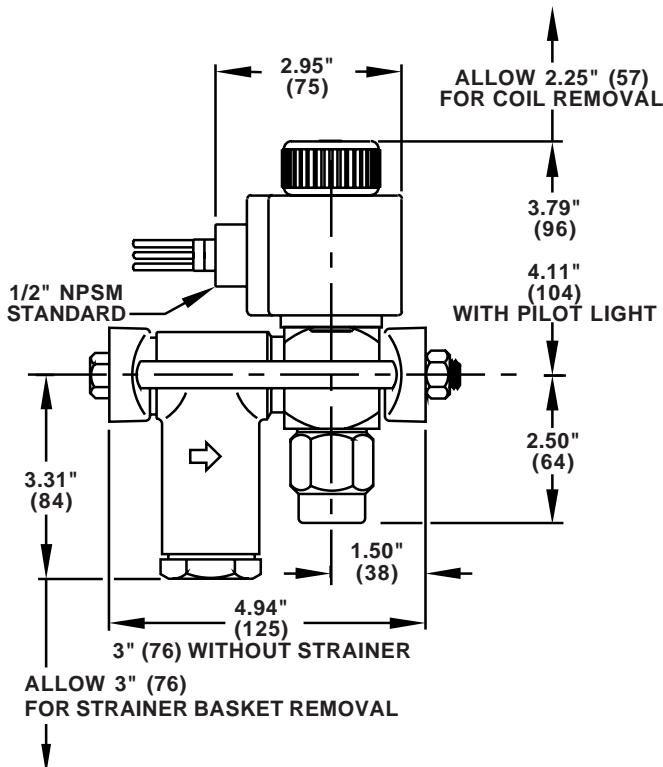

PARTS LIST

ITEM	DESCRIPTION	QTY	PART NO.
	Coil Kit (115V) 1/2" Fitting w/leads	1	70-1085
	Coil Kit (208/230V) 1/2" Fitting w/leads	1	70-1086
	Coil Kit (24V) 1/2" Fitting w/leads	1	70-1087
	Coil Kit (Other Voltages)	1	FACTORY
	<i>Above kits consist of:</i>		
1a	Bare Coil, 115V 50/60 Hz w/leads	1	70-0580
1b	Bare Coil, 208/230V 50/60Hz w/leads	1	70-0581
1c	Bare Coil, 24V 50/60Hz w/leads	1	70-0582
1d	Other Voltage Coils	1	FACTORY
3	Coil Knob	1	70-0579
	Solenoid Tube/Plunger Kit	1	70-1059
	<i>Above kit consists of:</i>		
5	Solenoid Tube	1	70-0298
4	Plunger	1	70-0295
6	Solenoid Tube Gasket	1	70-0301
2	O-Ring	1	75-0340
7	Screws (4)	4	70-0297
	Gasket Kit	1	70-1011
	<i>Above kit consists of:</i>		
6	Solenoid Tube Gasket	1	70-0301
8	Flange Gasket	1	70-0065
9	Stem O-Ring	1	70-0010
10	Stem Washer	1	70-0026
11	Stem Packing	1	70-0025
12	Packing Nut	1	70-0019
13	Pin	1	70-0150
14	Seal Cap Gasket	1	70-0008
15	Assembled Body Replacement Kit	1	70-1012
	<i>Complete Valve less Coil Kit</i>		
	Seal Cap Kit	1	70-1004
	<i>Above kit consists of:</i>		
16	Seal Cap	1	70-0007
14	Seal Cap Gasket	1	70-0008
	Strainer Screen Kit	1	78-1001
	<i>Above kit consists of:</i>		
17	Screen Assembly	1	78-0005
18	Strainer Cap Gasket	1	78-0016
	Bolt and Nut Kit for HS6 less Strainer	1	70-1006
	Bolt and Nut Kit for HS6 with Strainer	1	70-1007
	<i>Above kits consist of:</i>		
20	Flange Nut (7/16" - 14")	2	70-0055
21a	Flange Bolt (less strainer) 3.75"	2	70-0073
21b	Flange Bolt (with strainer) 5.5"	2	70-0076
19	Strainer Cap	1	78-0002
22	Assembled Strainer Replacement Kit	1	78-1002
23	Flange Kit (FPT, SW, WN, ODS)		FACTORY
	<i>Includes (2) flanges only. Specify style/size.</i>		

COIL WITH DIN PLUG OR 1/2" NPSM QUICK
DISCONNECT PLUG CONNECTION AVAILABLE

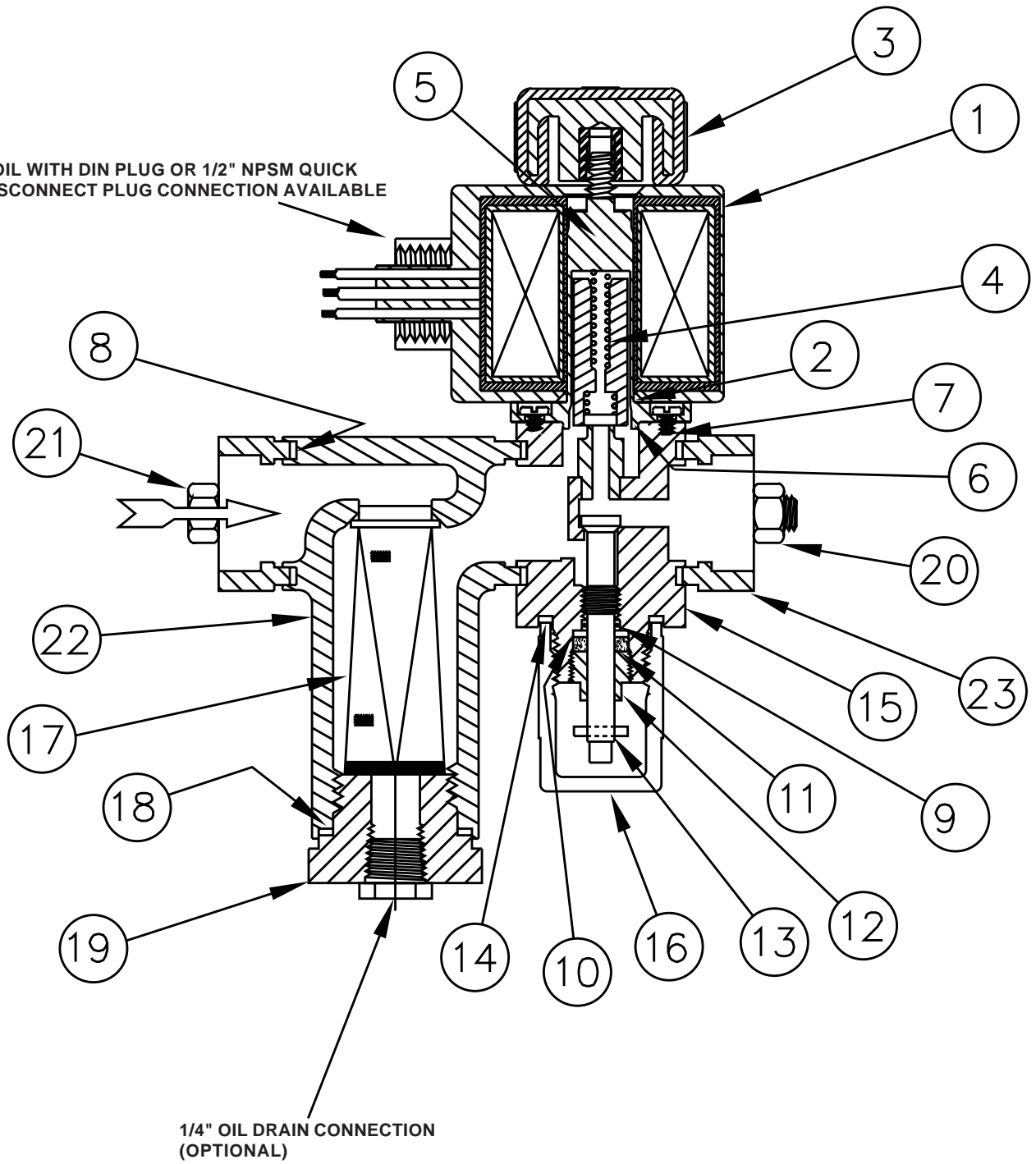

SERVICE AND MAINTENANCE

Failure to open: Wrong voltage coil; low line voltage; controlling switch or thermostat not contacting; coil is burned-out; inlet/outlet pressure differential too high; plunger is jammed closed with dirt.

Failure to close: Controlling switch or thermostat not opening contacts; manual opening stem is turned in; dirt under seat; eroded seat parts; plunger is jammed upward by dirt.

Before opening the valve for service, be sure it is isolated from the system and all refrigerant is removed. Disconnect electrical power from coil. Remove the coil by unscrewing the coil knob. Loosen the four solenoid tube screws and break gasket seal, proceeding cautiously to avoid any refrigerant still remaining inside the valve. Remove the tube screws to separate the solenoid tube from the body.

Check face of teflon seat in plunger, plunger spring, and seat orifice in body. Clean, polish or replace parts as necessary. Always replace the solenoid tube when replacing the plunger. These are wear parts and must be inspected as part of a routine maintenance program. The seat orifice is integral with the body. Install new solenoid tube gasket and oil lightly. Reassemble tube to body with four screws. Factory torque is 2 ft-lbs (2.8 Nm). Carefully check the valve for leaks before restoring to service.

CAUTION

Hansen valves are for refrigeration systems only. These instructions must be completely read and understood before selecting, using or servicing valves. Only knowledgeable, trained refrigeration mechanics should install, operate, or service these valves. Stated temperature and pressure limits should not be exceeded. Solenoid tubes should not be removed from valves unless system has been evacuated to zero pressure. See also the Safety Precautions in the current List Price and the Safety Precautions Sheet supplied with product. Escaping refrigerant might cause personal injury, particularly to the eyes and lungs.

WARRANTY

Hansen valves are guaranteed against defective materials or workmanship for one year FOB factory. No consequential damages or field labor is included.

ORDERING INFORMATION, HS6 SOLENOID VALVE

FLANGE CONNECTION STYLE & SIZES INCHES (MILLIMETERS)		
FPT, SW, WN		ODS
STD	ALSO	STD
1/2" (15)	1/4" (7) 3/8" (10) 3/4" (20)	5/8" (16)

FPT: Female Pipe Thread (American National Standard)
SW: Socket Weld to accommodate American and API pipe
WN: Weld Neck to match American Schedule 40 pipe
ODS: Outside Diameter Sweat, for copper tube size

Standard encapsulated solenoid coil is included for 50/60Hz 208/230, 115, or 24 volts; other voltages offered. Standard coil connection is a 1/2" fitting (NPSM). Coils with DIN plug or 1/2" NPSM quick disconnect plug are available; specify when ordering. Pilot lights are also available.

OPTIONAL BEACON PILOT LIGHTS

Pilot Light Kit includes Beacon pilot light, knob and o-ring. A/ C Coils Only.

PILOT LIGHT KIT	
COLOR	PART NO.
Red	70-1100
Amber	70-1101
Green	70-1102



TO ORDER:

Specify type, connection type and size, volts, and strainer if required. Unless otherwise specified, standard coil with 1/2" connection will be supplied.

TYPICAL SPECIFICATIONS

"Refrigerant solenoid valves shall have encapsulated, watertight coils, Teflon seats, steel or ductile iron bodies, spring closing pilot and main valve seats, and be suitable for a safe working pressure of 400 psig (27 bar), as manufactured by Hansen Technologies Corporation or approved equal."

HANSEN

Hansen Technologies Corporation
6827 High Grove Boulevard
Burr Ridge, Illinois 60527 USA
Tel: 630.325.1565 Fax: 630.325.1572 Toll: 800.426.7368
Email: info@hantech.com Web: www.hantech.com
Asia ■ Europe ■ India ■ Latin America ■ Middle East
© 2005 Hansen Technologies Corporation