



HS7 Solenoid Valve

INTRODUCTION

This flanged, heavy duty, pilot-operated, industrial refrigeration solenoid valve controls the flow of refrigerant. When electrically energized, a slight pressure difference across the valve causes it to open wide; when de-energized, a spring promptly closes the main Teflon seat to stop all flow in the arrow direction on the valve body.

APPLICATIONS

This advanced design valve is ideal as a standard, stock, ammonia liquid line solenoid valve. While primarily for ammonia, this valve is also suitable for R22, R134a, and other approved refrigerants. Most common use is to automatically stop liquid line feed to recirculating liquid overfeed evaporators, to float switch controlled accumulators, and to thermal expansion valves; it is also suitable for hot gas defrost, and evaporator suction. (Note: for gravity liquid drain or equalization applications use low pressure drop HCK2 gas-powered suction stop valve or HS9B gas-powered solenoid valve.)

MAXIMUM RATINGS, AMMONIA*

PORT SIZE	3/4"	1"	1 1/4"
Liquid, Receiver Pressure (Tons)	200	263	400
Recirculation, 4 to 1 (Tons)	45	63	90
Hot Gas, for 0F (Tons)	21	27	40
Suction, 2 PSI Drop at 20F (Tons)	12	16	24
Flow Factor Cv	8.0	10.5	16.3

* For flow near maximum ratings, piping should be one size larger than port.

Specifications, Applications, Service Instructions & Parts

HS7
SOLENOID VALVE
3/4", 1", 1 1/4" PORT
(20, 25, 32 mm)

Flanged
3/4" thru 1 1/4"
FPT, SW, WN, ODS
for Refrigerants

KEY FEATURES

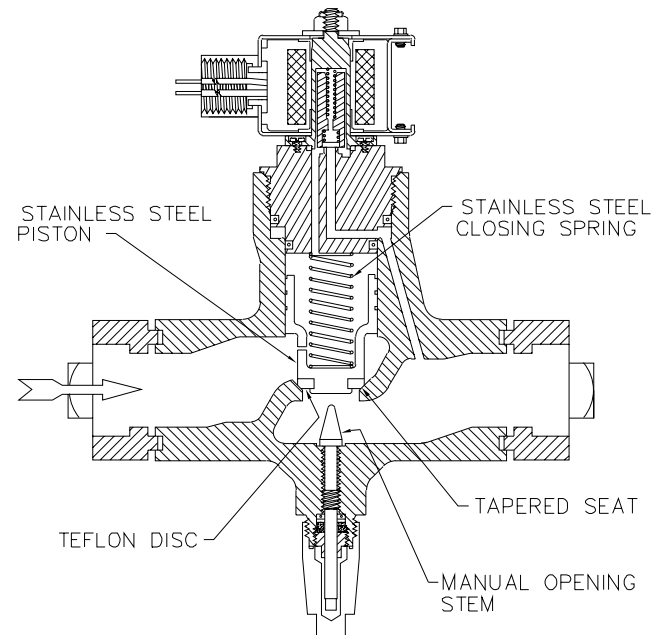

ADDITIONAL FEATURES

- Dimensionally replaces 3/4" or 1" R/S S7A & S4A
- Molded Hansen standard coil
- 300 PSI (20 bar) MOPD
- Teflon main & pilot seats
- Manual opening stem
- Available close-coupled strainer
- Heavy duty, pilot-operation
- Vertical or horizontal installation
- CSA Certified
- Non-asbestos gaskets

MATERIAL SPECIFICATIONS

Body: Ductile iron ASTM A536
 Bonnet-Cartridge: Steel, plated
 Piston: Stainless steel
 Plunger: Stainless steel
 Solenoid Tube: Stainless steel
 Pilot Orifice: Stainless steel
 Seat: Teflon
 Safe Working Pressure: 400 PSIG (27 bar)
 Operating Temperature: -60F to +240F (-50 to +115°C)

ADVANTAGES

Power saving, low-wattage molded coil; Teflon seats; stainless steel trim including piston; spring-closing; double seal manual opening stem; dimensionally replaces ¾" or 1" R/S S7A & S4A. One standard molded coil fits all Hansen valves.

INSTALLATION

Protect interior of valve from dirt during installation; normally use close-coupled inlet strainer. Allow 2" (50 mm) above valve for coil removal, 3" (76 mm) below strainer for screen removal. Match arrow on body with system flow direction. If a pressure reversal can occur, as during hot gas defrost with liquid recirculation, use a check valve on the outlet side of the HS7.

INSTALLATION DIMENSIONS

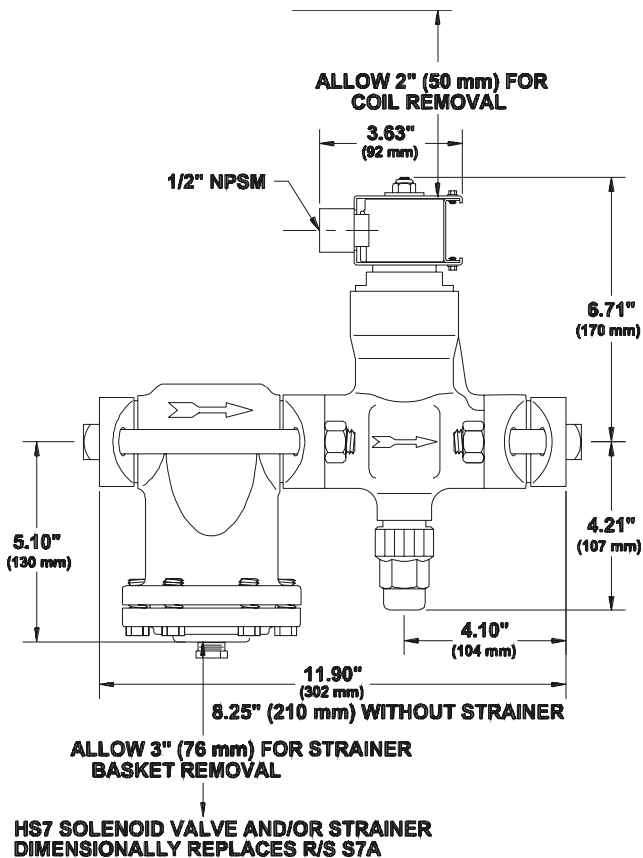

Maximum width of valve is 4.63" (116 mm).

PARTS LIST

ITEM	DESCRIPTION	QTY	PART NO
	Coil Kit (115V) ½" Fitting		70-1057
	Coil Kit (208/230V) ½" Fitting		70-1056
	Coil Kit (24V) ½" Fitting		70-1058
	Coil Kit (Other Voltages)		FACTORY
	Above Kits Consist of:		
1	Bare Coil, 115V 50/60Hz, wire leads	1	70-0271
	Bare Coil, 208/230V 50/60Hz, wire leads	1	70-0286
	Bare Coil, 24V 50/60Hz, wire leads	1	70-0284
	Other Voltage Coils	1	FACTORY
2	Coil Housing Assembly Kit	1	70-1060
3	Coil Washer	1	70-0289
4	Coil Nut	1	70-0281
			70-1059
	Solenoid Tube/Plunger Kit		
	Above Kit Consists of:		
5	Plunger	1	70-0295
6	Solenoid Tube	1	70-0298
7	Solenoid Tube Gasket	1	70-0301
8	Tube Screws	4	70-0297
3	Coil Washer	1	70-0289
4	Coil Nut	1	70-0281
			70-1017
	Gasket Kit		
7	Solenoid Tube Gasket	1	70-0301
9	Upper Body O-ring	1	70-0131
10	Lower Body O-ring	1	70-0130
11	Flange Gasket	3	70-0132
12	Stem O-ring	1	70-0010
13	Stem Washer	1	70-0026
14	Packing Nut	1	70-0019
16	Stem Packing	1	70-0025
15	Seal Cap O-ring	1	70-0011
			70-1018
	Bonnet-Cartridge Kit		
	Above Kit Consists of:		
17	Cartridge Assembly	1	70-0162
	Gasket Kit	1	70-1017
	Solenoid Tube/Plunger Kit	1	70-1059
			70-1019
	Piston Assembly Kit ¾"		
	Piston Assembly Kit 1"		70-1020
	Piston Assembly Kit 1¼"		70-1021
	Above Kits Consist of:		
18	Piston Assembly ¾"	1	70-0166
	Piston Assembly 1"	1	70-0163
	Piston Assembly 1¼"	1	70-0167
19	Closing Spring	1	70-0155
9	Upper Body O-ring	1	70-0131
10	Lower Body O-ring	1	70-0130
			70-1022
	Stem Kit		
20	Stem	1	70-0128
	Gasket Kit	1	70-1017
			70-1023
	Seal Cap Kit		
21	Seal Cap	1	50-0411
15	Seal Cap O-ring	1	70-0011
	Bolt and Nut Kit		
	For HS7 less Strainer (a)		70-1024
	For HS7 with Strainer (b)		70-1025
	Consists of:		
22	Nut	4	70-0136
23	Bolt (less strainer) 3"	4	70-0339
	Bolt (with strainer) 3"	2	70-0339
	Bolt (with strainer) 6.5"	2	70-0134
24	Assembled Body		FACTORY
	Replacement Kit		
	Complete Valve less Coil Kit and Flanges		FACTORY
25	Flange Kit (FPT,SW,WN,ODS)		FACTORY
	Includes (2) Flanges only.		
	Specify Style and Size		

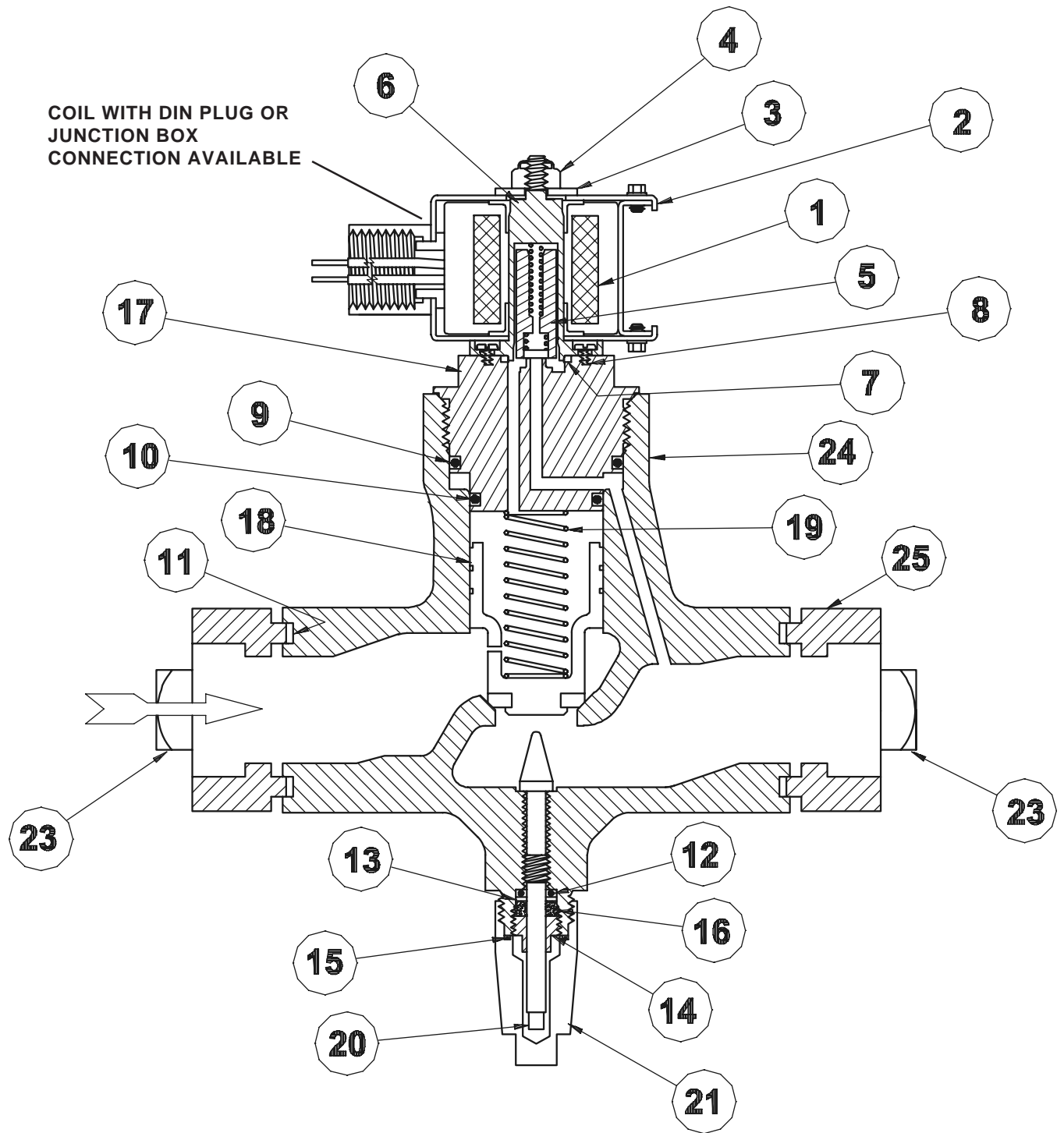

* Beginning in 1993, a new interchangeable, threaded top, solenoid tube as shown in this bulletin, will be used on all solenoid valves. See Hansen Coil Bulletin SC1 for more details.

ELECTRICAL

The coil draws 16 watts and will operate properly between 85% and 110% of rated voltage (24V coil draws 19 watts). Standard coil connection is a 1/2" fitting (NPSM) for conduit, with 18" pigtail leads. Coils with DIN plug or junction box are available; contact factory. All coils have a standard zinc plated, steel housing which meets NEMA 3R (rainproof) and NEMA 4 (splashproof, approx. IP65) requirements; junction box is considered NEMA 1. Coil should only be energized while on solenoid tube; otherwise immediate coil burnout may occur. To avoid bending the solenoid tube, remove coil from valve before connecting any electrical conduit. Pilot lights are available.

SERVICE AND MAINTENANCE

Failure to open: wrong voltage coil; low line voltage; controlling switch or thermostat not contacting; coil is burned-out; inlet/outlet pressure differential too high; less than 2 psi (0.14 bar) pressure drop across valve; piston or plunger is jammed closed with dirt.

Failure to close: controlling switch or thermostat not opening contacts; manual opening stem is turned in; piston or plunger is jammed upward by dirt; damage or dirt at main valve seat or pilot valve seat.

Before opening the valve for service, be sure it is isolated from the system and all refrigerant is removed. Disconnect electrical power from coil. Remove the coil by unscrewing the coil nut and removing the washer. Use a large wrench to unscrew the bonnet-cartridge proceeding cautiously to avoid any refrigerant still remaining inside the valve. Remove closing spring and piston. Check for dirt on piston or seat. Polish with fine emery cloth and replace or else install new parts. Check and replace bonnet-cartridge O-rings if necessary, using refrigerant oil or grease.

To check pilot section of valve, loosen four solenoid tube screws, break seal between solenoid tube and bonnet-cartridge; being careful to avoid any refrigerant which may remain. Check face of Teflon seat in plunger, plunger spring, and pilot seat orifice on bonnet-cartridge. Clean, polish or replace parts as necessary. Pilot seat is integral with bonnet-cartridge. Install new solenoid tube gasket and oil lightly. Reassemble bonnet-cartridge to valve body, using 75 foot-pounds torque to tighten secondary, metal, knife edge seal. Carefully check the valve for leaks before restoring to service.

CAUTION

Hansen valves are only for refrigeration systems. These instructions must be completely read and understood before selecting, using or servicing Hansen valves. Only knowledgeable, trained refrigeration mechanics should install, operate, or service these valves. Stated temperature and pressure limits should not be exceeded. Bonnets, solenoid tubes, etc. should not be removed from valves unless system has been evacuated to zero pressure. Must also see Safety Precautions in current List Price Bulletin and Safety Precautions Sheet supplied with product.

WARRANTY

Hansen valves are guaranteed against defective materials or workmanship for one year F.O.B. factory. No consequential damages or field labor is included.

ORDERING INFORMATION, HS7 SOLENOID VALVE

PORT SIZE (mm)	FLANGE CONNECTION STYLE & SIZES		
	FPT, SW, WN		ODS
	STD	ALSO	STD
3/4" (20)	3/4"	1", 1 1/4"	7/8"
1" (25)	1"	3/4", 1 1/4"	1 1/8"
1 1/4" (32)	1 1/4"	3/4", 1"	1 3/8"

FPT: Female Pipe Thread (American National Standard)
SW: Socket Weld to accommodate American and API pipe
WN: Weld Neck to match American Schedule 40 pipe
ODS: Outside Diameter Sweat, for copper tube size

Standard molded solenoid coil is included for 50/60Hz 208/230, 115, or 24 volts; other voltages offered. Standard coil connection is a 1/2" fitting (NPSM). Coils with DIN plug or junction box are available; contact factory. Pilot lights are available.

TO ORDER: Specify type, connection style and size, volts, and strainer if required. Unless otherwise specified, standard coil with 1/2" fitting will be supplied.

TYPICAL SPECIFICATIONS

"Refrigerant solenoid valves shall have molded, watertight coils, Teflon seats, steel or ductile iron bodies, spring closing pilot and main valve seats, and be suitable for a safe working pressure of 400 psig (27 bar), as manufactured by Hansen Technologies Corporation or approved equal."

HANSEN TECHNOLOGIES CORPORATION

6827 High Grove Boulevard
Burr Ridge, Illinois 60527 U.S.A.
Telephone: (630) 325-1565
Toll-free: 1-800-426-7368
FAX: (630) 325-1572