



Standard Coil with 18" Wire Leads



Plug-in Coil

INTRODUCTION

All Hansen solenoid valves utilize a one-size encapsulated, watertight coil. These coils are strong and efficient, requiring only 16 watts of power. All common voltages and frequencies are available. Coils are designed to operate from 85% to 110% of rated voltage. Pilot light assemblies are also available. The pilot light assemblies require no additional wiring.

APPLICATIONS

The standard coil connection is a 1/2" female straight pipe fitting (NPSM) for conduit, with two 18" long, insulated 18 AWG wire leads plus ground wire. Coils with a DIN plug or a Quick Disconnect plug are available where codes permit.

All coils meet NEMA 3R (IP32) (rainproof) and NEMA 4 (splashproof) requirements. This sealed construction can withstand direct contact with splashing or hose-directed water, wind blown dust or rain, and remain undamaged by the formation of ice.

KEY FEATURES

- One coil fits all valve sizes
- Low wattage
- Encapsulated, watertight design
- Compact size
- Operates on standard voltages
- Combination 50/60Hz coil
- Replaces Danfoss coils using
Coil Adapter Kit 70-1104
- Easily installed, no tools required
- Long life wireless pilot light optional

Specifications, Applications, Service Instructions & Parts

ENCAPSULATED SOLENOID COILS AND BEACON PILOT LIGHTS

with 1/2" Fitting, DIN Plug
or Quick Disconnect Plug

MATERIAL SPECIFICATIONS

Coil: Encapsulated, Class "F" construction

Power: 115V 50/60Hz
208/230V 50/60Hz
24V 50/60Hz
24VDC

Operating Range: 85% to 110% of rated
voltage

Connections: 1/2" fitting (NPSM), standard
DIN plug for socket, optional
QD Plug with NPSM, optional

CSA & CE Approved

ADVANTAGES

Hansen solenoid coils are totally encapsulated. The new design minimizes corrosion and provides a clean finish to the product. The watertight Hansen coils are completely interchangeable with the formerly supplied Danfoss coils provided the proper Coil Adapter Kit is used. See Hansen/Danfoss coil interchangeability drawings on page 3.

Coils have proven reliable for the anticipated broad ranges of electrical conditions and temperatures. All Hansen coils are factory pre-tested to assure reliable operation in the field.

INSTALLATION

To avoid bending the solenoid tube, remove coil from valve before connecting conduit or cable to coil. Make all electrical connections per local and national electrical codes. Place coil onto solenoid tube. Coil may be rotated 360° to facilitate wiring.

To fasten coil to Hansen solenoid tube (threaded top), install o-ring, install coil, install beacon pilot light (optional), and hand tighten knob.

To fasten coil to Danfoss solenoid tube, use Hansen Coil Adapter Kit 70-1104. Remove original Danfoss coil and o-ring and place Hansen coil o-ring and coil onto solenoid tube. Place adapter clip over coil and push down over tube until it snaps in place. Install cap over clip until it snaps into place. The adapter retainer clip can be removed with a blade-type screwdriver.

ELECTRICAL

The coil will draw 16 watts and properly operate between 85% and 110% of rated voltage (the 24 Volt coil will draw 19 watts). Typical power consumption for the standard coils is listed in the table below. In the table, the term "INRUSH AMPS" refers to the high momentary current surge occurring when the coil is energized. The "HOLDING AMPS" (sometimes called running amps) refers to the continuous current draw following the inrush.

To verify correct coil voltage, measure resistance of coil while coil is at room temperature. See Table 1 of Resistance Values below.

Coils can be continuously energized without overheating or failure. When coil has been energized for a long period, the surface will become hot to the touch; this is normal. Coil should only be energized while on solenoid tube; otherwise immediate coil burnout may occur.

TABLE 1

Voltage	Frequency (Hertz)	Inrush Amps	Holding Amps	Resistance at Room Temperature (Ohms)
115VAC	60	0.73	0.24	56±6
	50	0.93	0.31	56±6
208/230VAC	60 (208V)	0.32	0.11	226±23
	60 (240V)	0.41	0.14	226±23
	50 (230V)	0.47	0.16	226±23
24VAC	60	3.42	1.14	2±.2
	50	4.56	1.52	2±.2
24VDC	DC	1.2	1.2	20±2

LONG LIFE BEACON PILOT LIGHTS

Hansen long life Beacon Pilot Lights incorporate a totally encapsulated, unique secondary wound coil and LED light in a compact disc. The



pilot lights require no additional wiring. Simply place Beacon Pilot Light and o-ring on top of coil and hand tighten with the Pilot Light Knob. The Beacon Pilot Light will light when power is flowing through the coil. Note: Beacon Pilot Lights are for AC voltage coils only.

SERVICE AND MAINTENANCE

If coil is suspected of not working, first check fuses, circuit breakers, control relays and switches leading to coil to be sure they are working properly and that power is reaching the coil. Be sure line voltage is within 85% to 110% of marked coil rated voltage, see Table 2 below.

TABLE 2

Rated Voltage	Minimum Voltage (85%)	Maximum Voltage (110%)
115V	98V	126V
208/230V	177V	253V
24V	20.4V	26.4V

Energize the coil; a single metallic "click" signifies the coil is working. If the "click" is not heard, remove knob and hold a small screwdriver against solenoid tube top while coil is energized; a slight magnetic pull should be detected. If not, check coil winding continuity and resistance. Confirm coil is the correct voltage by comparing resistance as shown in Table 1. Disconnect electrical power and isolate coil from field wiring. Use an Ohm meter, or other continuity device, to check the resistance between the two power leads coming from the coil. If coil resistance is infinite, replace coil. Before replacing any coil, the cause of failure should be determined and rectified (i.e. missing parts, plugged solenoid tube or plunger, worn out parts, over voltage, etc.).

PRINCIPLES OF OPERATION

When energized, the flow of electricity through the coil winding creates a magnetic field. Inside this field is the solenoid tube and plunger. The pull of the magnetic field is strong enough to lift the plunger off the pilot seat orifice (typical of a normally closed solenoid tube and plunger). When de-energized, the magnetic field is broken and the plunger returns to close the pilot seat orifice.

HANSEN SOLENOID COIL INSTALLATION

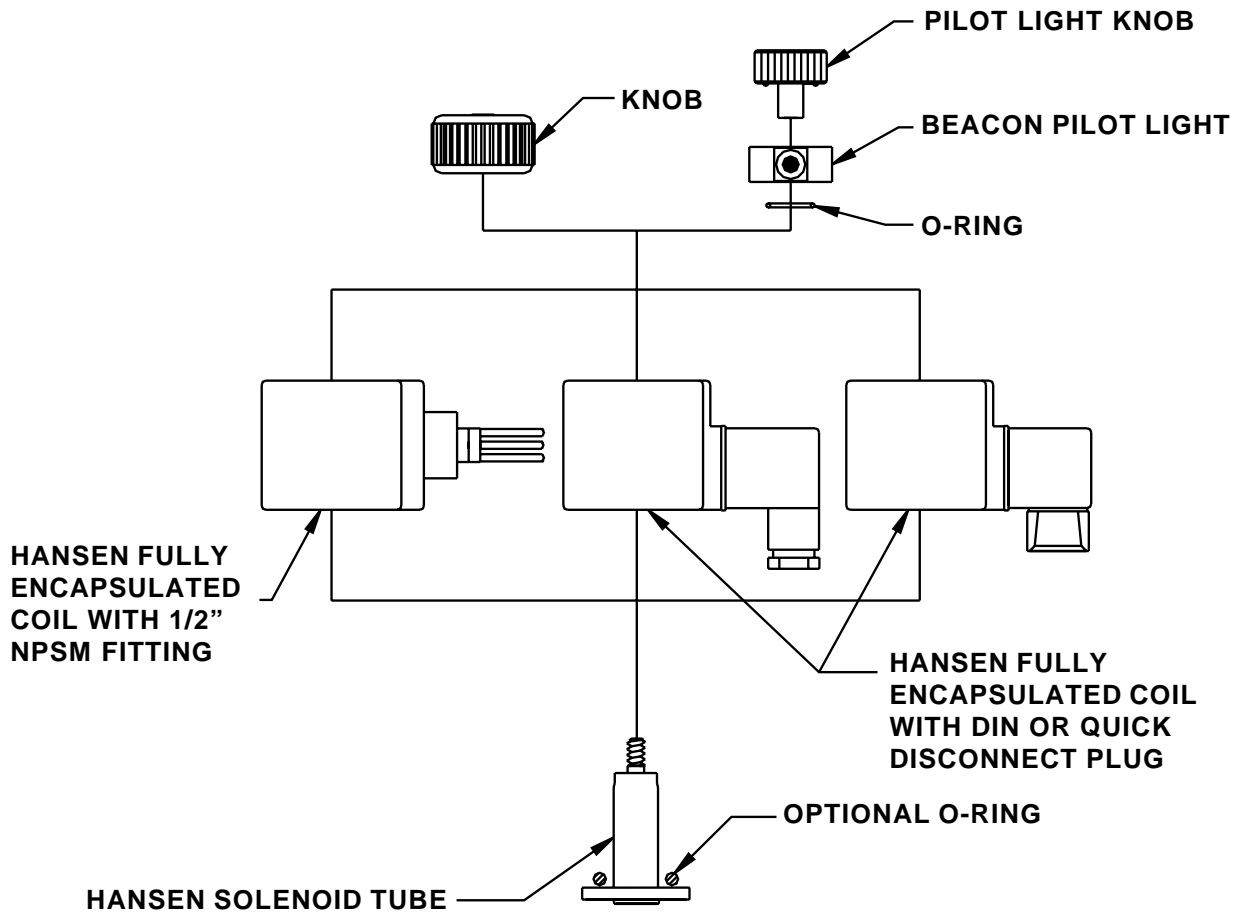

COIL CLIP ASSEMBLY WITH DANFOSS SOLENOID TUBE

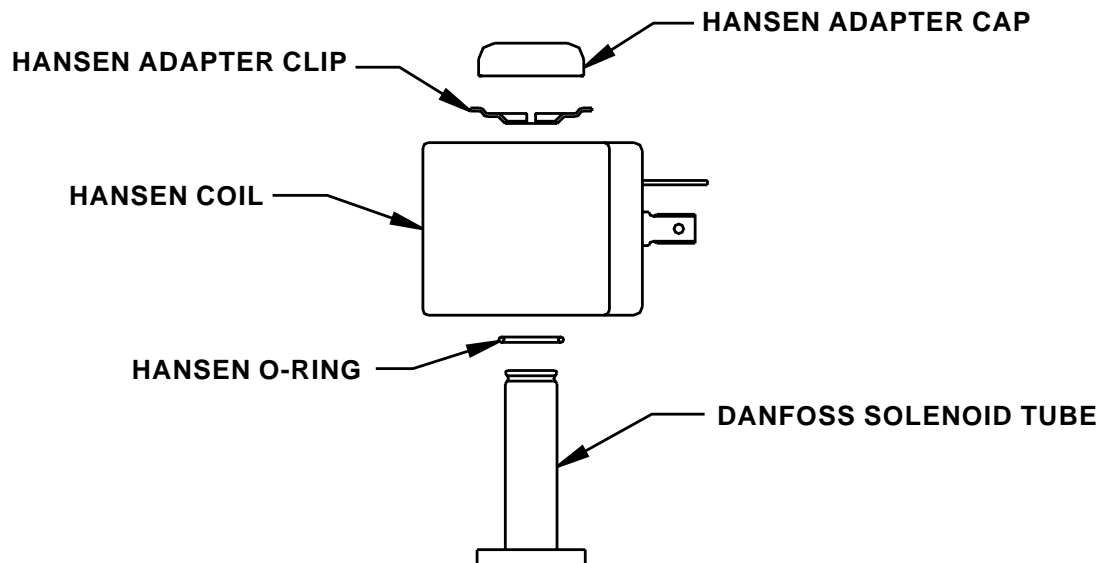

PARTS LIST

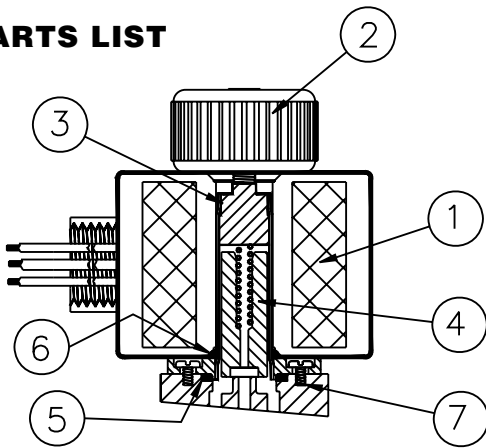

Item	Description	Qty	Part No.
1	Fully Encapsulated Coil	1	See Below
2	Coil Knob	1	70-0579
Solenoid Tube/Plunger Kit <i>Above kit consists of:</i>		1	70-1059
3	Solenoid Tube	1	70-0298
4	Plunger	1	70-0295
5	Solenoid Tube Gasket	1	70-0301
6	O-Ring	1	75-0340
7	Screws (4)	1	70-0297

CAUTION

Coils have been designed specifically for use with Hansen valves on refrigeration systems. They can also replace the same size Danfoss coils. Instructions and related safety precautions must be completely read and understood before selecting, using or servicing coils. Only knowledgeable, trained refrigeration mechanics should install, operate or service coils. Stated temperature and pressure limits should not be exceeded. Do not remove solenoid tube from valve unless system has been evacuated to zero pressure. See also Safety Precaution Sheet supplied with product.

WARRANTY

Hansen electrical and electronic parts are guaranteed against defective materials or workmanship for 90 days F.O.B. factory. All other components are guaranteed for one year F.O.B. factory. No consequential damages or field labor is included.

ORDERING INFORMATION FOR SOLENOID COILS AND PILOT LIGHTS

Standard Coil Kit, 18" Leads

(includes coil, knob and o-ring)

115V 70-1085
230V 70-1086
24AC 70-1087



Replacement Coil Only, 18" Leads

115V 70-0580
230V 70-0581
24AC 70-0582



Plug-in Coil Kit, Less Socket

(includes coil, knob and o-ring)

115V 70-1088
230V 70-1089
24AC 70-1090
24DC 70-1091



Replacement Coil Only, Plug-in Coil

115V 70-0584
230V 70-0585
24AC 70-0586
24DC 70-0583



Coil Adapter Kit for Use on Danfoss Valves

70-1104

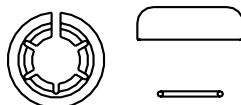

Plug-in Coil Kit, DIN Connector Socket

(includes coil, knob and o-ring)

115V 70-1092
230V 70-1093
24AC 70-1094
24DC 70-1095



Plug-in Coil Kit, Quick Disconnect Connector Socket

(includes coil, knob and o-ring)

115V 70-1096
230V 70-1097
24AC 70-1098
24DC 70-1099



Pilot Light Kit

(includes coil beacon, knob and o-ring)
(A/C Coils Only)

Red 70-1100
Green 70-1102
Amber 70-1101



HANSEN

Hansen Technologies Corporation
6827 High Grove Boulevard
Burr Ridge, Illinois 60527 USA
Tel: (630) 325-1565 Fax: (630) 325-1572
Toll: (800) 426-7368 <http://www.hantech.com>
© 2005 Hansen Technologies Corporation