



Filter System FS250

## Specifications, Applications, Service Instructions & Parts

### LIQUID REFRIGERANT FILTER SYSTEM

For Ammonia and Halocarbon  
Industrial Systems

**CRN**  
Canadian Registration

## INTRODUCTION

The Liquid Refrigerant Filter System features a filter construction that removes much smaller dirt particles than conventional liquid strainers. The “brains” of the filter system monitor the pressure drop across the filter and can alert the operator when the filter needs cleaning. The fully-assembled filter system comes complete with the valves and controls needed, as shown above, to quickly and safely pump-out the filter system for filter cleaning.

Abrasive particles can enter a refrigeration system in a variety of ways, most commonly during installation when weld slag and dirt are present. These abrasives can cause problems, such as valve sticking and wear on pump seals and compressors. Over time, the damage can escalate. Moving parts can become severely worn and system performance declines. Downtime and labor costs to clean system valves is expensive. An effective solution to these problems is the Hansen Liquid Refrigerant Filter System, which is especially designed to remove even fine particles from refrigeration systems. This high-flow filter system has a rugged ductile iron body and a 120 mesh stainless steel filter element. It is suitable for ammonia, R22, R134a, and other approved refrigerants.

## KEY FEATURES

Oversize, pleated screen area of 270 in<sup>2</sup> (1742 cm<sup>2</sup>).

Extra-fine 120 mesh (125 micron rating) stainless steel filter element.

Filter can be cleaned, not a throwaway element.

A differential pressure gauge indicates when the filter needs cleaning

The innovative pump-out feature provides fast, safe, easy servicing.

Fully assembled and tested.

Welded construction for leak-free operation.

## APPLICATION

For most effective results, the Hansen Liquid Refrigerant Filter System should be installed at the discharge of the liquid overfeed pump or on the high-pressure liquid line after the high-pressure receiver. Installing the filter on the inlet of a pump is not recommended because it can cause flashing of the saturated refrigerant liquid and consequential cavitation of the pump. It is particularly important to have a filter system operational during system start-up to remove the dirt before it can collect in sufficient quantity to cause valves to stick or damage bearings and seals.

## FILTRATION EFFICIENCY

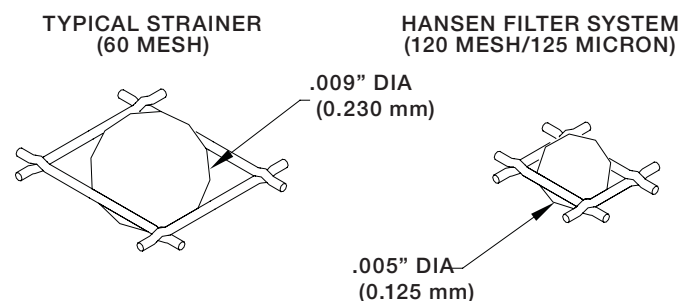

*Shown enlarged for representation*

## MATERIAL SPECIFICATIONS

Body: Ductile iron, ASTM A536, (nodular iron GGG40), 65,000 psi tensile

Screen: Stainless steel, 120 mesh (125 micron rating), 60 mesh available

O-rings: Neoprene

Gaskets: Nonasbestos, graphite composite

Drain plug: 3/8" NPT

Output: SPST Switch, 50 watts maximum load

(i.e. 0.43 amps resistive at 115VAC)

Safe Working Pressure: 400 psig (27 bar)

Operating Temperature: -60° to +240°F (-50° to +115°C)

## ADVANTAGES

The Hansen Filter System uses several innovative design features for safe and reliable refrigerant filtration. The extra-fine 120 mesh, reusable filter element traps tiny abrasive particles that can easily evade commonly-used 60 mesh strainers. A reliable differential pressure gauge, which can be connected to an alarm, alerts operators when the filter element needs cleaning. A unique pump-out feature is designed to make servicing safe and easy. A built-in HA2B pressure-relief regulator helps prevent pressure inside the body from exceeding 300 psig (20.7 bar).

## CONSTRUCTION

The filter system can be broken down into two basic components—the filter and the “brains.” The filter is the component that traps dirt and other material, removing it from the liquid refrigerant. The filter element can be cleaned when needed instead of replacing it. The “brains” of the filter system monitor the pressure drop across the system. As the filter element removes more dirt and foreign material from the refrigerant, the pressure drop increases. When the pressure drop is large enough, the “brains” can alert the operator that the filter element needs cleaning. The “brains” of the filter system also incorporate the pump-out feature. This feature allows for safe, fast, and easy servicing of the filter element or the filter system as a whole.

## DIFFERENTIAL PRESSURE GAUGE

The pressure differential gauge has a normally open reed switch that can be connected to an alarm or light to indicate a clean or dirty filter element. As the pressure differential increases to the set point, the single pole, single throw (SPST) reed switch is closed. The switch is rated at 50 watts (0.43 amp resistive at 115 volts AC, for example). Do not exceed this rating. See page 7 for a sample wiring diagram and the procedures for adjusting the position of the reed switch.

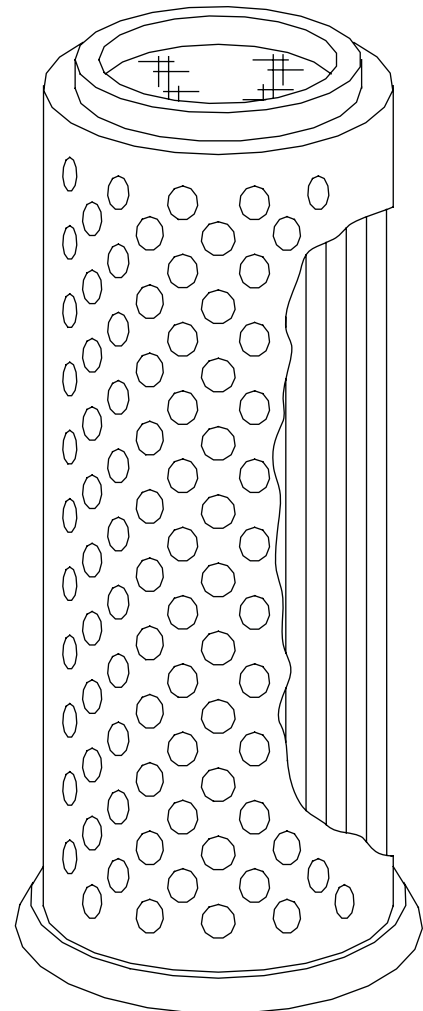
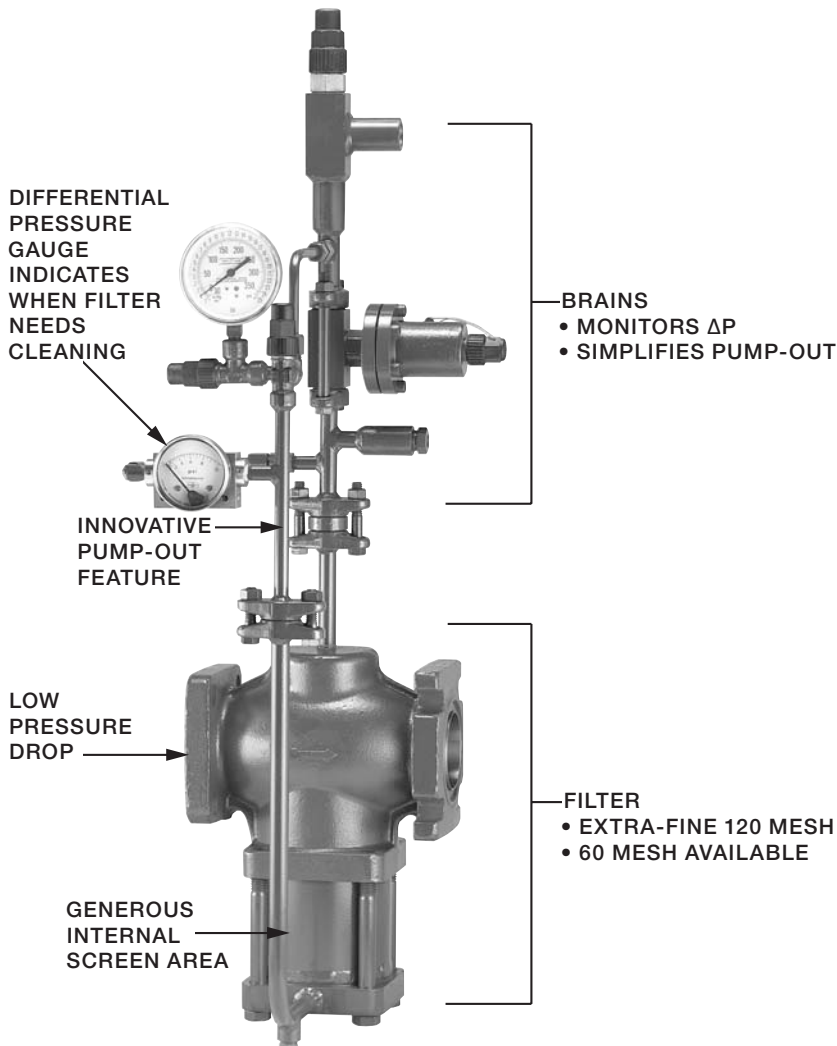

FILTER ELEMENT

## INSTALLATION

Protect the interior of the filter system from excessive dirt and moisture during storage and installation. The filter must be installed vertically, in a horizontal line, as shown in the applications on page 4 and page 5, with the gauges on top. It should be easily accessible for service, allowing sufficient space below the filter housing to remove the filter element for cleaning. See the installation dimensions on page 8 for clearance dimensions. Match the arrow on the filter body with the direction of refrigerant flow. The filter system's pump-out line should be directed to a pump recirculator vessel, suction trap vessel, or proper plant pump-out line.

For proper flange gasket sealing, care must be taken when threading or welding to assure flanges are parallel to each other and perpendicular to pipe. Also, gaskets should be lightly oiled and all bolts and nuts must be tightened evenly. Tighten flange bolts and nuts evenly to provide proper sealing and to avoid damage to the gaskets or flanges. Before putting the filter system into service, all pipe weld connections should be tested for leaks at pressure levels called for in appropriate codes. This filter system is outfitted for, but does not include, a required pressure relief valve. A 3/8" NPT connection exists for a possible oil drain valve. Dual filtration (using two filter systems) may be desired for a large refrigeration system where continuous filtering and frequent cleaning are needed. See below for examples of single and dual filter system installations.

### SINGLE FILTER SYSTEM WITH BYPASS

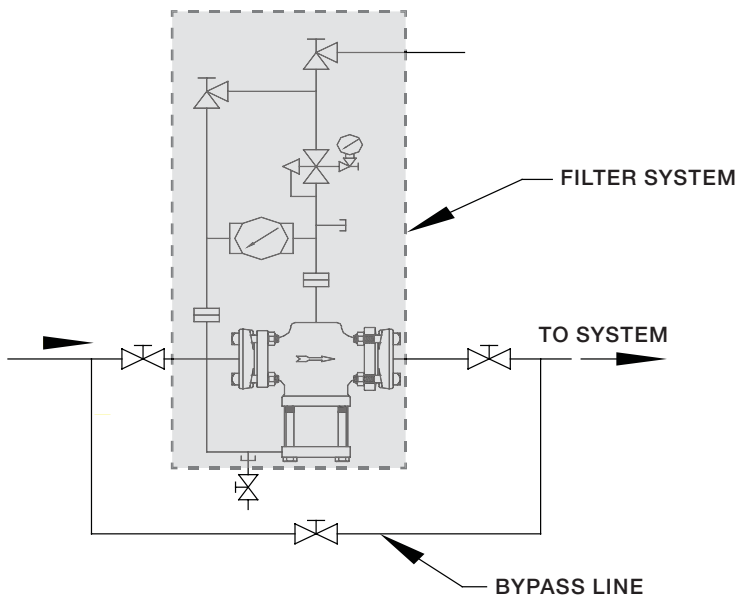

### DUAL FILTER SYSTEM

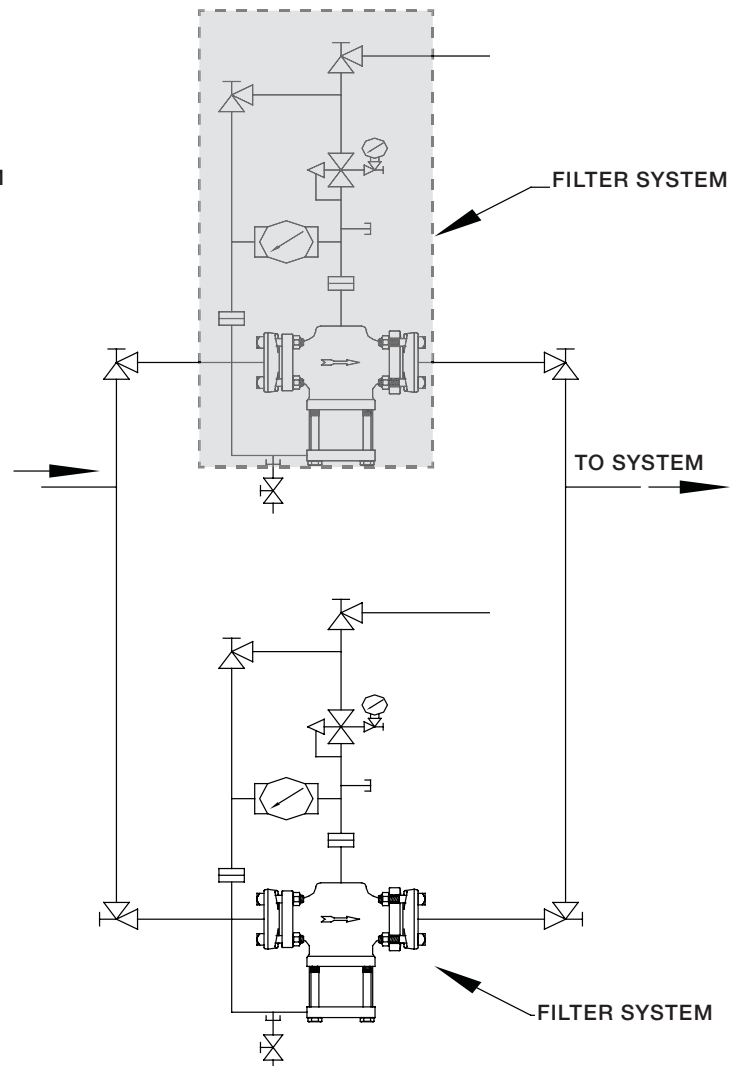

# TYPICAL APPLICATIONS

## FILTER SYSTEM ON A HIGH PRESSURE RECEIVER

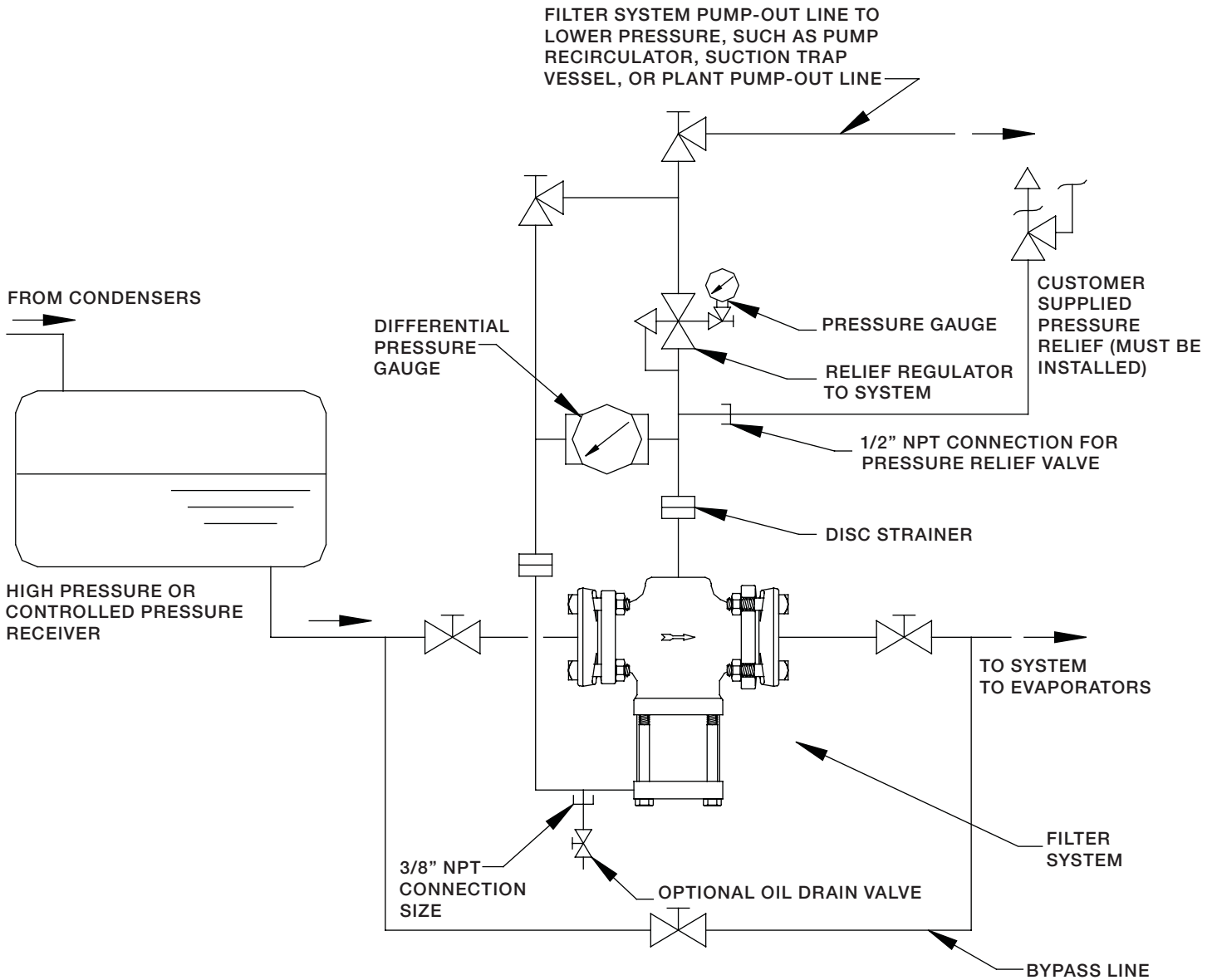

The above diagram depicts a fictional refrigerant piping arrangement. It is intended only to be a guide for explaining filter system typical applications. It should not be used for construction.

# TYPICAL APPLICATIONS

## FILTER SYSTEM ON A PUMP RECIRCULATOR

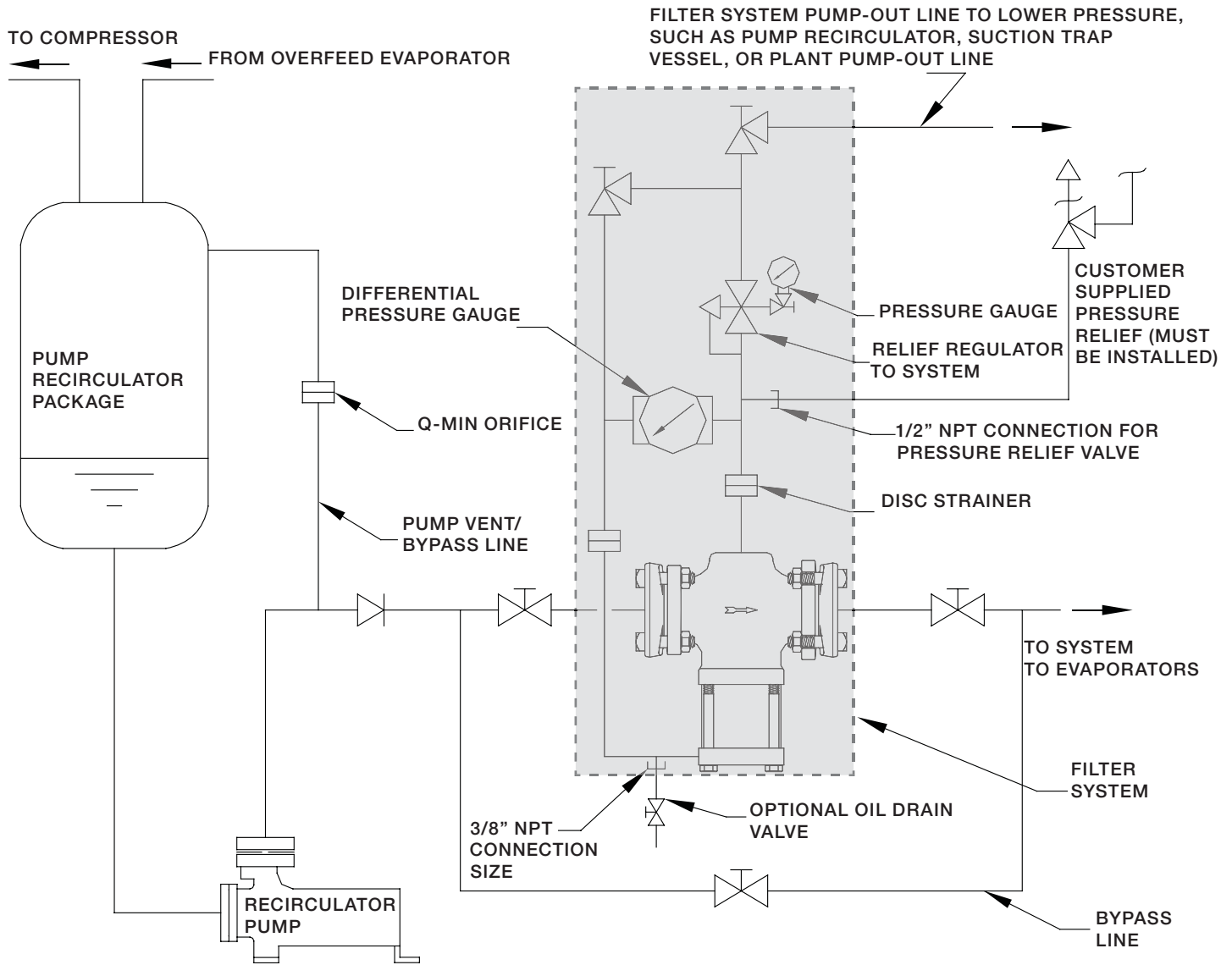

The above diagram depicts a fictional refrigerant piping arrangement. It is intended only to be a guide for explaining filter system typical applications. It should not be used for construction.

## MAINTENANCE AND SERVICE

The Hansen filter system has a unique pump-out feature to make servicing safe and easy. By manually opening and closing a series of valves as described below, the filter system can be pumped-out to prepare it for servicing. As a result, normal operation of the refrigeration system can remain undisturbed and refrigerant loss can be minimized.

**To pump out:** Operate the valves in the following sequence:

- Open valve A.
- Close valve B.
- Make sure valve F is open.
- Close valve D.
- Open valve C.

Allow the filter system to pump-out liquid refrigerant. If connected to low-pressure suction below freezing, wait for the frost to melt from the filter body and piping. Also, wait for the pressure to reduce to the pressure of the pump-out vessel. Next, close valves C and F. Using standard refrigeration system procedures, reduce the pressure in the filter system to atmospheric pressure. If installed, use the drain valve labeled E on the piping schematic to drain any remaining oil in the filter. With all refrigerant removed (pumped out to zero pressure), open the filter housing by first carefully loosening the filter housing bolts and cracking the O-ring seal to

verify zero pressure. Disconnect the flange union and filter housing from the filter body by loosening the bolts, allowing the pressure to equalize to atmospheric, and then removing the four filter housing bolts. Lower the filter housing to remove the filter element. Clean the filter element as described in the FILTER ELEMENT CLEANING section.

**To reassemble:** 1) Install a new O-ring seal on the filter element if needed. 2) Apply a light amount of oil on filter housing O-ring and position it on filter housing, as shown on page 8. 3) Inspect and, if necessary, replace the flange union gasket. 4) Verify that the spring is inside the filter housing. 5) Place the filter element into the filter housing, as shown on page 8. 6) Carefully reinstall the filter housing, making sure the filter housing and filter body properly seat. Torque the flange union bolts to 50 ft-lbs and the filter housing bolts to 120 ft-lbs. Verify valve C is closed. Close valve E (if opened to drain oil). Pressure test for leaks before returning to service. Put the filter system back into service by operating valves in the following sequence. 1) Open valve F. 2) Open valve D. 3) Open valve B. 4) Close Valve A. The filter system is now in normal operation.

## SAFETY

Refrigerant can cause injury, especially to the eyes and lungs. Carefully follow the maintenance and service procedures listed above. See also the CAUTION statement on the back page.

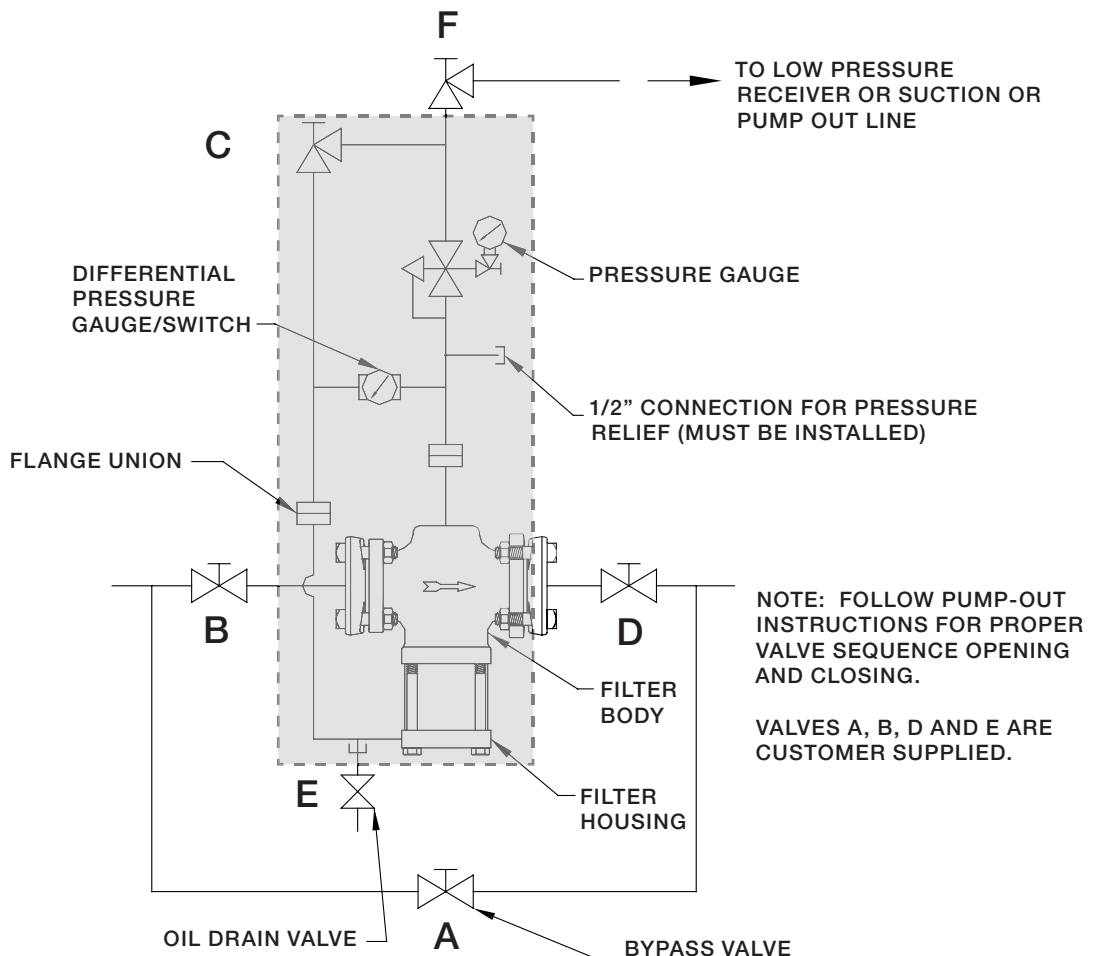

## CAPACITIES

### PRESSURE DROP FOR HANSEN PUMPS

PUMP	MAXIMUM GPM	ΔP (PSID) R-717	ΔP (PSID) R-22
CAM 1/3	14	0.02	0.04
CAM 2/2, CAM 2/3	32	0.10	0.24
CAM 2/5	32	0.10	-
CNF 32-160	60	0.40	-
CNF 40-160 CNF 40-200	98	1.00	2.25
CNF 50-160 CNF 50-200	185	3.60	8.0

The above chart gives approximate pressure drops for the pump sizes listed, assuming a clean 120 mesh filter element, at 0°F (-17.8°C) liquid.

### DIFFERENTIAL PRESSURE GAUGE SWITCH ADJUSTMENT

The pressure switch comes precalibrated from Hansen to activate at 7 psid (0.5 bar). If adjustment is needed in the field, such as when the normal pressure drop is 7 psid or higher, first disconnect the switch wiring at the back of the gauge and connect it to an Ohmmeter. Loosen the switch adjustment locking screw on the back of the differential pressure gauge.

If the Ohmmeter is reading infinite resistance, the switch is open. Slide the switch toward the high pressure port until the Ohmmeter reads zero resistance. This is the point of the normal operating pressure differential for the filter system. Then, slide the switch toward the low pressure port approximately another 1/8". Tighten the switch adjustment locking screws and reconnect the wiring. Additional adjustment may be necessary.

If the Ohmmeter is reading zero resistance, the switch is closed. Slide the switch toward the low pressure port until the Ohmmeter reads infinite resistance. This is the point of the normal operating pressure differential for the filter system. Continue sliding the switch toward the low pressure port approximately 1/8". Then, tighten the switch adjustment locking screw and reconnect the wiring. Additional adjustment may be necessary.

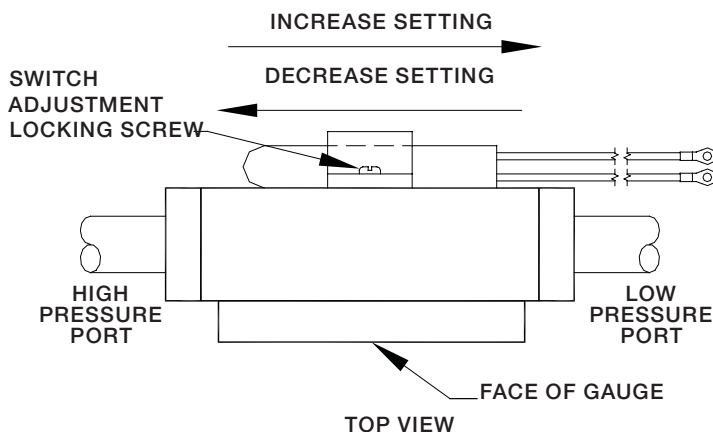

Adjusting the Set Point for the Pressure Switch

### PRESSURE DROP AT VARIOUS FLOW RATES

PRESSURE DROP (PSID)	R-717 GPM	R-22 GPM
0.5	69	47
1	97	66
2	137	94
3	168	115
4	194	133

The above chart is based on 0°F (-17.8°C), assuming a clean 120 mesh filter element, at 0°F (-17.8°C) liquid.

### WIRING FOR THE DIFFERENTIAL PRESSURE GAUGE SWITCH

The pressure switch is a single pole, single throw (SPST) reed switch. Wire the switch in series with the coil of an actuating relay. The actuating relay can be wired to an indicator light and/or an alarm. The total wattage of the circuit must not exceed 50 watts. A typical wiring diagram is shown below.

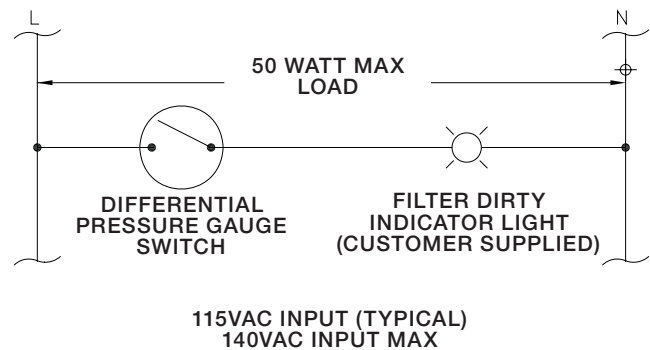

Typical Wiring Diagram for the Pressure Gauge Switch

### FILTER ELEMENT CLEANING

To clean the filter element, first remove the O-ring from the element. Then, soak the element in solvent to loosen debris. The amount of time the element should soak depends on the amount and type of debris trapped in the filter element. Next, blow out the solvent and debris from the outside in, not from the inside out. Relubricate and reinstall the O-ring on the filter element. Finally, reassemble the filter system.

Note: A pressure-relief valve is required, but not supplied. Refer to Hansen Bulletin K109 for pressure-relief valves.

## CAUTION

Hansen filter systems are for refrigeration systems only. These instructions and related safety precautions must be read completely and understood before selecting, using, or servicing these filter systems. Only knowledgeable, trained refrigeration technicians should install, operate, or service these filter systems. Stated temperature and pressure limits should not be exceeded. The filter housing should not be removed unless the system has been evacuated to zero pressure. See also Safety Precautions in the current List Price Bulletin and the Safety Precautions Sheet supplied with the product. Escaping refrigerant may cause injury, particularly to the eyes and lungs.

## WARRANTY

All Hansen products, except electronics, are guaranteed against defective materials or workmanship for one year F.O.B. factory. Electronics are guaranteed against defective materials or workmanship for 90 days F.O.B. factory. No consequential damages or field labor is included.

## INSTALLATION DIMENSIONS

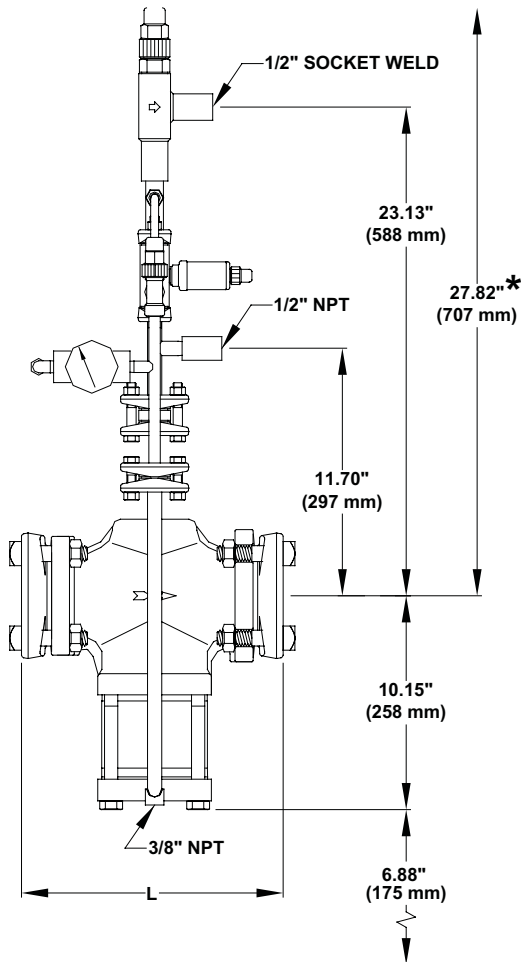

NPT = NATIONAL PIPE THREAD

CLEARANCE FOR FILTER REMOVAL

\*PIPING CAN BE RECONFIGURED TO MINIMIZE HEIGHT

FLANGE CONNECTION SIZE	"L" DIMENSION
1-1/2", 2"	15.63" (397 mm)
2-1/2", 3"	13.01" (330 mm)

## ORDERING INFORMATION

CAT NO	DESCRIPTION	FLANGE CONNECTION
FS250	Filter System with differential pressure monitoring/protection package	1-1/2", 2", 2-1/2", 3" (40, 50, 65, 80 mm)
F250	Filter only less differential pressure monitoring/protection package	

FS250 Filter systems have a 3/8" NPT drain plug connection, a 1/2" socket weld pump-out line connection, and a 1/2" NPT pressure relief connection.

**TO ORDER:** Specify catalog number and flange connection size. Socket weld is standard. Weld neck is available.

## REPLACEMENT PARTS

DESCRIPTION	PART NO
Flange Gasket	75-0125
Differential Pressure Gauge	78-0087
<b>Filter Replacement Kit (120 Mesh)</b>	<b>78-1011</b>
<i>Above kit consists of:</i>	
Flange Union Gasket	70-0065
Filter Element O-Ring	78-0085
Filter Element	78-0088
Filter Housing O-Ring	78-0121
<b>Filter Replacement Kit (60 Mesh)</b>	<b>78-1012</b>
<i>Above kit consists of:</i>	
Flange Union Gasket	70-0065
Filter Element O-Ring	78-0085
Filter Element	78-0130
Filter Housing O-Ring	78-0121

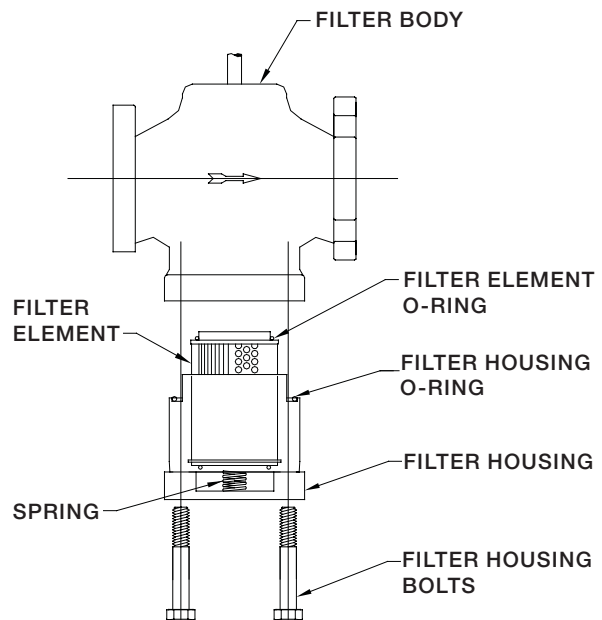

# HANSEN

Hansen Technologies Corporation  
 6827 High Grove Boulevard  
 Burr Ridge, Illinois 60527 USA  
 Tel: 630.325.1565 Fax: 630.325.1572 Toll: 800.426.7368  
 Email: info@hantech.com Web: www.hantech.com  
**USA · Asia · Europe · India · Latin America · Middle East**  
 © 2006 Hansen Technologies Corporation