

## SEAT RING REMOVAL INSTRUCTIONS

Hansen pressure regulators and solenoid valves, port sizes 1<sup>1</sup>/<sub>2</sub>" through 6", have removable seat rings. These seat rings are made of corrosion-resistant stainless steel and normally should not require replacement. However, to access the V-Port/seat and closing spring for inspection, the seat ring must first be removed.

**CAUTION:** Before attempting to work on any valves, carefully read and understand the Safety Precautions in the current list price bulletin and Safety Precautions sheet supplied with product. Refer to the Service and Maintenance Section of the specific valve bulletin for general disassembly instructions.

### STEP 1:

With the valve adapter piston already removed, take out the small hex head seat screw by turning it counterclockwise using a <sup>3</sup>/<sub>8</sub>" (10 mm) socket connection to a ratchet via an extension.

### STEP 2:

Turn the seat ring counterclockwise using one of the following four methods:

#### METHOD A:

**TOOLS NEEDED:** Seat ring tool and a <sup>1</sup>/<sub>2</sub>" drive ratchet with extension. This seat ring tool is made by Hansen Technologies specifically for seat ring removal or insertion. Part numbers for these are in drawing on right; contact Hansen to order.

Insert extension with attached ratchet inside the center hole of the seat ring tool. Carefully place seat ring tool inside valve on top of V-Port. Push downward until the V-Port is below the seat ring while aligning seat ring tool notches with seat ring ears. Now engage the seat ring tool and turn counterclockwise to loosen seat ring.

#### METHOD B:

**TOOLS NEEDED:** Two large wrenches. Minimum wrench size: 10" for the 1<sup>1</sup>/<sub>2</sub>", 2" valves; 12" for 2<sup>1</sup>/<sub>2</sub>", 3", 4" valves; 15" for 5", 6" valves.

To avoid damage to piston bore, drape piston bore with a thick cloth before inserting wrenches into valve. Put one wrench (handle-end down) inside the valve and rest the handle end of the seat ring up against the base of the seat ring up against the base of a seat ring ear. Position the second wrench (handle end down) in the same manner but on the OPPOSITE side of the seat ring. The wrenches should be crossed and be approximately at 60° angles to the seat ring. Use a pulling motion on one wrench while pushing the other wrench, exerting equal force on each tool, to create a twisting (counterclockwise) motion until the seat ring loosens.

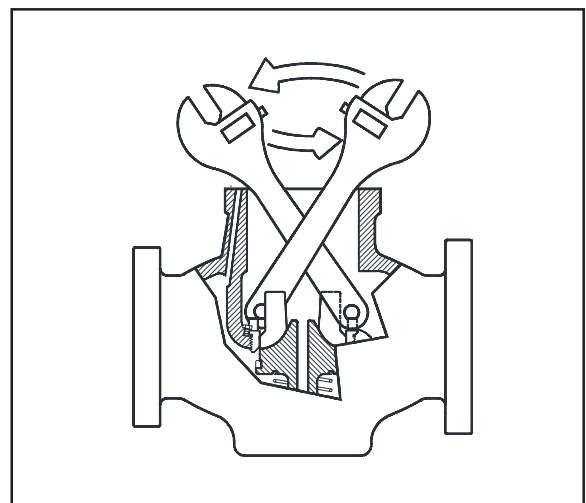
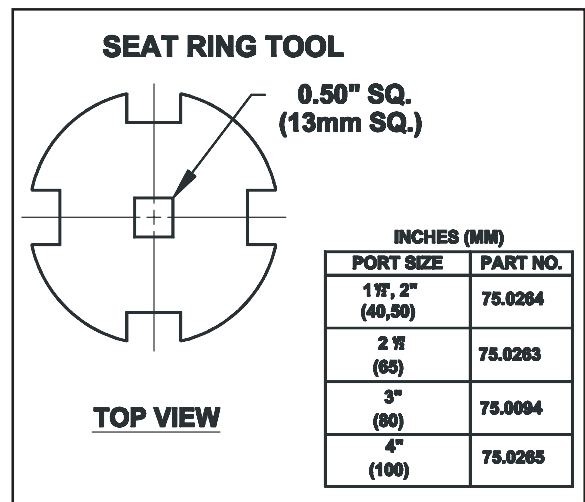

### METHOD C:

TOOLS NEEDED: Hammer and punch (or screw driver)

Safety goggles should be worn when performing this procedure. For valves 1 1/2" to 4", the punch should enter through the valve outlet. Place tip of punch at base of a seat ring ear. Tap the end of the punch with the hammer, making sure tapping motion is forcing the seat ring to turn counterclockwise. NOTE: The 5" and 6" valve are integral butt weld end only, therefore this method is not possible once valve is installed.

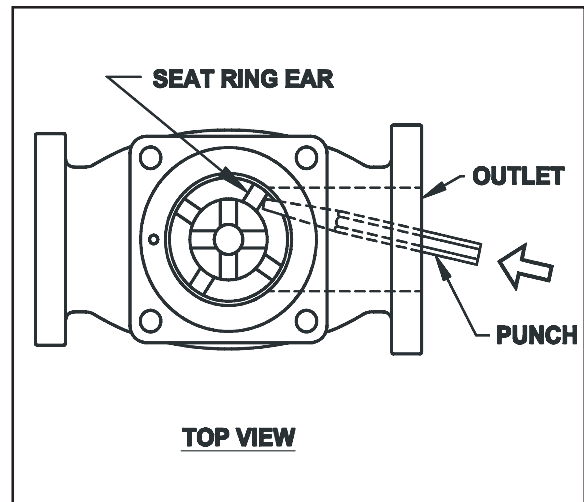

### METHOD D:

TOOLS NEEDED: Two large wrenches and a small wrench. (Other bar-like tool can be substituted for small wrench.)

Push down on V-Port to access seat ring. Insert small wrench inside valve and lay it flat across the seat ring. (Length of small wrench should be about the diameter of the seat ring.) Each end of the wrench should butt up against the side of an ear on opposite sides of the seat ring. Tighten the head of the first large wrench around the middle of the small wrench. Now tighten the head of the second large wrench around the handle of the first large wrench in a counterclockwise direction until seat ring loosens.

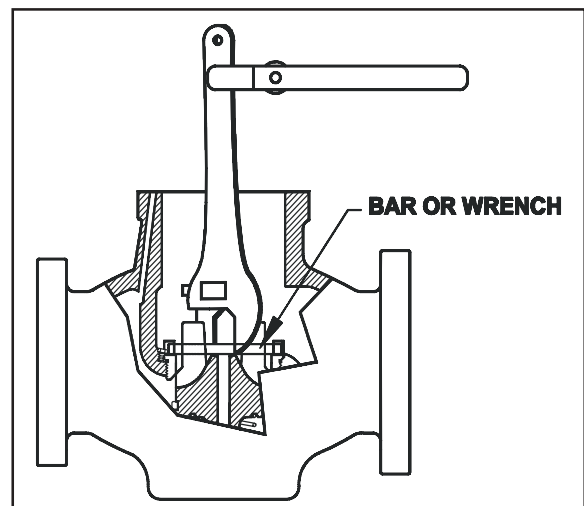

### STEP 3:

Once it is loose, remove seat ring by hand. Look at the seat seal O-ring. Replace the O-ring if it appears swelled or cracked, or if it has small cuts. Lightly lubricate new O-ring with refrigerant oil and install on seat ring.

### STEP 4:

Remove, inspect, clean, and repair (if necessary) V-Port and closing spring. Reinstall these parts and seat ring.

### STEP 5:

Tighten seat ring with torque wrench or other means. Apply 75 ft-lbs (102 newton-meters) torque to insure tight seat ring-to-valve body seating.

### STEP 6:

Re-install seat screw. Re-assemble valve and leak test in accordance with current valve bulletin.