



HCK2: Gas-Powered Suction Stop Valve

### INTRODUCTION

These heavy-duty, flanged, gas-powered suction stop valves are designed to control the flow of refrigerant in large industrial and commercial applications. They remain normally open via a spring and require no pressure drop to operate. Valves are best installed on their side for better conveyance of liquid overfeed or oil and to avoid trapping. A single pilot solenoid valve is required to control a higher pressure refrigerant gas which closes these valves during defrosting.

### APPLICATIONS

These valves are ideally suited for low temperature applications to positively close, during defrost, the following: suction lines, liquid overfeed and flooded evaporator gas return lines, as well as gravity liquid and gas lines. Because they are gas powered to close, these valves operate reliably even under viscous oil conditions. They are suitable for ammonia, R22, R134a, and other compatible refrigerants.

### ADVANTAGES

Unique spool type piston/seats are more resistant to dirt than typical full skirted piston designs. The ductile iron body is much stronger and tougher than grey iron or "semi-steel" iron. Protective pilot line disc strainers are included. Manual opening stems are standard for positive opening during servicing or trouble shooting systems. Flange-to-flange dimension and flange patterns are the same as R/S CK-2; these valves can be "dropped-in" without main line piping changes (except 1/4").

## Specifications, Applications, Service Instructions & Parts

**HCK2, HCK2W  
GAS-POWERED  
SUCTION STOP VALVES  
1 1/4" through 6" PORT  
(32 through 150 mm)**

**Flanged  
1 1/4" through 4"  
FPT, SW, WN, ODS  
for refrigerants**

ISO 9002

### KEY FEATURES

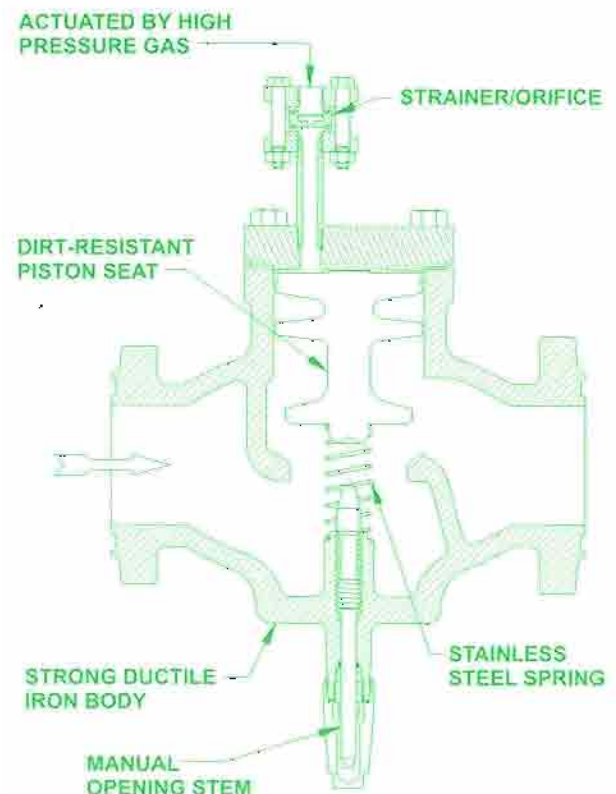

### ADDITIONAL FEATURES

- No pressure drop required to open
- Durable metal-to-metal seating
- Tough ductile iron piston
- Pilot line disc strainer
- Dimensionally replaces R/S type CK-2

## MATERIAL SPECIFICATIONS

Body: Ductile iron, ASTM A536, 65,000 psi tensile (nodular iron GGG-40); 5" & 6": Cast steel  
 Top Cover: Steel  
 Piston/Seat: Ductile iron, ASTM A536;  
 1½" only: stainless steel  
 Piston Seal (5" & 6" only): Teflon®, spring activated  
 Spring: Stainless steel  
 Gaskets: Non-asbestos, graphite composite  
 Stem: Plated steel  
 Stem Seal: O-ring plus graphite composite packing  
 Seal Cap: Steel, zinc chromate plated;  
 1½" only: glass filled polymer  
 Companion Flanges: Forged steel (1½" to 4")  
 Safe Working Pressure: 400 PSIG (27 bar)  
 Operating Temperature: -60°F to +240°F (-50° to 115°C)

## OPERATION

These valves are held normally open by means of a spring. When a high pressure refrigerant gas is introduced to the valve through the pilot line inlet, the piston/seat is forced down, compressing the spring and seating the piston/seat firmly on the valve body taper seat. While the HCK2 is designed to withstand the shock of quick closing, if the noise or system or piping shock is excessive, a lower controlled pilot gas pressure may be advisable.

For opening, the high pressure gas source is interrupted and the remaining high pressure gas is bled-off past the piston/seat to the outlet side of the valve. The upstream pressure plus the spring causes the valve to open wide. It is advisable, especially for suction lines exceeding 2", to bleed down the evaporator pressure before opening the HCK2 (See page 7).

Because of the constant bleed around the piston/seat when closed, these valves are recommended where closure is for short periods, as during defrost, or where bleed to suction is not objectionable. When a constant bleed to suction is not desired, use Hansen HS9B gas-powered solenoid valve having piston seal ring and dual pilot solenoid valves.

## INSTALLATION

Protect the interior of the valves from dirt and moisture during storage and installation. These valves may be installed upright or on their sides in either a vertical or horizontal line. Arrow on valve body should be in normal direction of refrigerant flow. System should be free of dirt, weld slag, and rust particles. These valves require only a single pilot solenoid valve to close. A ⅜" (4 mm) port Hansen HS6 pilot solenoid valve with strainer is recommended to control the high pressure gas source to a 2" or smaller HCK2; a ½" (13 mm) port Hansen HS8 solenoid valve with strainer is recommended for 2½" and larger valves. (If using a refrigerant liquid for the high pressure source, a Hansen HS9B gas-powered solenoid valve is recommended, instead of the HCK2.) The field installed pilot solenoid valve must be connected upstream of any hot gas defrost solenoid valve and should be located as close as possible to the main valve. This will help maintain full high pressure gas to top of piston/seat and minimize the amount of high pressure gas to be relieved past the piston/seat upon termination of the high pressure source. An integral orifice inside the pilot line disc strainer helps to retard piston/seat closing velocity. Where two HCK2 valves are to be operated simultaneously, a pilot line disk strainer/orifice assembly should be installed in each pilot line.

**Important:** To avoid system opening pressure shock including liquid slugs from the evaporator after defrost, especially for 2" and larger valves, use a small bypass solenoid valve to equalize evaporator to suction pressure before opening HCK2 suction stop valve. See page 7, Opening shock.

## SUCTION VAPOR CAPACITIES—Tons (1 Ton= 12,000 Btu/hr= 3.517 kW= 3024 kcal/hr)

APPLICATION		PORT SIZE (mm)							
		1¼" (32)	1½" (40)	2" (50)	2½" (65)	3" (80)	4" (100)	5" (125)	6" (150)
R717	+20°F (-6.7°C)	24	58	68	110	155	341	432	556
	0°F (-17.8°C)	20	47	55	90	127	278	353	454
	-20°F (-28.9°C)	16	38	44	73	101	221	281	361
	-40°F (-40.0°C)	12	29	34	55	78	171	216	278
R22	+20°F (-6.7°C)	10	24	28	46	65	143	181	233
	0°F (-17.8°C)	9	21	24	39	55	121	154	197
	-20°F (-28.9°C)	7	17	20	32	45	99	126	162
	-40°F (-40.0°C)	5.9	14	16	26	36	80	101	130
Cv (Kv)		19.8 (17)	47 (40)	55 (47)	89 (76)	126 (108)	276 (236)	350 (300)	450 (385)

Above capacities are based on liquid temperature equal to evaporator temperature and 1 psi (0.07 bar) drop through the valve. For 0.5 psi (0.035 bar) drop, multiply above values by 0.71. For liquid overfeed systems, nominal 2:1 to 5:1 ratio, add 20% to the evaporator load and select a valve based on the increased load. For gravity flooded application, valve should be same port size as properly sized liquid leg or gas line. Consult flooded evaporator manufacturer for proper line sizing.

## INSTALLATION DIMENSIONS

**1/4" through 4"  
(32 mm through 100 mm)**

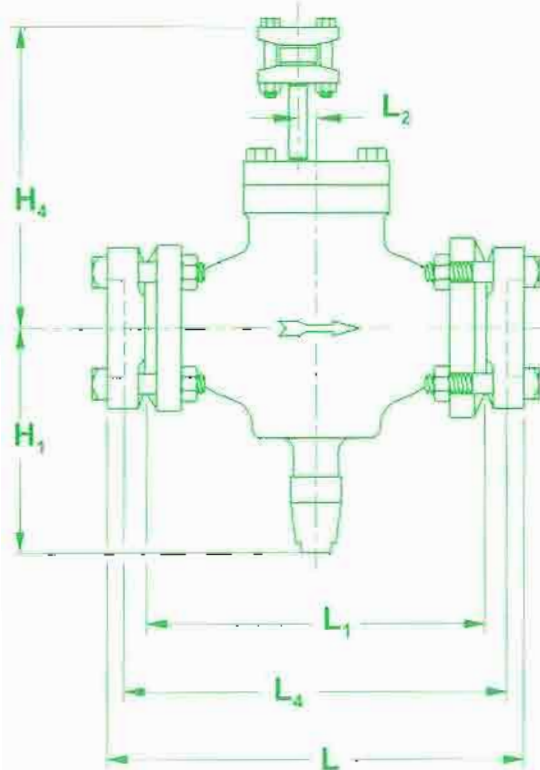

**5" & 6"  
(125 mm & 150 mm)**

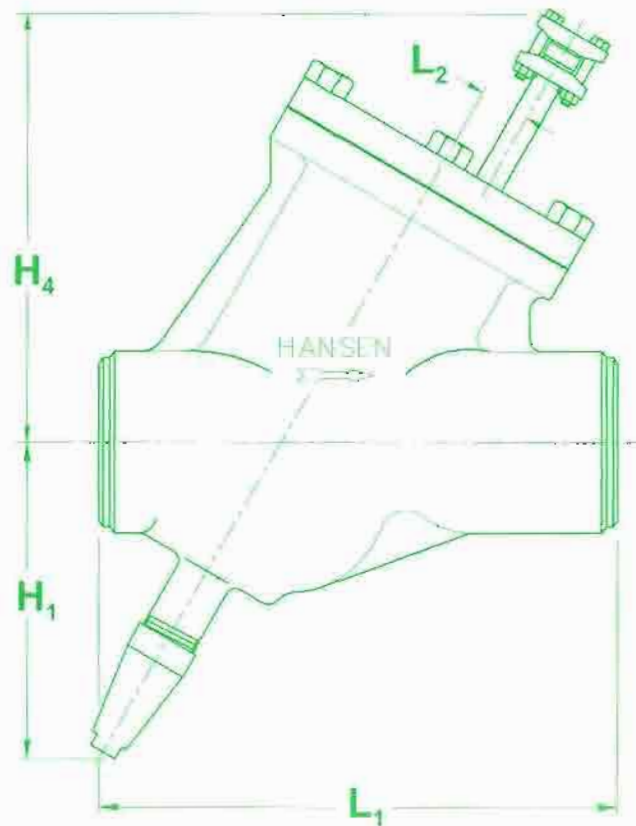

PORT SIZE (mm)	DIMENSIONS (mm)							
	H <sub>1</sub> <sup>†</sup>	H <sub>2</sub>	L		L <sub>1</sub> <sup>†</sup>	L <sub>2</sub>	L <sub>3</sub>	W
			FPT. SW	WN, ODS				
1/4" (32)	4.21" (107)	8.99" (228)	8.20" (208)	8.94" (227)	6.19" (157)	—	7.20" (183)	4.50" (114)
1/2", 2" (40), (50)	7.12" (107)	9.55" (243)	12.39" (315)	13.39" (340)	9.88" (251)	0.86" (22)	10.89" (277)	4.50" (114)
2 1/2" (65)	8.06" (205)	10.23" (260)	13.01" (330)	14.03" (356)	9.88" (251)	1.15" (29)	11.01" (280)	5.62" (143)
3" (80)	8.38" (213)	10.57" (268)	15.38" (391)	16.40" (417)	12.25" (311)	1.15" (29)	13.38" (340)	6.50" (165)
4" (100)	9.88" (251)	11.45" (291)	17.01" (432)	20.51" (521)	14.12" (359)	1.50" (38)	15.01" (381)	8.06" (205)
5" (125)	12.13" (308)	17.00" (432)	—	—	20.40" (518)	2.00" (51)	—	12.75" (324)
6" (150)	12.13" (308)	17.00" (432)	—	—	20.40" (518)	2.00" (51)	—	12.75" (324)

<sup>†</sup>Same as flanged Parker R/S valves; as are flanges, flange gaskets, bolt centers, bolt sizes, and bolt lengths; exception: 1/4" 4-bolt is not available.      \*Allow additional 2.75" for seal cap removal.      W= maximum width of valve.

## HCK2 PARTS LIST 1 1/4" through 4" (32 mm through 100 mm)

ITEM	DESCRIPTION	QTY	PART NO
	<b>Piston/Seat Kit 1 1/4"</b>		<b>75-1057</b>
	<b>Piston/Seat Kit 1 1/2"</b>		<b>75-1073</b>
	<b>Piston/Seat Kit 2"</b>		<b>75-1004</b>
	<b>Piston/Seat Kit 2 1/2"</b>		<b>75-1005</b>
	<b>Piston/Seat Kit 3"</b>		<b>75-1006</b>
	<b>Piston/Seat Kit 4"</b>		<b>75-1018</b>
	Above Kits Consist of:		
1a	Piston/Seat Kit 1 1/4"	1	75-0486
1b	Piston/Seat Kit 1 1/2"	1	75-0597
1c	Piston/Seat Kit 2"	1	75-0282
1d	Piston/Seat Kit 2 1/2", 3"	1	75-0281
1e	Piston/Seat Kit 4"	1	75-0244
2a	Spring 1 1/4"	1	75-0446
2b	Spring 1 1/2", 2"	1	75-0130
2c	Spring 2 1/2"	1	75-0131
2d	Spring 3"	1	75-0195
2e	Spring 4"	1	75-0240
25	Upper Body O-Ring (1 1/4" only)	1	75-0131
26	Lower Body O-Ring (1 1/4" only)	1	75-0130
3a	Cover Gasket 1 1/2", 2"	1	75-0196
3b	Cover Gasket 2 1/2", 3"	1	75-0128
3c	Cover Gasket 4"	1	75-0234
20	Disc Strainer Flange Gasket	2	70-0065
	<b>Gasket Kit 1 1/4"</b>		<b>75-1056</b>
	<b>Gasket Kit 1 1/2", 2"</b>		<b>75-1007</b>
	<b>Gasket Kit 2 1/2"</b>		<b>75-1008</b>
	<b>Gasket Kit 3"</b>		<b>75-1009</b>
	<b>Gasket Kit 4"</b>		<b>75-1017</b>
	Above Kit Consists of:		
25	Upper Body O-Ring (1 1/4" only)	1	70-0131
26	Lower Body O-Ring (1 1/4" only)	1	70-0130
3a	Cover Gasket 1 1/2", 2"	1	75-0196
3b	Cover Gasket 2 1/2", 3"	1	75-0128
3c	Cover Gasket 4"	1	75-0234
4a	Back-up Washer 1 1/2", 2", 2 1/2", 3"	1	75-0245
4b	Back-up Washer 4"	1	50-0351
5a	Stem O-Ring 1 1/4"	1	70-0010
5b	Stem O-Ring 1 1/2", 2", 2 1/2", 3"	1	50-0179
5c	Stem O-Ring 4"	1	50-0253
6a	Stem Washer 1 1/4"	1	70-0026
6b	Stem Washer 1 1/2", 2", 2 1/2", 3"	1	50-0046
6c	Stem Washer 4"	1	50-0247
7a	Packing 1 1/4"	1	70-0025
7b	Packing 1 1/2", 2", 2 1/2", 3"	1	50-0045
7c	Packing 4"	1	50-0248
8a	Packing Nut 1 1/4"	1	70-0019
8b	Packing Nut 1 1/2", 2", 2 1/2", 3"	1	50-0013
8c	Packing Nut 4"	1	50-0251
9a	Seal Cap O-Ring 1 1/4"	1	70-0011
9b	Seal Cap O-Ring 1 1/2", 2", 2 1/2", 3"	1	50-0432
9c	Seal Cap Gasket 4"	1	50-0270
20	Disc Strainer Flange Gasket	2	70-0065
15a	Flange Gasket 1 1/4"	2	70-0132
15b	Flange Gasket 1 1/2", 2"	2	75-0138
15c	Flange Gasket 2 1/2"	2	75-0125
15d	Flange Gasket 3"	2	75-0137
15e	Flange Gasket 4"	2	75-0253

ITEM	DESCRIPTION	QTY	PART NO
10a	Stem 1 1/4"	1	75-0506
10b	Stem 1 1/2", 2", 2 1/2"	1	75-0118
10c	Stem 3"	1	75-0135
10d	Stem 4"	1	75-0242
11a	Seal Cap 1 1/4"	1	50-0411
11b	Seal Cap 1 1/2", 2", 2 1/2"	1	75-0139
11c	Seal Cap 4"	1	50-0260
27	Cover 1 1/4"	1	70-0279
12a	Cover 1 1/2", 2"	1	75-0107
12b	Cover 2 1/2", 3"	1	75-0121
12c	Cover 4"	1	75-0243
13a	Cover Bolts 1 1/2", 2"	4	75-0175
13b	Cover Bolts 2 1/2", 3"	4	65-0057
13c	Cover Bolts 4"	4	75-0291
14a	Body 1 1/4"	1	75-0492
14b	Body 1 1/2", 2"	1	75-0197
14c	Body 2 1/2"	1	75-0221
14d	Body 3"	1	75-0198
14e	Body 4"	1	75-0238
16	Flange (FPT, SW, WN, ODS)	2	FACTORY
17a	Flange Bolt 1 1/4" (5/8"-11 x 2.75")	4	70-0339
17b	Flange Bolt 1 1/2", 2" (5/8"-11 x 3.25")	8	70-0135
17c	Flange Bolt 2 1/2", 3" (7/8"-10 x 3.75")	8	75-0202
17d	Flange Bolt 4" (7/8"-9 x 4")	8	75-0279
18a	Flange Nut 1 1/4" (5/8"-11)	4	70-0136
18b	Flange Nut 1 1/2", 2" (5/8"-11)	8	70-0136
18c	Flange Nut 2 1/2", 3" (7/8"-10)	8	75-0210
18d	Flange Nut 4" (7/8"-9)	8	75-0280
19	Disc Strainer/Orifice Assembly	1	78-0065
20	Disc Strainer Flange Gasket	2	70-0065
21	Nipple (1/2" x 3.5)	1	75-0677
22	Flange 1/2" FPT	2	70-0023
23	Flange Bolt (7/16"-14 x 2.5")	2	70-0054
24	Flange Nut (7/16"-14)	2	70-0055

# HCK2 PARTS LIST 1 1/4" through 4" (32 mm through 100 mm)

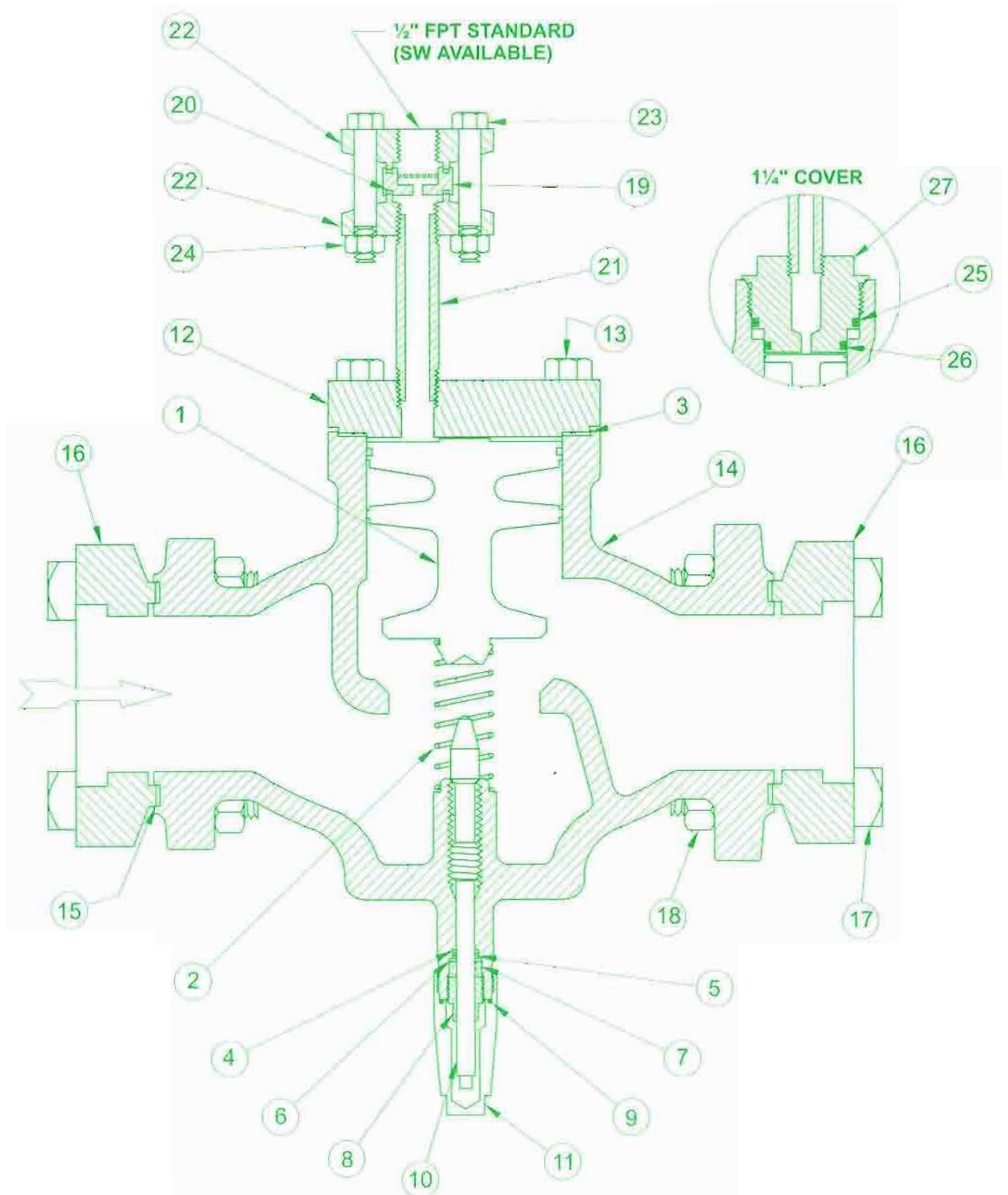

## HCK2W PARTS LIST, 5" & 6" (125 mm & 150 mm)

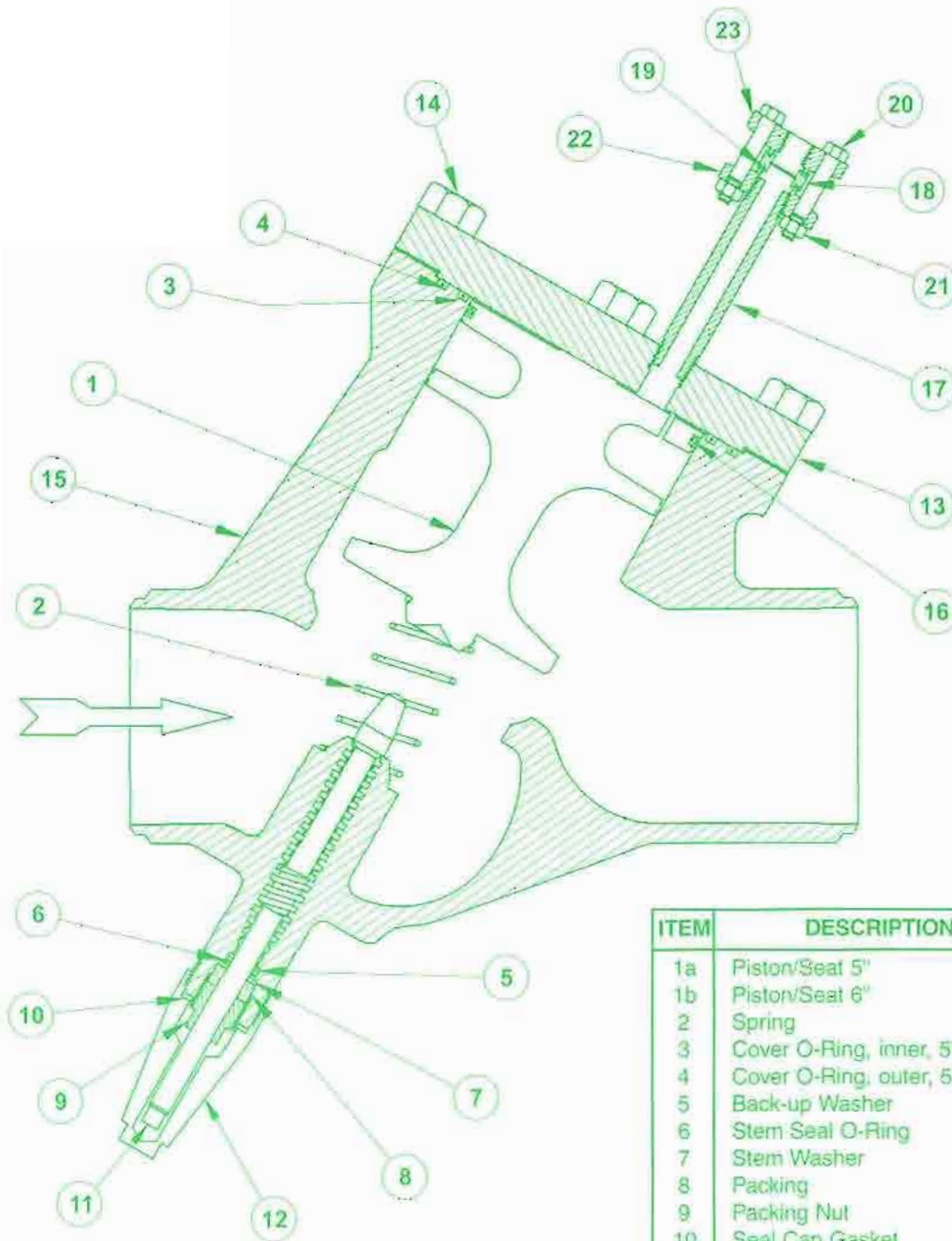

ITEM	DESCRIPTION	QTY	PART NO
1a	Piston/Seat 5"	1	75-0686
1b	Piston/Seat 6"	1	75-0608
2	Spring	1	75-0600
3	Cover O-Ring, inner, 5" & 6"	1	75-0605
4	Cover O-Ring, outer, 5" & 6"	1	75-0606
5	Back-up Washer	1	50-0324
6	Stem Seal O-Ring	1	50-0293
7	Stem Washer	1	50-0299
8	Packing	1	50-0290
9	Packing Nut	1	50-0292
10	Seal Cap Gasket	1	50-0315
11	Stem	1	75-0584
12	Seal Cap	1	50-0304
13	Cover	1	75-0583
14	Cover Bolts	4	75-0604
15a	Body 5"	1	75-0638
15b	Body 6"	1	75-0639
16	Piston Seal	1	75-0602
17	Nipple (1/2" x 6")	1	75-0680
18	Disc Strainer Screen Assembly	1	78-0049
19	Disc Strainer Flange Gasket	2	70-0065
20	Flange Bolt	2	70-0054
21	Flange Nut	2	70-0055
22	Flange 1/4" FPT	1	70-0024
23	Flange 1/2" FPT (Standard) SW, WN, ODS Available	1	70-0023

### WELD END DIMENSIONS 5" & 6"

PORT SIZE	A	T
5" (125 mm)	5.05" (128 mm)	0.26" (6.6 mm)
6" (150 mm)	6.06" (154 mm)	0.28" (7.1 mm)

A DIA

## SERVICE AND MAINTENANCE

**Failure to close:** The pilot solenoid valve is not opening due to an electrical problem. Disc strainer or high pressure pilot line may be plugged. Pilot pressure source is not high enough; it must be at least 10 psi (0.7 bar) above pressure through main valve. Manual opening stem is turned in. Dirt may be lodged between the piston/seat and valve piston wall.

**Failure to open:** The pilot solenoid valve is jammed open with dirt. Pilot solenoid valve manual opening stem is turned in. Pilot pressure and pressure through main valve are not equalizing. Check for reverse installation of main valve preventing pressure above piston/seat from bleeding down to outlet of main valve. Dirt may be lodged between piston/seat and valve piston wall. The opening spring may be damaged or broken.

**Manual operation:** If it is necessary to manually hold open the HCK2 valve, cautiously remove the seal cap and turn the manual opening stem inward (clockwise) as far as possible. The piston/seat should now be mechanically held open, and valve will not close until the manual opening stem is turned out (counter-clockwise). Do not operate the HCK2 automatically when the manual opening stem is turned in or else stem may break after repeated cycles.

**Loss of power:** If the HCK2 pilot solenoid is de-energized, the HCK2 will open. If this must be avoided during mid-defrost of large evaporators, merely use a normally open pilot solenoid valve. As an alternate, a unique HCK5 model is available which stays closed until the system pressure equalizes if the pilot solenoid loses electric supply.

**Disassembly:** If it is necessary to remove or disassemble valve for servicing, be sure the high pressure pilot line and main valve are completely isolated from the refrigeration system and all refrigerant is removed (pumped out to zero pressure). Be sure to follow refrigeration system safe procedures. Disconnect pilot line, clean or replace disc strainer/orifice assembly as necessary.

To inspect valve interior, after removing pressure, slowly loosen the cover bolts equally (or screwed cover of 1 1/4" HCK2) and break gasket seal, being careful to avoid any refrigerant which may still remain. Remove cover bolts and cover. Remove piston/seat. If necessary, a cover bolt can be screwed into center of piston/seat to lift it from valve body; use 3/8"-16 bolt for 1 1/4" piston/seat. Clean and inspect for burrs and damage to seating surfaces. Slight marks and burrs can often be removed with emery paper by hand or power lapping. Damaged parts should be replaced. When replacing piston/seat in field, for maximum valve tightness it is advisable to lap the seat into the valve body. Lightly lubricate main valve interior bore with refrigerant oil and install spring and piston/seat. Manually simulate valve operation by pushing on top of piston/seat. Action should be smooth and spring should readily push piston/seat back; if not, polish the bore and piston with emery cloth and check the spring for position and integrity. Re-assemble cover, gasket and bolts, pilot line and disc strainer. Carefully check the entire valve for leaks before restoring the valve to service.

**Opening shock (at the conclusion of defrost):** To minimize this sudden drop in pressure and possible evaporator exit slugs of liquid, bleed down evaporator pressure with a small equalize solenoid (bypass) valve before de-energizing the pilot solenoid valve to open the HCK2, see below. Alternately use the lowest possible defrost pressure by properly setting the defrost relief regulator and controlling incoming high pressure gas (hot gas).

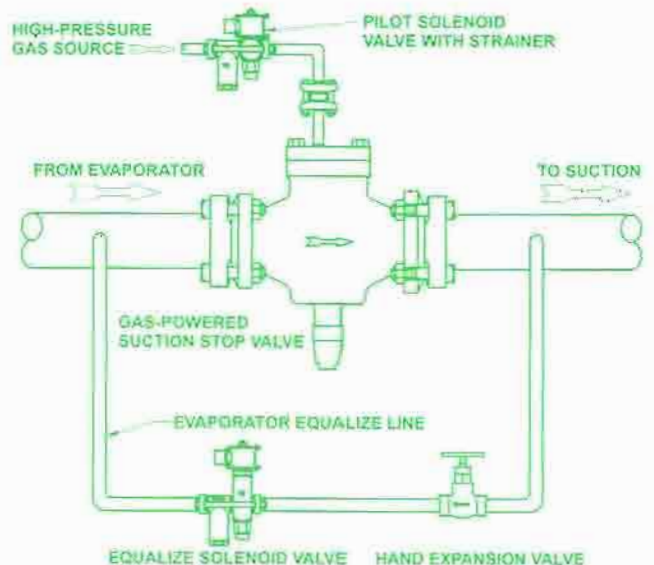

## CAUTION

Hansen valves are only for refrigeration systems. These instructions and related safety precautions must be completely read and understood before selecting, using, or servicing these valves. Only knowledgeable, trained refrigeration mechanics should install, operate, or service these valves. Stated temperature and pressure limits should not be exceeded. Valve cover or pilot line should not be removed from valves unless system has been evacuated to zero pressure. See also Safety Precautions in current List Price Bulletin and Safety Precautions Sheet supplied with product. Escaping refrigerant might cause personal injury, particularly to the eyes and lungs.

## WARRANTY

Hansen valves are guaranteed against defective materials or workmanship for one year F.O.B. our plant. No consequential damages or field labor is included.

## TYPICAL APPLICATION

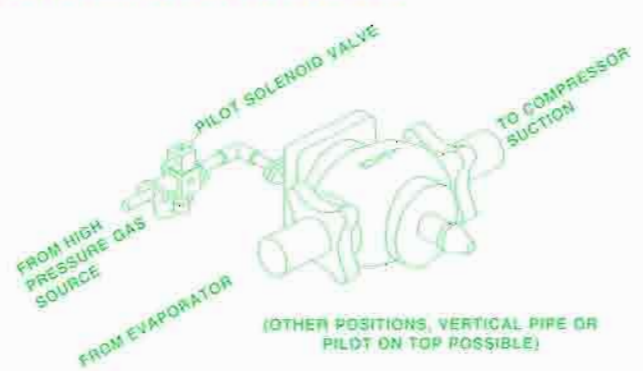

## DEFROST CONTROL

Control of the entire defrost process of large, low temperature evaporators, including those using HCK2 Gas-Powered Suction Stop Valves is ideally accomplished by the use of a Hansen Frost Master® or Frost Master® Plus Defrost Controller. In general, the Frost Master® is able to reduce the amount of cold liquid in the coil at the start of defrost, reduce the initial shock of hot gas entry (soft gas), efficiently terminate hot gas stage and to permit the evaporator to return to low pressure with minimum shock to the system and its piping and evaporator.

### Frost Master® Plus

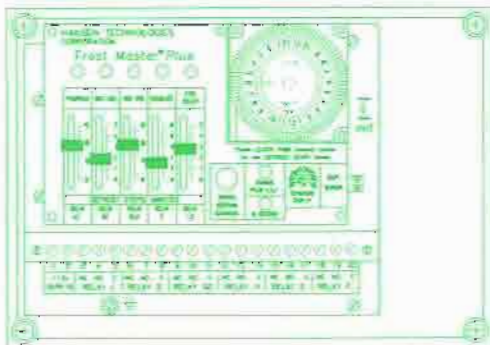

Teflon® is a registered trademark of DuPont

## ORDERING INFORMATION

PORT SIZE (mm)	FLANGE CONNECTION STYLES & SIZE		
	SW, WN, FPT		ODS
	STD	ALSO	STD
1 1/2" (32)	1 1/2"	1", 3/4"	1 1/2"
1 1/2" (40)	1 1/2"	2"	1 1/2"
2" (50)	2"	1 1/2"	2 1/2"
2 1/2" (65)	2 1/2"	3"	2 1/2"
3" (80)	3"	—	3 1/2"
4" (100)	4"	—	4 1/2"
5" * (125)	5" BW	—	—
6" * (150)	6" BW	—	—

\* 5" & 6" are integral butt weld only, Type HCK2W.

**TO ORDER:** Specify type HCK2, port size, flange connection style and size, and pilot solenoid valve if desired. For pilot solenoid valve: specify HS6 for 2" and smaller HCK2, or HS8 for 2 1/2" and larger; connection style and size: 1/2" FPT standard, SW or WN available; voltages: 115V, 230V, 24V; 50/60Hz. Unless otherwise specified standard coil with 1/2" fitting for conduit will be supplied with pilot valve. Also available, DIN plug coil for grounded cord connection or coil with junction box.

## TYPICAL SPECIFICATIONS

"Gas-powered suction stop valves shall be normally open, remote pilot pressure operated, with manual opening stem, pilot line disc strainer and suitable for a safe working pressure of 400 PSIG (27 bar), as manufactured by Hansen Technologies Corporation or approved equal."

## OTHER PRODUCTS

- Ammonia Pressure-Relief Valves
- Rupture Disc Assemblies
- Gauge, Purge, and Needle Valves
- Shut-off Valves
- Expansion Valves (Regulators)
- Refrigerant Solenoid Valves
- Refrigerant Pressure Regulators
- Small Pressure Regulators
- Refrigerant Check Valves
- Strainers
- Gas-Powered Valves
- Refrigerant Float Switches
- Float Regulators (High Side)
- Refrigerant Liquid Pumps
- AUTO-PURGER® Non-condensable Gas Purger
- Vari-Level® Adjustable Level Controls
- Techni-Level® Transducer Probes
- Frost Master® Defrost Controllers
- SEE-LEVEL® Refrigerant Liquid Indicators

## HANSEN TECHNOLOGIES CORPORATION

6827 High Grove Boulevard  
Burr Ridge, Illinois 60521 U.S.A.  
Telephone: (630) 325-1565  
Toll-free: 1-800-426-7368  
FAX: (630) 325-1572  
E-mail: info@hantech.com  
Web Site: www.hantech.com