

HANSEN TECHNOLOGIES CORPORATION



2" Constant Flow Regulator: HFC60N

Specifications, Applications, Service Instructions & Parts

HFC CONSTANT FLOW REGULATORS

Flanged
FPT, SW, WN & ODS
for refrigerants



INTRODUCTION

These carefully designed and manufactured constant flow regulators accurately control the flow rate from refrigerant liquid pumps. They will modulate to maintain a pre-calibrated ideal constant flow of refrigerant independent of pressure changes. A properly selected flow regulator can minimize the tendency to operate in a high NPSH pump region and consequently cavitate and thus possibly lose prime and cease pumping.

In refrigeration overfeed systems with multiple evaporators, the flow volume of the recirculation pump will vary with the number of rooms or evaporators. Flow volume is also varied by the number of liquid makeup solenoid valves open and evaporators being cycled for room activity, temperature control, or defrost. The use of constant flow regulators not only stabilizes the pump output, but also helps to provide a more consistent liquid supply flow and pressure to the refrigeration system under these variable conditions.

APPLICATION

These regulators are specifically designed for refrigeration systems. They are suitable for ammonia, R22, R134a and other approved refrigerants. While primarily intended to be installed at the outlet of refrigerant liquid pumps, these versatile regulators can be used to control flow to individual circuits of large evaporators in place of hand expansion valves or other balancing devices in liquid overfeed systems.

KEY FEATURES

These regulators enable pumps to safely function in a range not normally available to pumps using discharge orifices. This means higher available pumping head and greater flow rates while still protecting against cavitation and motor overload. The typical pump curve below illustrates the additional operating range available using a flow regulator in lieu of a discharge (Q-max) orifice. Also, it may be possible for a smaller capacity (less expensive) pump to be used where it otherwise would not have been practical.

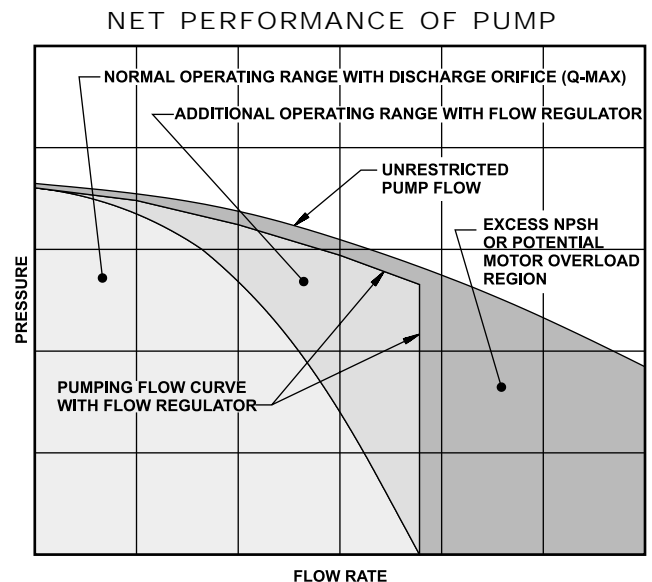

MATERIAL SPECIFICATIONS

Body: Ductile iron, ASTM A536 (65,000 psi tensile)
(nodular iron, GGG-40)

Cover: Steel

Piston: Steel, disc type

Gaskets: Non-asbestos, graphite composite

Flanges: Forged steel, ASTM A105

Constant Flow Control Range:

Ammonia: 4 to 40 psid (0.3 to 2.7 bar)

Halocarbons: 8 to 80 psid (0.5 to 5.5 bar)

Safe Working Pressure: 400 psig (27 bar)

Operating Temperature: -60 to +240F (-50 to +115°C)
(Lower temperatures at pressure down-ratings)

ADVANTAGES

Hansen Constant Flow Regulators offer a simple and reliable solution for stabilizing flow from refrigerant liquid pumps to the plant. Properly selected, these tamper resistant regulators enable pumps to operate closer to their unrestricted pump flow curve but not to exceed the calibrated quantity of flow. They will prevent a pump from operating in a region which exceeds its motor horsepower rating and required NPSH (Net Positive Suction Head). Furthermore, by providing a consistent liquid supply pressure to evaporator expansion devices, more predictable refrigerating results can occur.

Standard models specifically match the capacities and motor ratings of Hansen Hermetic liquid pumps. Selection assistance is available for other pumps.

INSTALLATION DIMENSIONS

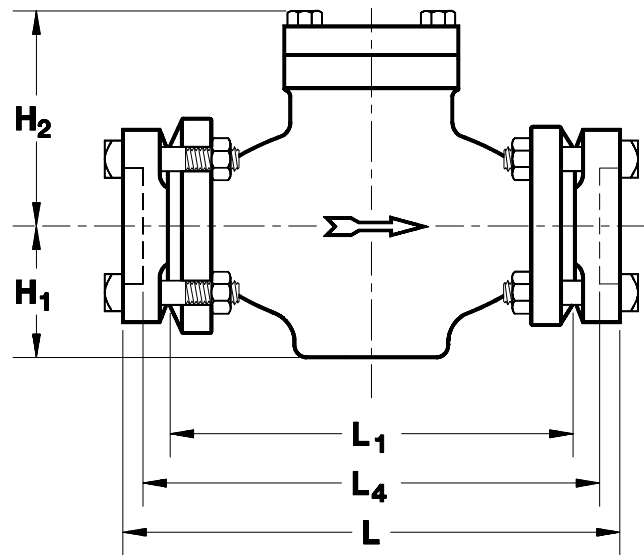

Size (mm)	H1	H2	L		L1	L4	W
			FPT, SW	WN, ODS			
1" (25)	1.39" (35)	4.33 (110)	8.20" (208)	8.94" (227)	6.19" (157)	7.20" (183)	4.63" (118)
2" (50)	3.47" (88)	5.14" (131)	12.39" (315)	13.39" (340)	9.88" (251)	10.89" (277)	4.50" (114)
2½" (65)	3.71" (94)	6.06" (154)	13.01" (330)	14.03" (356)	9.88" (251)	11.01" (280)	5.62" (143)

*Maximum width of valve.

TYPICAL APPLICATION

(See also Pump Bulletin HP237)

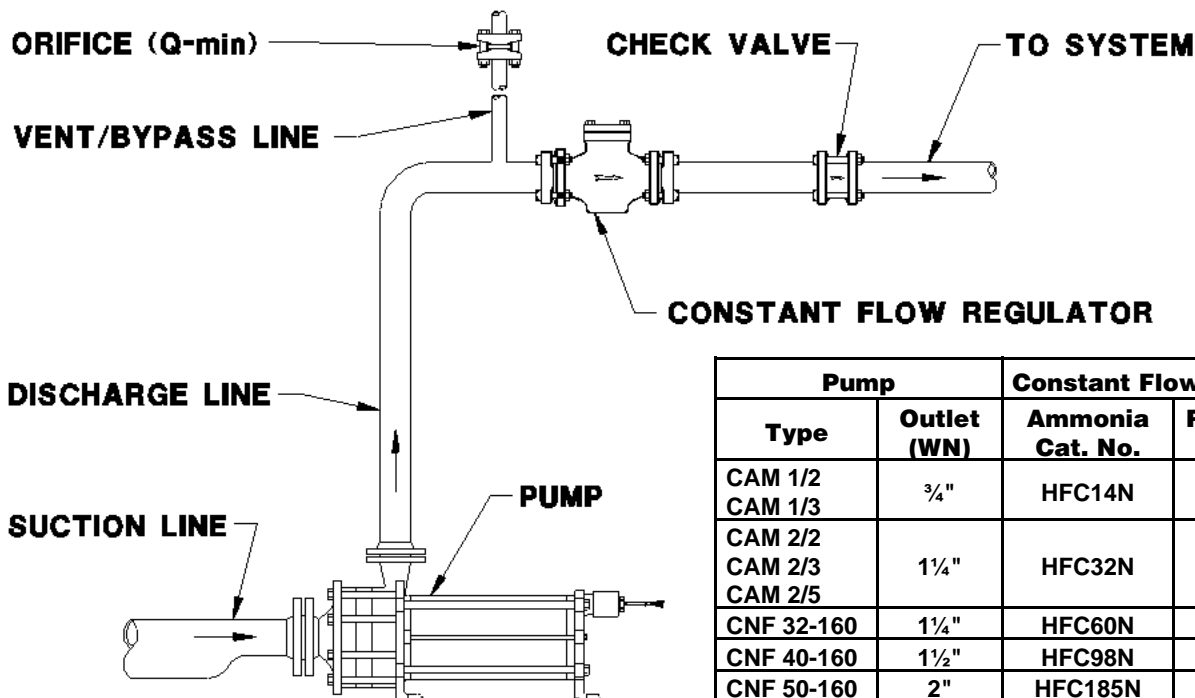

Pump		Constant Flow Regulator	
Type	Outlet (WN)	Ammonia Cat. No.	R22, R134a Cat. No.
CAM 1/2 CAM 1/3	¾"	HFC14N	HFC14F
CAM 2/2 CAM 2/3 CAM 2/5	1¼"	HFC32N	HFC32F
CNF 32-160	1¼"	HFC60N	--
CNF 40-160	1½"	HFC98N	HFC95F
CNF 50-160	2"	HFC185N	HFC175F

INSTALLATION

Protect the interior of the regulator from dirt and moisture during storage and installation. System should be free from dirt, weld slag, and rust particles. Constant flow regulators should be installed near the pump outlet after the vent/bypass line and before the check valves, see Typical Application section on page 2. Flow regulators must be installed only in the discharge line from the pump because any pressure drop device or even a strainer in the pump suction line could cause bubbles to form and enter the pump to create cavitation and resultant pump damage or loss of flow. Install regulators with arrow on body in the direction of normal refrigerant flow. Flow regulators will not prevent reverse flow; use check valves where necessary. When possible, mount regulators in an upright position in horizontal lines. Regulators can however be mounted on their side or in vertical lines. For proper flange gasket sealing, care must be taken when threading or welding to assure flanges are parallel to each other and perpendicular to pipe. Also, gaskets should be lightly oiled, and all bolts must be tightened evenly.

Welds should be annealed as necessary in accordance with good practice. Supplementary painting of regulators, valves, piping, and welds is recommended for complete corrosion protection. Pipe covering, where applied, should have proper moisture barrier. Before putting regulators into service, all pipe connections and components should be tested for leaks at pressure levels called for in appropriate codes.

SERVICE AND MAINTENANCE

These constant flow regulators do not require any field adjustments. If regulator does not seem to be functioning properly, as possibly indicated by erratic flow or unusual noises, an inspection of the internal parts may be advisable.

When it is necessary to remove or disassemble the regulator for servicing, be sure it is completely isolated from the refrigeration system and all refrigerant is removed (pumped out to zero pressure). Be sure to follow refrigeration system safety procedures and read the Caution section in this bulletin. To inspect regulator interior, slowly loosen the four cover bolts equally (or the screwed cover of the 1" regulator) and break the gasket seal, being careful to avoid any refrigerant which may still remain. Remove the piston and spring. If necessary, insert a 1/4"-20 screw into the center of 1" piston to retrieve; use a cover bolt for 2" piston. Clean and inspect parts for damage to machined surfaces. Slight marks and burrs can often be removed with emery paper by hand or power lapping. Damaged parts should be replaced. Lightly lubricate main interior bore with refrigerant oil before installing piston and spring as indicated in parts list. Manually simulate regulator operation by pushing on top of piston; action should be smooth. Replace cover, gasket, and bolts. Carefully check the entire regulator for leaks before restoring it to service.

PARTS LIST 1"

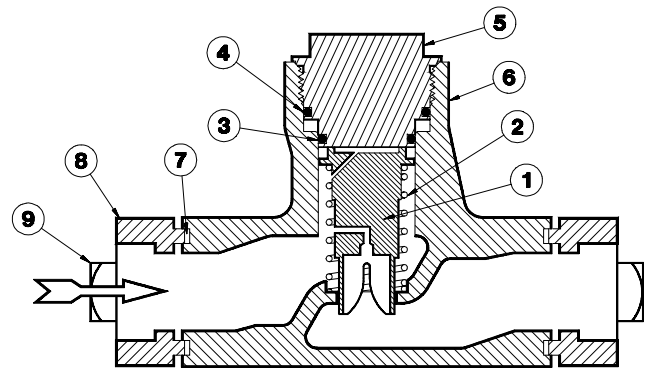

Item	Description	Qty.	Part No.
1	Piston	1	FACTORY
2	Spring	1	FACTORY
3	Cover O-Ring, Lower	1	70-0130
4	Cover O-Ring, Upper	1	70-0131
5	Cover	1	70-0307
6	Body, 1"	1	61-0329
7	Flange Gasket	2	70-0132
8	Flange (Various)	2	FACTORY
9	Flange Bolt (5/8"-11x2.75")	4	70-0339
10	Flange Nut (5/8"-11)	4	70-0136

PARTS LIST 2", 2½"

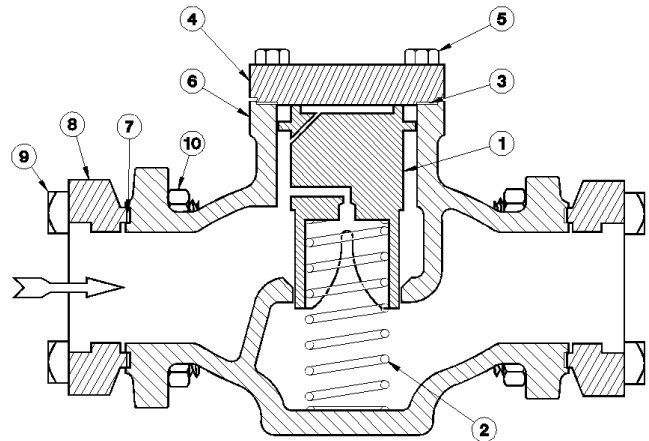

Item	Description	Qty.	Part No.
1	Piston	1	FACTORY
2	Spring	1	FACTORY
3a	Cover Gasket, 2"	1	75-0196
3b	Cover Gasket, 2½"	1	75-0128
4a	Cover, 2"	1	75-0107
4b	Cover, 2½"	1	75-0121
5a	Cover Bolt, 2"	4	75-0175
5b	Cover Bolt, 2½"	4	65-0057
6a	Body, 2"	1	61-0362
6b	Body, 2½"	1	61-0375
7a	Flange Gasket, 2"	2	75-0138
7b	Flange Gasket, 2½"	2	75-0125
8	Flange (Various)	2	FACTORY
9a	Flange Bolt, 2" (5/8"-11x3.25")	8	70-0135
9b	Flange Bolt, 2½" (3/4"-10x3.75")	8	75-0202
10a	Flange Nut, 2" (5/8"-11)	8	70-0136
10b	Flange Nut, 2½" (3/4"-10)	8	75-0210

PRINCIPLES OF OPERATION

These constant flow regulators are, in essence, a variable orifice whose flow area changes directly with the pressure drop (ΔP) across it. Regulators have both a characterized variable orifice and a fixed orifice. These orifices on a typical piston are shown below where the shaded area represents an opening from the inlet side (P1) to the outlet side (P2) of the regulator. When flow first begins ($\Delta P < \text{Control Range}$), the regulator is wide open, and liquid flows freely through both orifice areas. As the pressure drop increases into the control range of the regulator ($\Delta P = \text{Control Range}$), the piston acting against the spring force begins to move the variable orifice area more closed. The piston will continue to modulate and maintain a given calibrated flow rate within the control range. Once beyond the control range ($\Delta P > \text{Control Range}$), the variable orifice area will be completely closed, and the fixed orifice area will provide a flow path so as not to completely shut off the regulator.

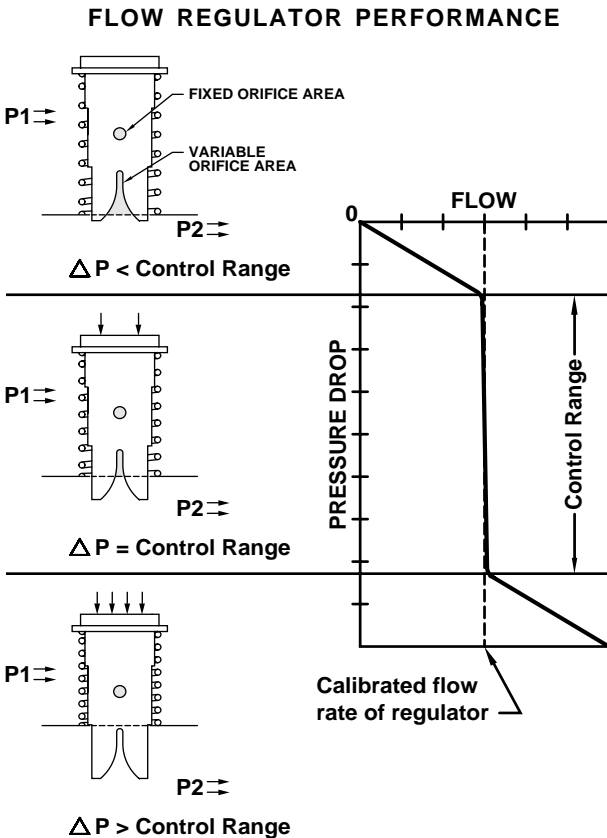

Constant Flow Control Range:
 Ammonia= 4 to 40 psid (0.3 to 2.7 bar)
 R22, R134a= 8 to 80 psid (0.5 to 5.5 bar)

CONVERSIONS

1 psi = 0.06895 bar = 6.895 kPa
 1 U.S. Gallon = 0.8327 Imperial Gallons = 3.7854 liters
 1 U.S. GPM (gallons per minute) = 0.06309 dm³/s
 (or L/s) = 0.227124 m³/h

CAUTION

Hansen constant flow regulators are only for refrigeration systems. These instructions and related safety precautions must be read completely and understood before selecting, using, or servicing these regulators. Only knowledgeable, trained refrigeration mechanics should install or service these regulators. Stated temperature and pressure limits should not be exceeded. See also safety precautions in current List Price Bulletin and Safety Precautions sheet supplied with product. Escaping refrigerant might cause personal injury, particularly to the eyes and lungs.

WARRANTY

Hansen constant flow regulators are guaranteed against defective materials and workmanship for one year F.O.B. factory. No consequential damages or field labor is included.

ORDERING INFORMATION

For Use With Ammonia Refrigerant (R717)				
Flow Regulator Cat. No.	Size (mm)	Flow		Standard Connection
		GPM	m ³ /h	
HFC14N	1" (25)	14	3.18	¾" FPT
HFC32N	1" (25)	32	7.27	1¼" SW
HFC60N	2" (50)	60	13.64	1½" SW
HFC98N	2" (50)	98	22.27	2" SW
HFC185N	2½" (65)	185	42.05	2½" SW

For Use With Halocarbon Refrigerant (R22, R134a & Other Approved)				
Flow Regulator Cat. No.	Size (mm)	Flow		Standard Connection
		GPM	m ³ /h	
HFC14F	1" (25)	14	3.18	¾" FPT
HFC32F	1" (25)	32	7.27	1¼" SW
HFC95F	2" (50)	95	21.59	2" SW
HFC175F	2½" (65)	175	39.77	2½" SW

TO ORDER: Specify catalog number, refrigerant, GPM requirements, pumping head or pressure differential and connection style (SW, WN, FPT, ODS) and size.

TYPICAL SPECIFICATIONS

"Refrigerant constant flow regulators shall be flanged, ductile iron bodied, spring loaded, accurately factory set, having disc type pistons and suitable for a Safe Working Pressure (SWP) of 400 psig (27 bar), as manufactured by Hansen Technologies Corporation or approved equal."

HANSEN TECHNOLOGIES CORPORATION

6827 High Grove Boulevard
 Burr Ridge, Illinois 60527 U.S.A.
 Telephone: (708) 325-1565
 Toll-free: 1-800-426-7368
 FAX: (708) 325-1572