

HANSEN TECHNOLOGIES CORPORATION



Rupture Disc Assemblies with Pressure Gauges Shown Installed Between a 3-way Valve and Two Pressure Relief Valves

INTRODUCTION

Hansen rupture disc assemblies (RDAs) are used to indicate which pressure-relief valve has discharged. A pressure-relief valve will reseat after discharging. However, a rupture disc remains open after bursting. An installed pressure gauge or switch (required by code) provides a visual or electronic indication that the rupture disc has burst. Also, rupture disc assemblies provide a metallic seal to eliminate any possibility of minute losses of refrigerant via pressure-relief valve seat materials.

Hansen rupture disc assemblies are designed with a double-weld construction. There are no gaskets to leak. The rupture disc inside the assembly is hermetically welded to the body and mechanically isolated from any pipe stress. This eliminates both internal and external leaks and ensures that the disc will burst at its design pressure.

KEY FEATURES

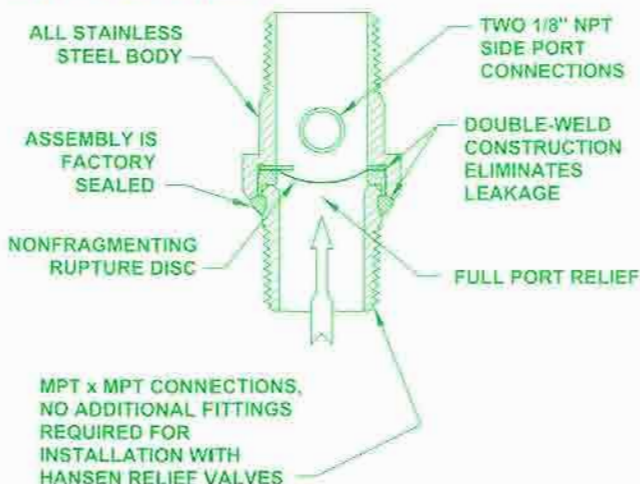

Specifications, Applications, Service Instructions & Parts

Rupture Disc Assemblies

For Industrial Ammonia and
Industrial and Large
Commercial Halocarbon
Refrigeration Systems

TYPICAL APPLICATION

These rupture disc assemblies are typically used between a vessel (or 3-way valve) and a pressure-relief valve. They must be used for atmospheric, not differential, pressure relief. In limited situations where a complete loss of refrigerant charge is safe and both environmentally and economically acceptable, rupture disc assemblies can be used without a pressure-relief valve. These rupture disc assemblies are required when using Hansen pressure-relief valves for halocarbon applications.

ASME RULES

In accordance with ASME code, a pressure gauge or a pressure switch must be connected to the space between the rupture disc and the connected pressure-relief valve. Two 1/8" NPT side ports are provided in Hansen's rupture disc assemblies for this purpose.

When a rupture disc assembly is installed with a pressure-relief valve, the stamped capacity of the pressure-relief valve must be multiplied by .9 (90%).

SPECIFICATIONS

Body: Stainless Steel
Rupture disc: Nickel
Refrigerant temperature: -60°F/-51°C to 240°F/115°C
Disc ambient temperature: Between 32°F/0°C and 125°F/52°C the nominal burst pressure is within 2% of the pressure stamped on the rupture disc assembly body. At lower temperatures, the burst pressure will be slightly higher. Contact Hansen Technologies directly for specific applications.
Safe working pressure (body): 400 psig/27 bar
For ammonia, R22, R134a, and other Hansen-approved refrigerants

INSTALLATION

When installing these rupture disc assemblies, ensure that the threads are clean. If Teflon tape, pipe dope, or other thread sealer is used, be certain that none gets inside the rupture disc assembly or connected pressure-relief valve.

Make sure that the rupture disc assembly is installed in the proper direction. The arrow stamped on the body of the rupture disc assembly should point in the direction of flow, from the vessel to the pressure-relief valve. This ensures that the disc will burst at its design pressure and ensures proper operation of the pressure gauge and switch.

Make certain that the rupture disc assembly is installed tightly. Check for leaks before placing the assembly in service.

IMPORTANT

Do not touch the internal rupture disc with tools, fingers, or other items. Also, the rupture disc will not burst at its design pressure if back pressure builds downstream of the disc.

There are no user-serviceable parts in the rupture disc assembly, pressure gauge, or pressure switch. The rupture disc assembly is a one-time-use item and must be replaced as soon as possible after the disc bursts. Pressure switches and gauges can be reused after verifying proper operation.

These rupture disc assemblies, pressure switches, and pressure gauges are not for liquid applications.

INSTALLATION DIMENSIONS

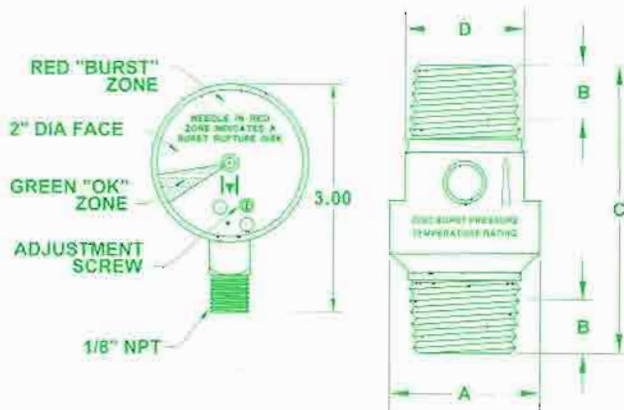

Cat. No.	Connection Size (MPT x MPT) NPT Taper	Dimension			
		A	B (Typical Thread Eng'mt)	C	D (Wrench Flats)
RDA1	1/2" x 1/2"	1.40" 36 mm	.53" 13 mm	2.67" 68 mm	1 1/8" 28 mm
RDA2	3/4" x 3/4"	1.40" 36 mm	.55" 14 mm	2.67" 68 mm	1 1/8" 28 mm
RDA4	1" x 1"	2.23" 57 mm	.66" 17 mm	4.30" 109 mm	1 3/4" 46 mm
RDA5	1 1/4" x 1 1/4"	2.23" 57 mm	.68" 17 mm	4.30" 109 mm	1 3/4" 46 mm

CAUTION

Hansen rupture disc assemblies (RDAs) are for refrigeration systems only. These instructions and related safety precautions must be read completely and understood before selecting, using, or servicing these RDAs. Only knowledgeable, trained refrigeration technicians should install, operate, or service these RDAs. Stated temperature and pressure limits should not be exceeded. Components should not be removed from the system or the system opened unless the system has been evacuated to zero pressure. See also Safety Precautions in the current List Price Bulletin and the Safety Precautions Sheet supplied with this product. Escaping refrigerant can cause injury, especially to the eyes and lungs.

WARRANTY

Rupture disc assemblies are guaranteed for one year F.O.B. our plant. No consequential damages or field labor is included.

OPTIONS

Pressure Gauges. These special gauges are designed specifically for use with Hansen rupture disc assemblies. The 2" diameter face has an easy-to-read "OK/burst" display. The green "OK" range is from 0 to 15 psi. The ambient temperature range for these gauges is +32°F/0°C to +125°F/+52°C and they have a safe working pressure of 400 psig/27 bar. Contact Hansen for applications below +32°F/0°C ambient temperature.

Pressure Switches. These normally open switches close when 10 psi of pressure is sensed. These switches are rated for 15 amps at 6 VDC to 0.5 amps at 240 VAC. The ambient temperature range for these switches is from -20°F/-29°C to +125°F/+52°C and they have a safe working pressure of 400 psig/27 bar.

Note: ASME code requires that a pressure gauge and/or a pressure switch be installed in the space between the rupture disc and the pressure-relief valve. These switches and gauges, when installed in the 1/8" FPT side port, meet this requirement.

ORDERING INFORMATION

Cat. No.	Connection Size MPT x MPT	Pressure Setting
RDA1	1/2" x 1/2"	150, 250, or 300 psi*
RDA2	3/4" x 3/4"	150, 250, or 300 psi*
RDA4	1" x 1"	150, 250, or 300 psi*
RDA5	1 1/4" x 1 1/4"	150, 250, or 300 psi*

*For pressure settings in bar, contact Hansen directly.

To Order: Specify catalog number, pressure setting, and pressure gauge or switch. A pressure gauge or switch is required by code.

HANSEN TECHNOLOGIES CORPORATION

6827 High Grove Boulevard
Burr Ridge, Illinois 60521 USA

Telephone: (630) 325-1565

Toll-free: 1-800-426-7368 E-mail: info@hantech.com

FAX: (630) 325-1572

Web: www.hantech.com