



**WLT
WIRE LEVEL
TRANSDUCER
SENSOR**

INTRODUCTION

Hansen Level Transducer Sensors are reliable, well engineered electronic level monitoring devices. They provide a computer compatible 4-20 mA (milliamp) output signal proportional to liquid level. The sensor consists of a compact, electronic transmitter in a watertight housing assembled on top of a rugged mechanical base. The wire element is an insulated stainless-steel wire and can be mounted directly in a level column. If it needs to be installed in a vessel, then an inner pipe is required. Typical applications include: vertical vessels, pilot receivers and pump accumulators. These sensors are intended to be operating control devices and should never be used as safety devices. The sensor can be installed in refrigeration systems and similar demanding applications with high pressure fluids. All versions emit a 4-20mA analog signal via the M12 connector and field cable.

There are two different versions of transducer sensors.

WLT: 2-wire Level Transducer Sensor

WLT-C: 3-wire Level Transducer Sensor with integrated Motorized Valve (MCV) controller.

This bulletin will cover the WLT which can be used for new installations, direct VLT replacement, and replacement of the LP probe using an emulator (LPE). For LP probe replacement instructions, see quick start guide WLT-QSG.

Specifications, Applications, Service Instructions & Parts

WLT WIRE LEVEL TRANSDUCER SENSOR

for use in 4–20 mA control
loops for refrigerant level
control and monitoring

KEY FEATURES

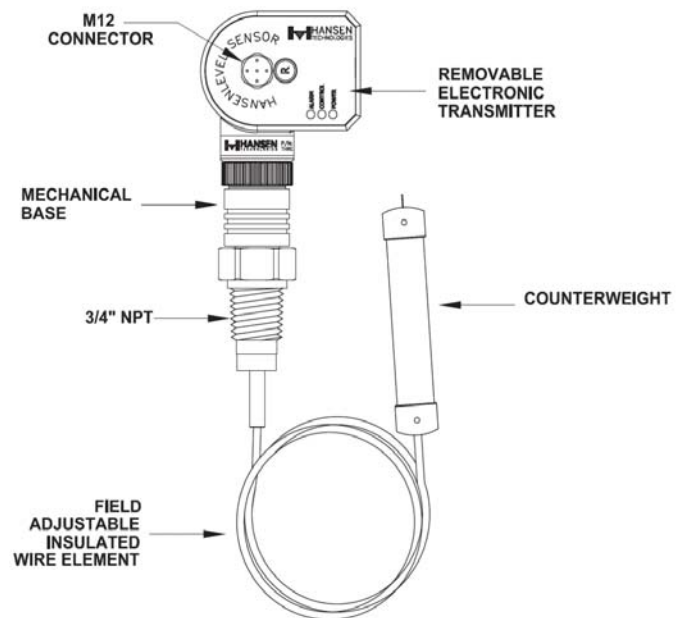

ADDITIONAL FEATURES

- Specifically designed for refrigeration systems.
- Flexible wire element adjustable to length.
- Active length up to 157" (4000mm).
- One transducer sensor fits most legacy probe lengths.
- Compact design minimizes shipping cost.
- Direct replacement for LP, VLT probes.
- Suitable for ammonia and Hansen approved Halocarbons.

MATERIAL SPECIFICATIONS TRANSDUCER SENSOR

Signal Output: 4–20 mA, DC, isolated

Input Power: 24 VDC ± 10%, regulated

Maximum Load Resistance: 500 ohms (1.5W)

Classification: Transmitter type/class 2U ANSI/ISA-S50.1

Enclosure: Watertight NEMA 4 (IP65)

Fitting: ¾" NPT male, connection to Level Column

Wire Adjustable Length: 20" (510 mm) to 157" (4000 mm)

NH3 refrigerant can go down to 12" (305mm)

Safe Working Pressure (SWP): 755 psig (52 bar)

Operating Temperature:

Ambient: –22°F to +122°F (–30°C to +50°C)

Liquid: –76°F to +140°F (–60°C to +60°C)

LEVEL COLUMN

Body: 3" Schedule 40 pipe, standard

Sight Glass: Located at 50% level, standard Safe

Working Pressure (SWP): 400 psig (27 bar) Operating

Temperature: –60°F to +240°F (–50°C to +115°C)

ADVANTAGES

The electronics can be changed without opening the refrigeration system. These sensors have internal dampening to avert false alarms triggered by normal turbulence and splashing of refrigerant. The 4-20mA signal is commonly used with computers, programmable logic controllers, and other accessories.

REMOTE DISPLAY

A milliamp meter or Hansen RDR may be inserted in series with the 4–20mA control loop to facilitate localized indication of the liquid level.

INSTALLATION

Level columns are required in applications where refrigerant evaporation occurs within the vessel being monitored; such as flooded evaporators, low side vessels or accumulators. Using a level column (typically 3" diameter) separates the sensor from the boiling which occurs in the vessel. Therefore, true refrigerant liquid level is being measured, not surges of bubbling liquid. Level columns can be supplied by Hansen or fabricated in the field. See page 12 for level column details and dimensions. When the refrigerant temperature is lower than ambient, the level column must be insulated.

Follow good piping practice and refrigeration system maintenance to avoid oil accumulation inside the level column. Equalizer lines and valves should be positioned as shown in the Level Column Piping Installation diagram on page 3. It is recommended that a high level float switchcutout be installed whenever practical. This provides a nonadjustable safety control in case of an incorrect high level setting or failure of a high level control device.

On halocarbon systems, over a period of time, the refrigerant in the level column will become oil rich. An extremely high concentration of oil may cause the original calibration to become offset, thus causing a false reading of refrigerant level. To prevent this, periodically remove oil from the level column.

INSTALLATION STEPS SUMMARY

See pages 4-5 for more detailed & visual installation steps.

1. Separate the electronic transmitter from the mechanical base.
2. Determine sensor wire length. For replacement of existing probes, lay wire element next to old probe on ground. Match thread connection to end and cut to length.
3. Cut wire element to correct length and attach counterweight.
4. Use the supplied programming cable and the Hansen software tool to configure the sensor basic settings. Connect the sensor based on model wiring diagram.
5. Connect the cable to the electronic transmitter via M12 connector.
6. Install and tighten the mechanical base in the column using non-electrically isolating pipe sealant. Attach the electronic transmitter to the mechanical base.
7. Manually calibrate the sensor if the refrigerant is not listed in the software.
8. Ready to use. Validate output vs actual level in column or vessel.

LEVEL COLUMN PIPING INSTALLATION (SCHEMATIC ONLY, NOT FOR CONSTRUCTION)

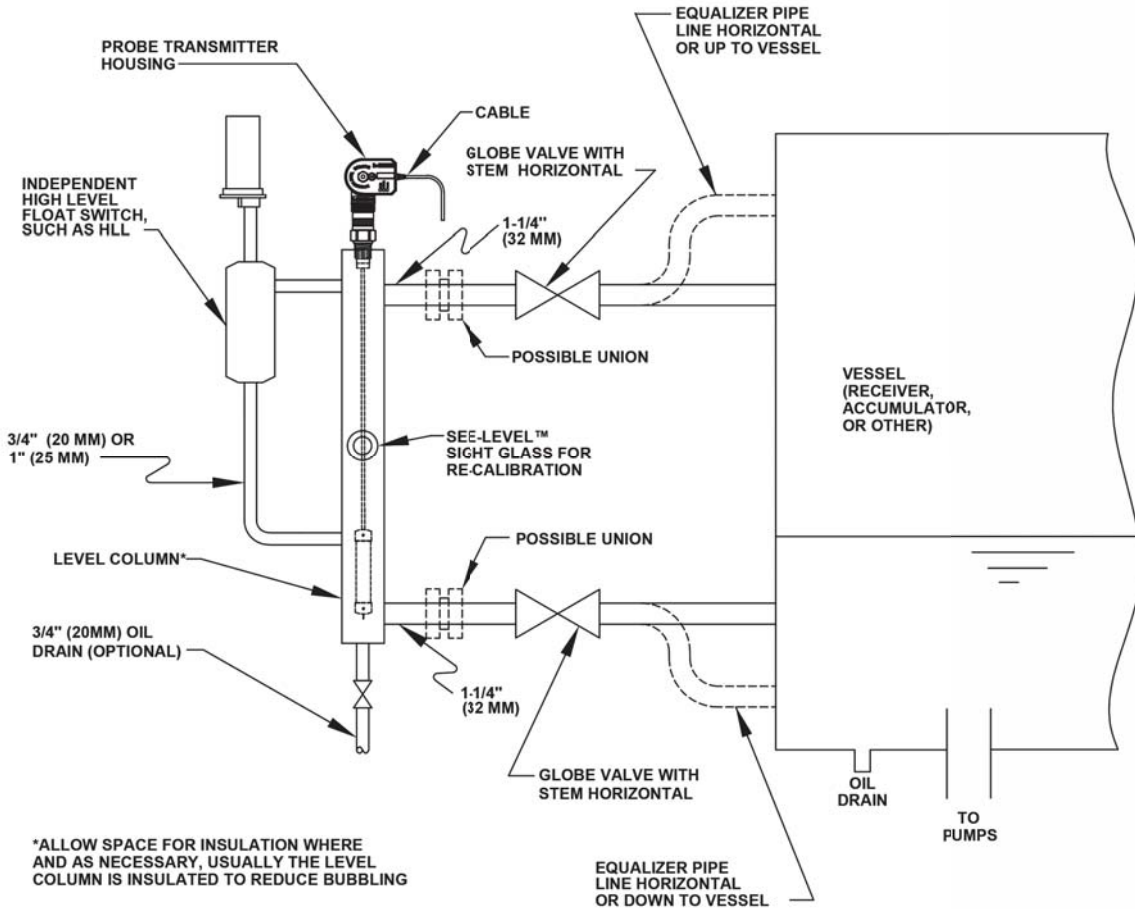

SENSOR CONNECTIONS

WLT: 2-wire sensor with 4-20mA output

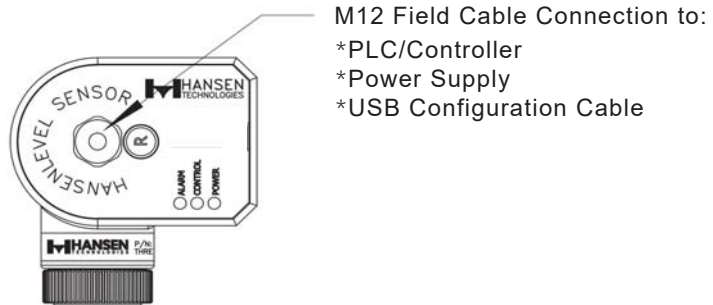

The WLT sensor can provide a signal to a PLC via the M12 connection. An external power supply is wired to the M12 connection to provide voltage to the sensor.

INSTALLATION STEPS

Follow the steps below to install, wire, configure, and use the sensor in a level column. The sensor length is determined by level column height.

1. To adjust the sensor wire, the following items will be needed. The supplied 2.5mm hex key, a wrench, wire cutters, and liquid sealant.



2. Separate the electronic transmitter from the mechanical base.



3. Determine L = Insertion Length

Measure the level column length. Allow for a 2" (50mm) clearance below the tip of the wire to the bottom of the column/tank.

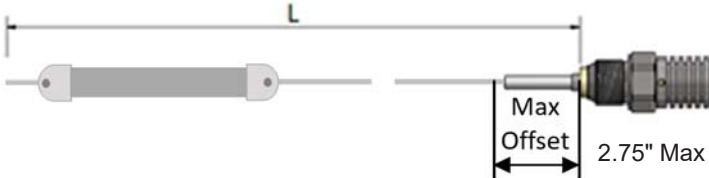

4. Shorten the wire to the appropriate length with a wire cutter.

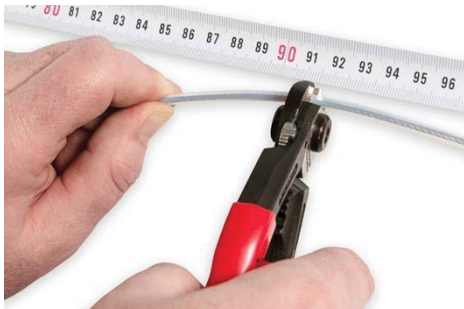

5. Put the wire all the way through the counter-weight until it protrudes (1/4" to 1/2") and tighten (approx range 3.5-4.0 in-lbs) the two set screws with the 2.5mm hex to fix it on the wire. Do not over-tighten the screws. Do not remove the insulation on the wire.

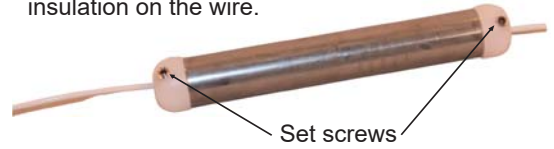

Once the length is determined, the electronic transmitter can be configured.

6. Connect the M12 to USB programming cable to the computer with the Hansen software tool installed. The program is available at (www.hantech.com/product-list/wire-level).



7. Open the Hansen tool and press Start scanning to initiate connection to the sensor. 3 LEDs will display around the M12 connector. Green, red and yellow LEDs will flash when the communication is active.

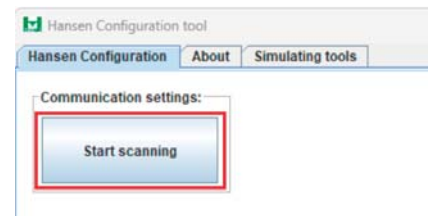

INSTALLATION STEPS - CONTINUED

8. Start the program to configure the Basic settings tab. For the WLT, the Level mode should automatically be detected and the following parameters will need to be populated. See page 8 for additional information and settings.
 - Refrigerant
 - Sensor Length ("L" Dimension determined from Step #3)
 - Level Column (Standpipe) Diameter Size
 - Working Temperature Range
 - Offset Max Level = 2.75" typical (70mm)

Once complete press Save to sensor.

Note: Positioning the cursor over the selections will provide more detailed descriptions.

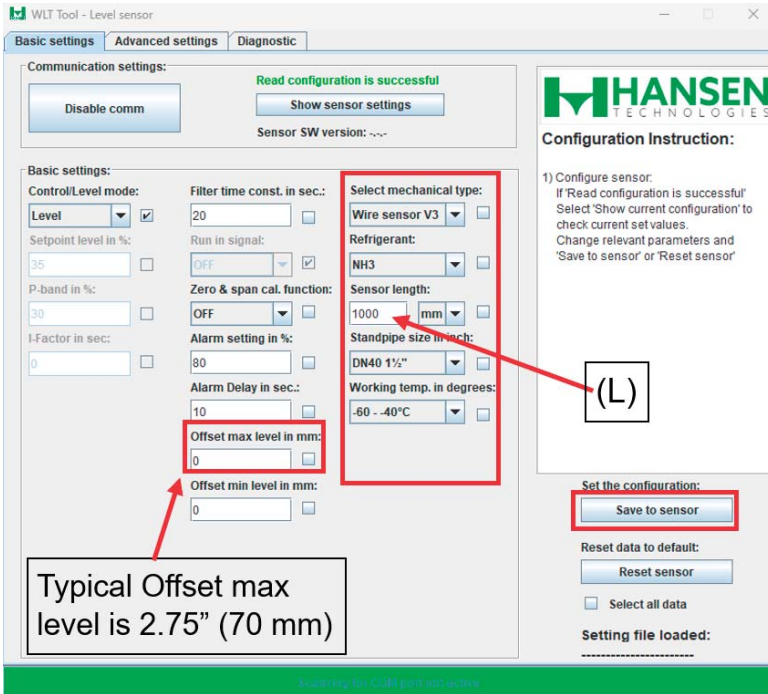

9. Disconnect the programming cable. Connect the 16ft (5m) sensor field cable to the M12 connector on the electronic transmitter. Connect the wires per the diagrams based on the appropriate site configuration. The sensor output is a 4-20mA and is linear to the level.
10. Install and tighten the mechanical base in the level column. Use non-electrically isolating pipe sealant for the 3/4" NPT connection. Do not use Teflon tape.
11. Install and tighten the electronic transmitter to the mechanical base.
12. If the refrigerant is not listed in the software, then manually calibrate (See page 11).
13. Ready for use.

TYPICAL WIRING: NEW INSTALLATIONS

WLT to PLC with Integrated Power Source: 2-wire 4-20mA output

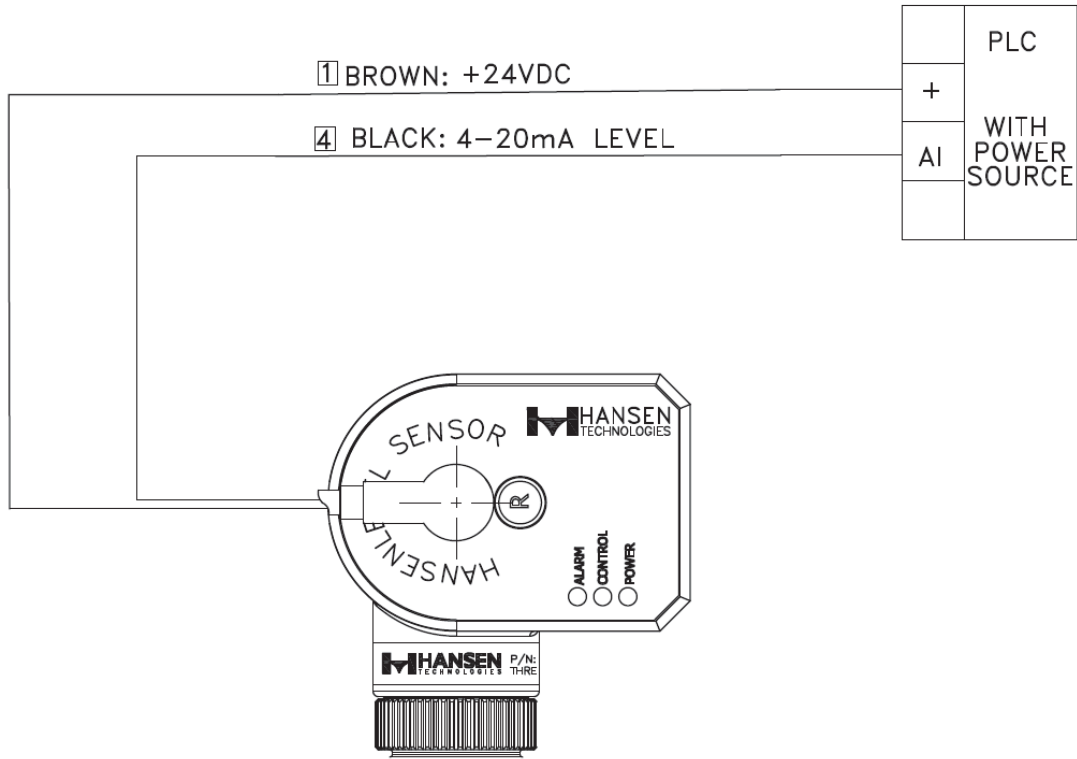

WLT to Controller/PLC with External Power Source: 2-wire 4-20mA output

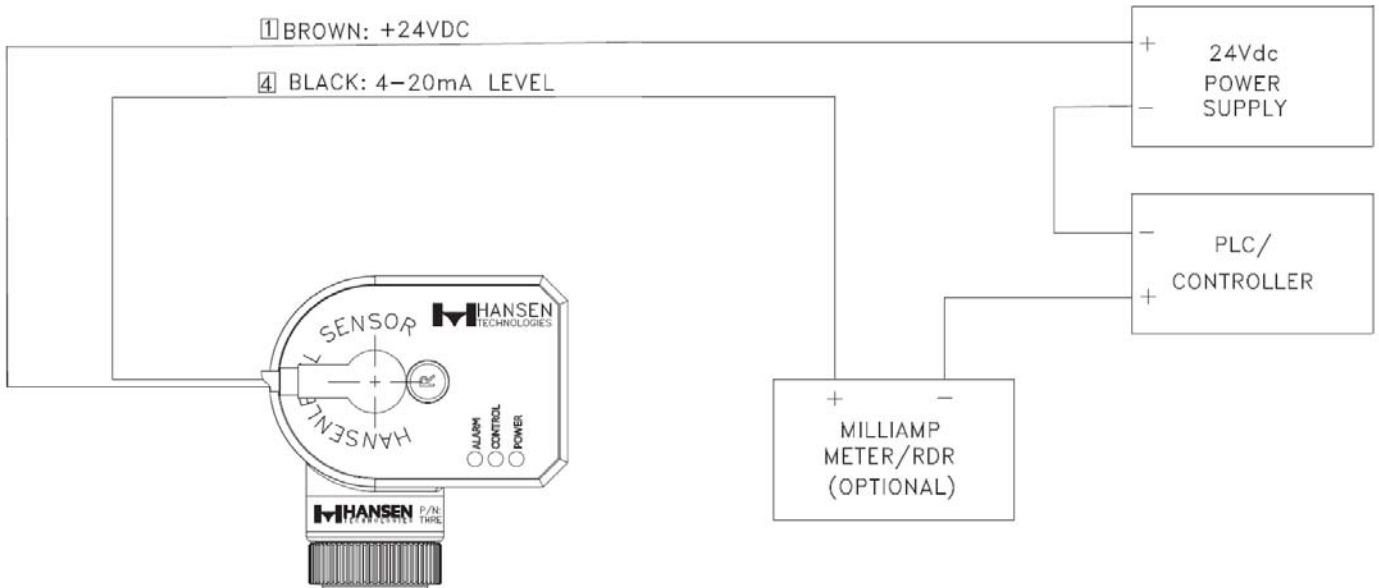

TYPICAL WIRING: HANSEN PROBE REPLACEMENTS

LP Probe Replacement: WLT with LPE Connection to Vari-Level LB Controller: 2-wire 4-20mA output

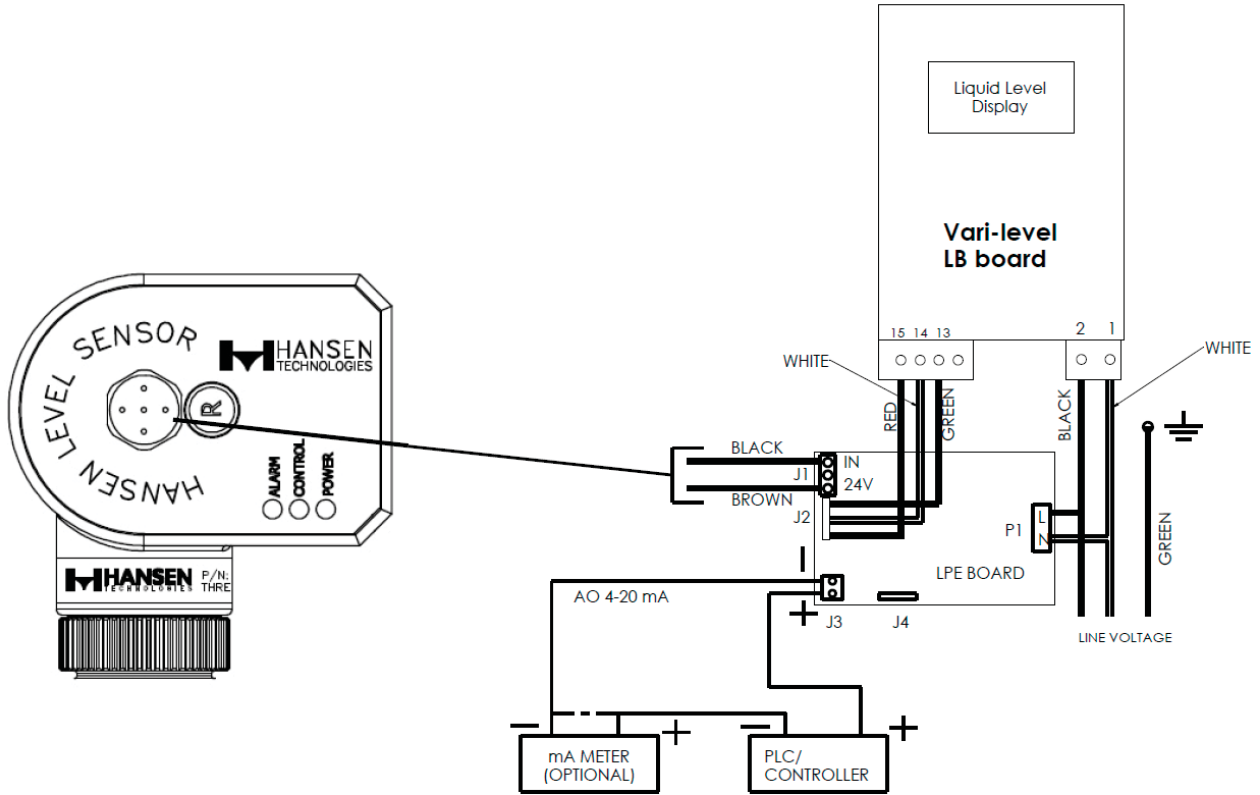

VLT Probe Replacement: WLT with existing VLT wiring: 2-wire 4-20mA output

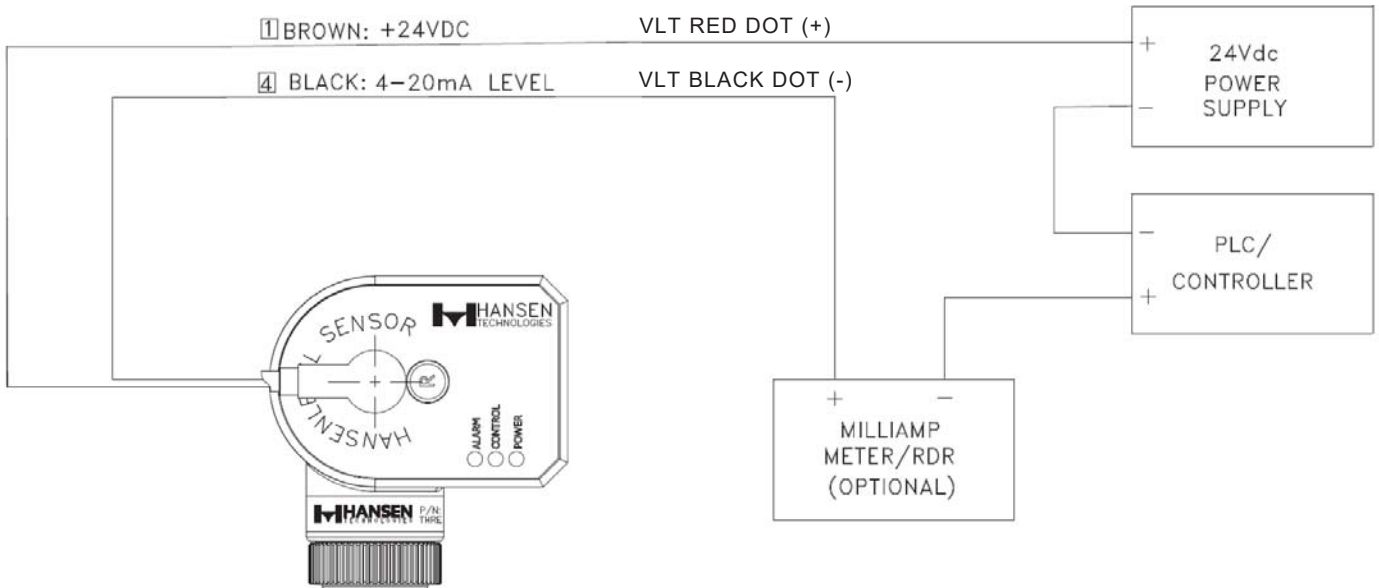

HANSEN SOFTWARE TOOL DETAILS

Software Available on Hansen Website:
www.hantech.com/product-list/wire-level

CONNECTING TO THE SENSOR

The sensor is connected to a laptop using the programming cable which contains a USB connection at one end and the M12 connection at the opposite end. The USB/M12 programming cable is 5ft (1.5m) long. If a longer cable is desired, a 33ft (10m) extender cable (WLT-M12 EXTENSION) is available that connects directly in series with the M12 connector. The laptop will contain the Hansen Configuration tool. The Start scanning button looks for a connected sensor and determines the model. Once detected, the WLT tool application will open 3 LEDs will display around the M12 connector. Green, red and yellow LEDs will flash when the communication is active.



SETTING UP THE SENSOR

The Hansen WLT tool has three configuration tabs: Basic settings, Advanced settings, and Diagnostics/Calibration. The Basic settings screen consists of the necessary selections for all sensors. The Advanced settings screen allows for the adjustment of alarms. The Diagnostic screen displays the sensor readings and allows for manual calibration.

Some fields will be shown in gray when they are not relevant/active with the chosen setting. Detailed explanations of the individual fields will show up when the mouse is moved over the field. A setting can be changed by typing in a new value or by selecting in the drop down. After changing the value, it is stored to the sensor by clicking "Save to sensor". It remains in the sensor even when the power supply is disconnected.

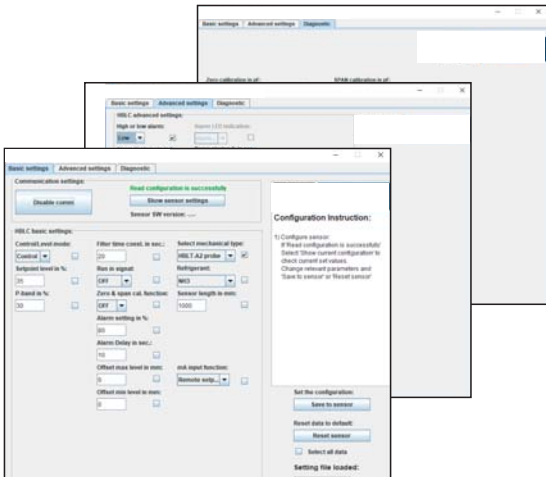

SETTING UP THE SENSOR: LEVEL / CONTROL

The sensor can operate in two different modes. The basic and advanced settings automatically adjust based on the identified mode.

- **Level:** A level input to a PLC, computer or other device that uses the analog signal (WLT)
- **Control:** A direct controller of a motorized valve based on the level. (WLT-C)

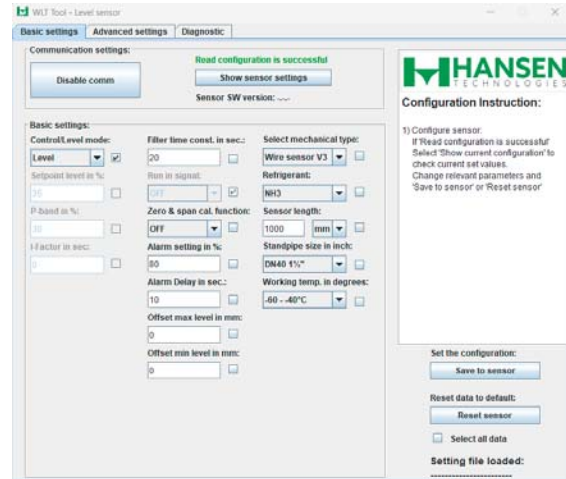

ADJUSTING SETTINGS

Settings can be modified through the drop-down and input boxes or by loading a new settings file. To create a new sensor file, do not connect to the sensor, open the Hansen Tool, and the steps are as follows:

Simulating tools → WLT tool → update desired fields

To save the file:

Advanced Settings → Save Settings file → Save to folder To load the file:

Connect programming cable to sensor → open Hansen Tool → Start scan for sensor → Advanced Settings → Load Settings file → Save to sensor → Basic Settings → Save to sensor

BASIC SETTINGS: LEVEL (WLT)

The Basic Settings screen contains the necessary selections for all sensors. When connected to the sensor, some settings are grayed out and cannot be changed. If changes are desired, see Adjusting Settings on page 8.

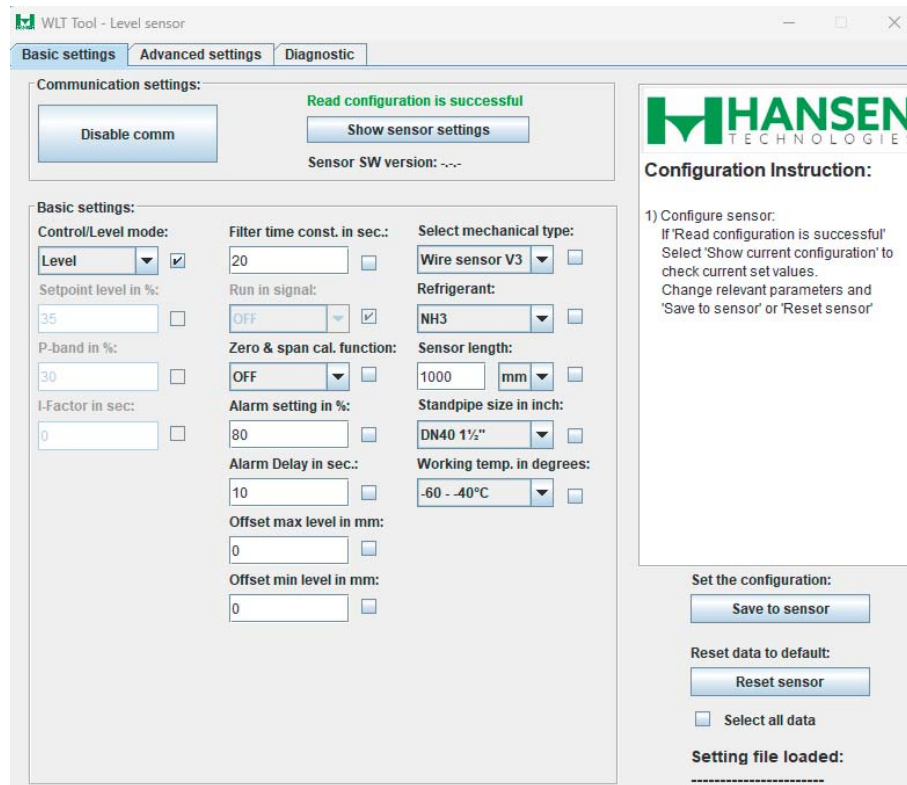

Filter time constant in sec.: Filter function: Filter time averages the output over a period (in seconds) and reduces fluctuations that can lead to unstable control. Recommended to leave at default value of "20" seconds.

Zero & span calibration function: Allows for manual calibration without a computer or WLT software tool. When "ON", the R button on the electric transmitter head can be used to set the 0% and 100% values. See page 11 for further details. Recommended to leave at default value of "OFF".

Alarm setting in %: The vessel level % set point off which the alarm LED will trigger.

Offset max/min level: Allows for the reduction of the measured maximum and/or minimum level. Based on the sensor design the typical max valve is 2.75" (70mm). Example (Max): 10ft (3058mm) high level column and full indication desired at 9.5ft (2987mm), then 71mm would go on the box.

Select mechanical type: All current Hansen probes are version "Wire Sensor V3".

Refrigerant: Indicates the refrigerant type. If medium is not in the list, select "Not Specified" and a manual calibration will have to be performed.

Sensor Length: The measurement length of the wire assembly. The value that was determined in step 3 on page 4.

Standpipe (Level Column) size in inch: The diameter of the level column.

Working Temperature in degrees: The refrigerant operating temperature range. Hover over the to drop-down to view Fahrenheit conversion.

ADVANCED SETTINGS (WLT)

When connected to the sensor, these settings are grayed out and cannot be changed. If changes are desired, see Adjusting Settings on page 8.

High or Low Alarm: High alarm triggers when the level gets above the Alarm setting % and Low alarm triggers when level gets below the setting. The Alarm setting % is found in the Basic Settings.

Alarm Hysteresis: The percentage difference from the Alarm setting % for when the alarm will turn off and reset. The default of 10% is adequate for most installations. Example: High Alarm setting % = 80%, Alarm Hysteresis % = 10; The high level alarm will trigger when the level reaches 80% and will stay in alarm until the level goes down below 70%.

Alarm relay function: Output status when an alarm occurs. Normally open will close upon an alarm and normally close will open when the alarm is triggered.

Output direction: Determines the milliamp value in accordance to the vessel level. Select LP or HP mode. LP: Empty vessel = 0% (4mA), Full vessel 100% (20mA) HP: Empty vessel = 0% (20mA), Full vessel 100% (4mA)

Set mA or digital 2 output: Allows for the selection of an analog output or just a digital alarm output based on the trigger. Most cases will be analog mode.

Digital 2 alarm in %: Additional alarm trigger set point

Digital Hysteresis in %: The percentage difference from the Digital 2 alarm % for when the alarm will turn off and reset.

Alarm LED indication: The LED on the electric transducer that illuminates when an alarm condition is met.

DIAGNOSTICS & SENSOR CALIBRATION VIA HANSEN TOOL

If the sensor is operating in one of the pre-defined refrigerants it is delivered factory calibrated and does not normally need further calibration. If the refrigerant is not in the list, perform the calibration below. Make sure the electronic transmitter is mounted on the mechanical wire in the column.

Zero calibration in pF: Displays the current 0% reference value.

SPAN calibration in pF: Displays the full range value from 0% to 100%.

Actual Measurement in pF: Displays the current measurement.

Zero calibration: Sets the 0% value during manual calibration. The vessel should be empty when this button is pressed.

Calibrate known level: Can be used to input a known value between 20% and 100% based on visual confirmation and set the actual value to the sensor when the button is pressed.

MANUAL CALIBRATION - NO SOFTWARE

If the sensor is operating in one of the pre-defined refrigerants it is delivered factory calibrated and does not normally need further calibration. If manual calibration is desired through the electronic transmitter, the function needs to be activated. The "Zero & span cal. Function" field found under basic settings has to be ON. The default is OFF.

Calibration for 0% or 100% can be carried out independent of each other per the following steps. The actions will call out the use of the "R" button found on the electronic transmitter.

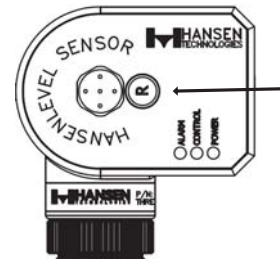

Instruction for 0% calibration:

- Connect the standard cable to power the sensor
- Empty the vessel.
- Press the "R" button for 5 seconds to activate calibration mode. The Yellow LED will be (ON) during the 5 second activation period and turns (OFF) when calibration mode is activated.
- Press "R" once to calibrate. The Yellow LED will flash once. Afterwards, the green LED flashes to confirm calibration.

Instruction for 100% calibration:

- Connect the standard cable to power the sensor.
- Fill the vessel to 100%.
- Press the "R" button for 5 seconds to activate calibration mode. The Yellow LED will be (ON) during the 5 second activation period and turns off (OFF) when calibration mode is activated.
- Press the "R" button twice. The Yellow LED will flash twice. Afterwards, the green LED flashes to confirm calibration.

LEVEL COLUMN DIMENSIONS

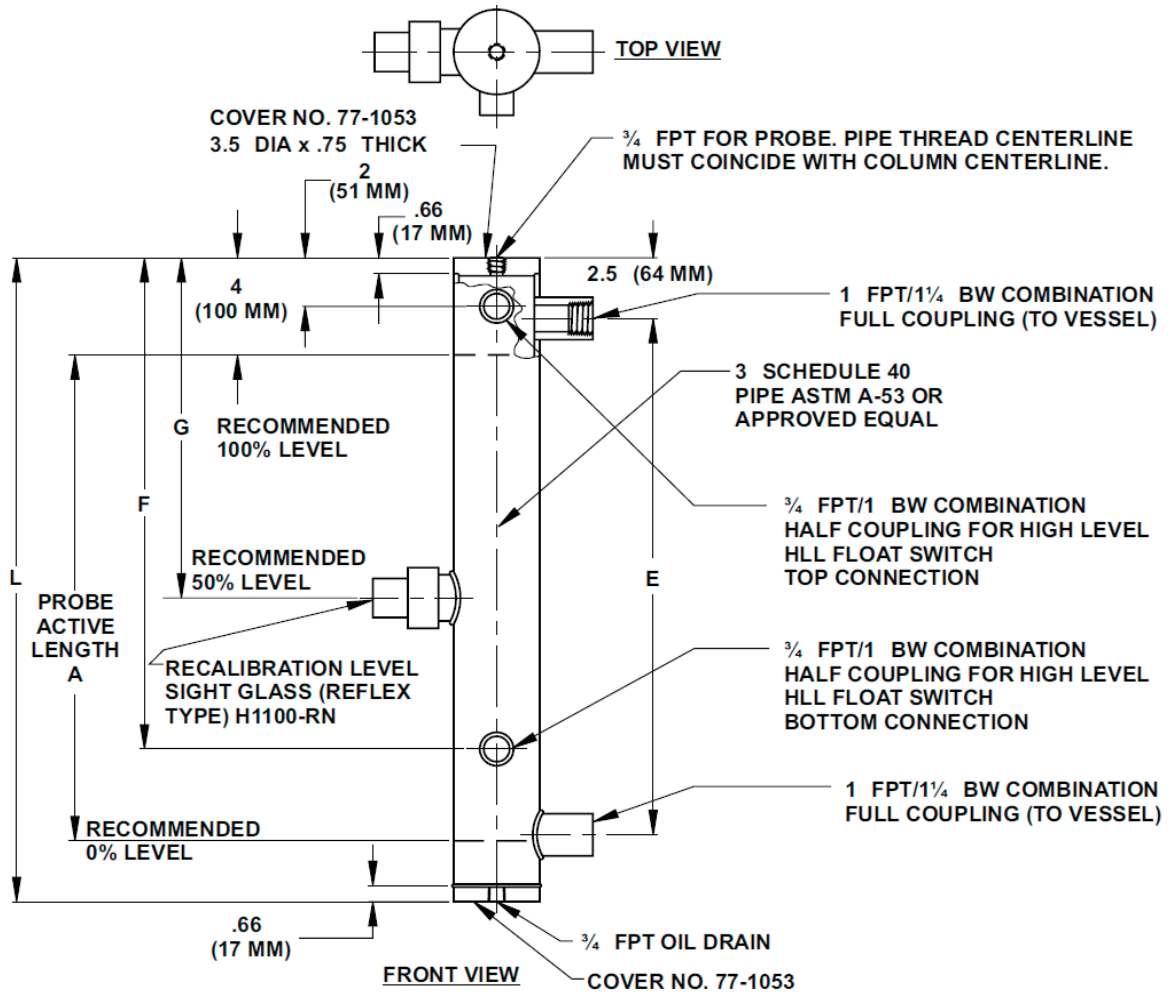

COMPLETE LEVEL COLUMN UP TO 120 (3050 MM) OR PARTS ARE AVAILABLE FROM HANSEN TECHNOLOGIES. PLUGS ARE SUPPLIED FOR THE OIL DRAIN AND FLOAT SWITCH CONNECTIONS.

CATALOG NUMBER	SENSOR ACTIVE LENGTH A	EQUALIZER LEGS E	FLOAT SWITCH LEG F	SIGHT GLASS LOCATION G	COLUMN OVERALL HEIGHT L
LC.02	20" 510 mm	21.25" 540 mm	18.50" 470 mm	14.00" 356 mm	26.50" 673 mm
LC.03	30" 760 mm	31.25" 794 mm	31.13" 791 mm	19.00" 483 mm	36.50" 927 mm
LC.04	40" 1015 mm	41.25" 1048 mm	36.13" 918 mm	24.00" 610 mm	46.50" 1181 mm
LC.06	60" 1525 mm	61.25" 1556 mm	46.13" 1172 mm	34.00" 864 mm	67.25" 1708 mm
LC.08	80" 2030 mm	81.25" 2064 mm	56.13" 1426 mm	44.00" 1118 mm	87.25" 2216 mm
LC.10	100" 2540 mm	101.25" 2572 mm	66.13" 1680 mm	54.00" 1372 mm	107.25" 2724 mm
LC.12	120" 3050 mm	121.25" 3080 mm	76.13" 1934 mm	64.00" 1626 mm	127.25" 3232 mm
(For Field Construction)	144" 3660 mm	145.25" 3689 mm	88.13" 2239 mm	76.00" 1930 mm	151.25" 3842 mm
(For Field Construction)	168" 4270 mm	169.25" 4299 mm	100.13" 2543 mm	88.00" 2235 mm	175.25" 4451 mm

SENSOR DIMENSIONS

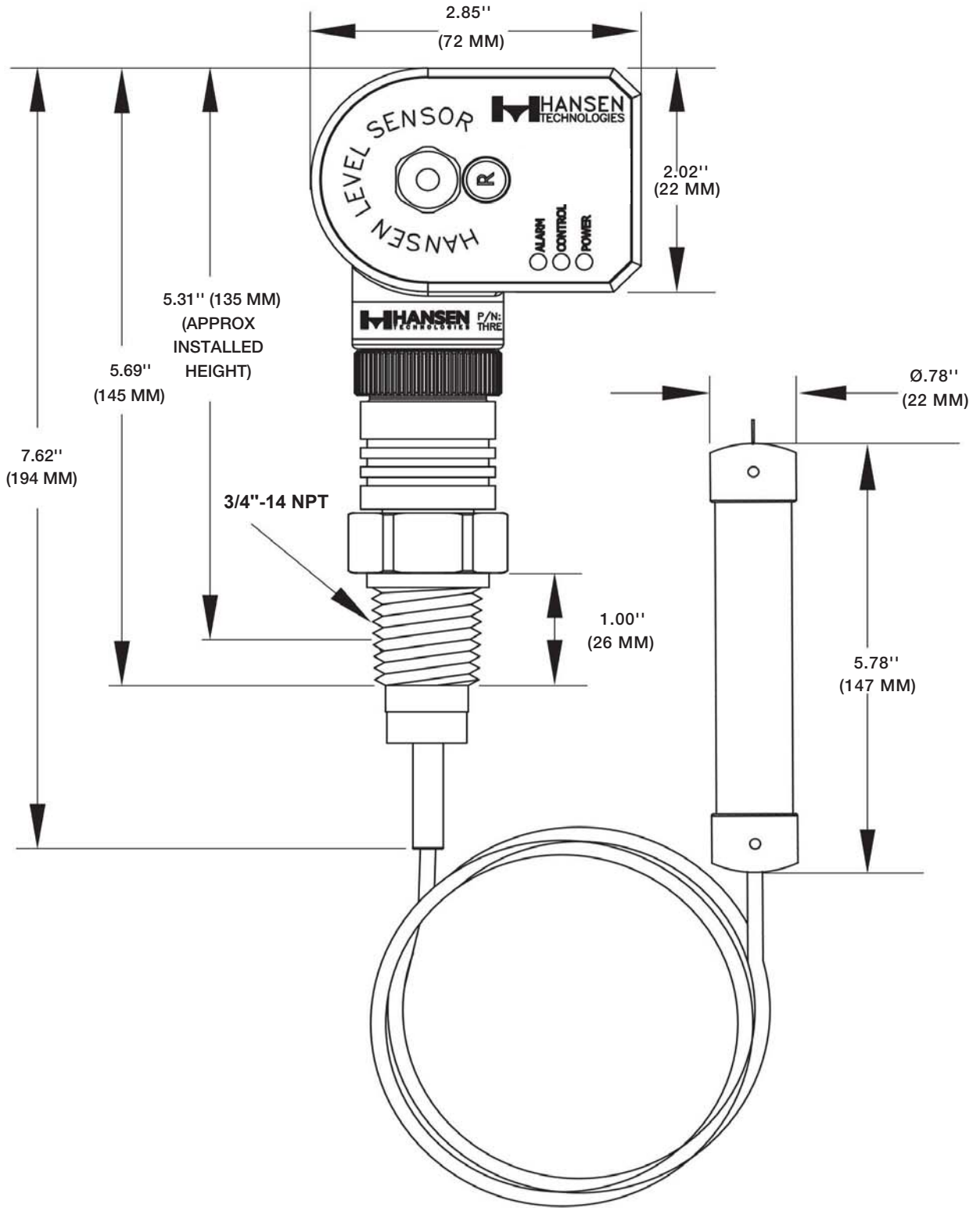

LED INDICATION

LED Signal	ON/OFF/Frequency	Functionality
Green	ON	Supply Voltage connected
	Flash	Run-in start signal / in operation.
	OFF	No supply voltage
Yellow	ON	Activation of valve control and during calibration
	OFF	Valve control not active
Red	ON	Alarm: high or low level, depending upon the setup.
	Flash slow	No contact to sensor or sensor shorted
	Flash fast	USB cable connected and communication active
	OFF	No alarm
Yellow + Red	Flash	Insufficient power supply
All	Flash	USB cable connected and communication active
	OFF	No alarm

- Green LED indicates 24 V DC supply; it flashes during operation. If "run-in" is not used, this function must be deactivated in the tool.
- Yellow LED indicates control. The flashing sequence indicates if the valve is closing or opening.
- Red LED indicates high- or low-level alarm, depending upon the setup.



LED Indication located at bottom of transmitter housing

TROUBLESHOOTING

PROBLEM	CAUSE	ACTION
No LED is on / not operating.	No supply to the sensor or defective cable/plug	Check and find faults in the power supply, or replace the supply cable.
Yellow and red LED flashing.	Power supply is not sufficient.	Install proper power supply.
No contact activation	There may be debris between the electronic housing and the mechanical housing.	Separate the two parts and clean the spring tip. Remember to apply silicone grease to the spring tip so as to avoid problems with moisture
Delay in sensor activation	May be caused by gas and bubbles in the system.	Check if the sensor is placed optimally so that gas is avoided.
The sensor is not reading doesn't match the sight glasses	Oil has accumulated in the level column which cannot escape.	Drain the level column of oil and if necessary, clean the oil from the wire.
There is no alignment between the output signal and the level in the level indicator.	The sensor was not properly setup or incorrectly calibrated.	Review sensor setup via software tool. If necessary, perform calibration.

*Fault detection and/or changing the electronic function can be carried out without releasing pressure from the system or disassembling the mechanical part of the sensor.

VARI-LEVEL® ADJUSTABLE LEVEL CONTROL

The system consists of a control unit and a sensor which is inserted in a level column. Control unit models are available with up to five individual level set point relays. Level set points and differentials can be easily set up, and then simply changed by moving knobs when necessary. A built-in level simulator enables the operator to easily check proper operation of control valves, pumps, and alarms at the various set points.

HLL FLOAT SWITCH

The Hansen Refrigerant liquid level float switches (HLL Series) are used to electrically indicate or control a liquid level by opening or closing a SPDT switch. Their simple, reliable design provides a long life performance for almost any application.

WARRANTY

Hansen electronics are guaranteed against defective materials or workmanship for 90 days F.O.B. our factory. All other components are guaranteed for one year F.O.B. our factory. No consequential damages or field labor is included.

To Order: Specify catalog number, refrigerant, and if a level column is desired. Where possible describe and sketch the application.

MODEL ORDER INFORMATION

Model Number	Description
WLT	2-wire Level Transducer Sensor

OPTIONAL EQUIPMENT & SPARE PARTS

Model Number	Description
WLT-EL*	WLT Replacement 2 Wire Transmitter Kit
WLT-PLUMB*	WLT Counterweight Kit
WLT-WIRE*	Mechanical Base with Wire Element Kit
WLT-M12	M12 Field Cable - 16ft (5m)
WLT-M12 EXTENSION	M12 Extension Cable - 33ft (10m)
WLT-USB*	USB/M12 Programming Cable
LPE	LP Emulator Kit
RDR	Remote Digital Display
PSU2	Power Supply: 100-240VAC:24VDC; 15W

NOTE: * indicates included in WLT

CAUTION

Hansen level wire probes have been designed specifically for refrigeration systems. These instructions and related safety precautions must be completely read and understood before selecting, using, or servicing these probes. Only knowledgeable, trained refrigeration technicians should install, operate, or service these probes. Stated temperature and pressure limits should not be exceeded and all electronics should be protected from moisture. Do not remove probes from level columns or vessels unless the system has been evacuated to zero pressure. See also Safety Precautions in the current List Price Bulletin and the Safety Precaution Sheet supplied with the product. Escaping refrigerant can cause injury, especially to the eyes and lungs.

WARNING: As with all electronic and mechanical components, there is a limited life expectancy. An expected life of seven to ten years is typical. However, this should be understood as only a suggested replacement time period. Actual performance and physical condition of the electronics due to ambient conditions, quality of electrical current or voltage, etc., may necessitate a different replacement schedule. Regardless, probes should be inspected at least once a year to ensure safe and continuous service.



Hansen Technologies Corporation
681 Commerce St.

Burr Ridge, Illinois 60527 USA

Tel: 630.325.1565 Fax: 630.325.1572 Toll: 866.4HANSEN

Email: sales@hantech.com Web: www.hantech.com

USA · Asia · Europe · India · Latin America · Middle East

© 2023 Hansen Technologies Corporation